

PlasmalabSystem100

Modular Cluster System

Works Order No.: 94-721002

Customer: University of Utah

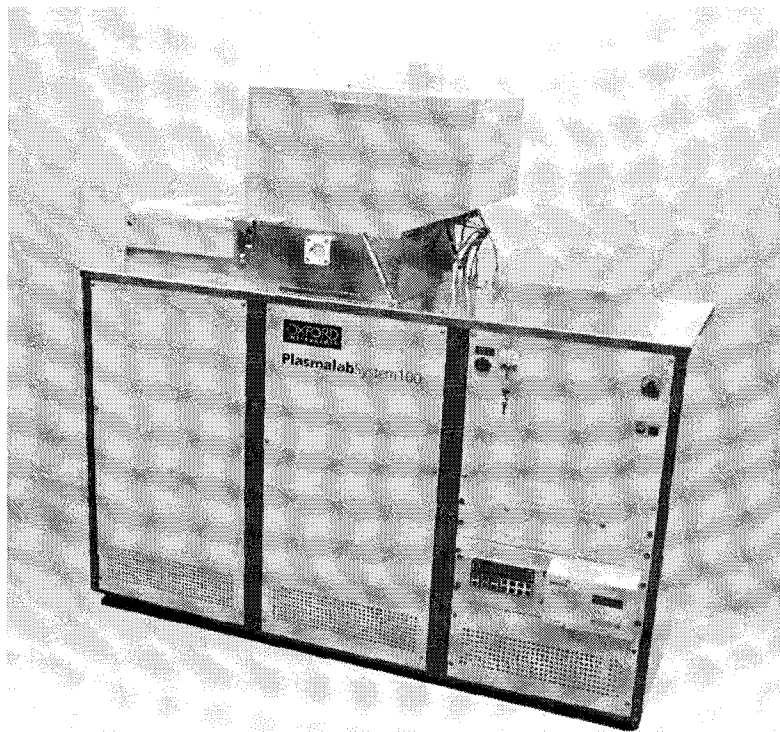

Typical **PlasmalabSystem100** (ICP 180)

WARNING

THIS SYSTEM INCORPORATES POTENTIALLY DANGEROUS COMPONENTS, WHICH CAN EXPOSE PERSONNEL TO HAZARDS RESULTING IN DEATH OR SERIOUS INJURY.

BEFORE ATTEMPTING TO INSTALL, POWER UP OR OPERATE THIS SYSTEM, ENSURE YOU HAVE READ AND UNDERSTOOD THE ENCLOSED SYSTEM MANUAL, ESPECIALLY SECTION 1 (HEALTH AND SAFETY).

R1 OPT
L OPT

System 100

Plasmalab System 100

Modular Cluster System

Works Order No.: 94-721002

Customer: University of Utah

Volume 1: Operation and Maintenance Manual

This manual, Volume 1, is one of a series for the machine as follows:

Volume 1	Operation and Maintenance Manual
Volume 2	System Drawings
Volume 3	OEM Manuals

Notes:

1. Please regard this manual as part of the system.
2. Ensure that any amendment received is incorporated in the text.

Oxford Instruments Plasma Technology
Yatton, Bristol, BS49 4AP
Tel: +44 1934 837000
Fax: +44 1934 837001

Issue 1: March 2006



Contents

Title and inside front cover pages

Contents List.....	(iii)
Preface	(iv)
Customer Support Facilities.....	(iv)
Quality Control Forms	(v)
Goods Return Form QCF60	
Certificate of Pre-Acceptance and Certificate of Acceptance QCF 61	
System Readiness Form QCF 89	

1. Health and Safety	1-1
-----------------------------------	------------

2. Services (ICP 180).....	2-1
-----------------------------------	------------

3. Description.....	3-1
----------------------------	------------

4. Installation.....	4-1
-----------------------------	------------

5. Operating Instructions	5-1
--	------------

6. Maintenance	6-1
-----------------------------	------------

7. Process Guide and Glossary	8-1
--	------------

8. Uninstallation and disposal	9-1
---	------------

Appendix A Measurement of radio frequency and microwave emissions

Appendix B Operation and maintenance of turbomolecular pumps

Appendix C Concessions

Appendix E PC hard drive restore information

Appendix IDS Installation Data Sheets (ICP 180)

Appendix R Rotameter data

Appendix S Services Specifications for Plasmalab and Ionfab Systems

ICP 180 Inductively Coupled Plasma Source Equipment Manual

OIPT Automatch Unit Equipment Manual

Plasmalab System 100 Illustrated Parts Catalogue (ICP 180)

System Restore DVD (in HDD Restore Kit) and System Software CD

Preface

This manual is the **OPERATION and MAINTENANCE MANUAL**. It provides all the information necessary for the operation and routine maintenance of the system. Certain components within the system are supplied by other manufacturers. These components have their separate manuals which are included, and should be referred to for detailed operation, maintenance and repair information.

	<p>WARNING</p> <p>SERVICE BY QUALIFIED STAFF ONLY Refer to manual</p>	<p>Where this label is displayed (black text on a yellow background), read the relevant manual before proceeding to operate or maintain the labelled equipment.</p>
---	--	--

Customer Support Facilities

Oxford Instruments Plasma Technology has global Customer Support Facilities to provide a co-ordinated response to customer's queries. All queries are recorded on our Support Database and dealt with as quickly as possible. If we are not able to answer the query immediately, we will contact you as soon as possible.

Before contacting a Customer Support Facility, please ensure that you have referred to the appropriate section of your system manual, OEM manuals and electrical drawings.

Please direct all queries through your nearest support facility (see below) and have the following details available.

System Type, e.g. **PlasmalabSystem100** etc.

Works Order No. – This can be found on the front cover of your system manual.

Contact Information – Your name, Company and how we can contact you.

Details of your query – nature of the problem, part numbers of spares required, etc.

You can contact us via any of the following:

China

Beijing

Tel: +86 106518 8160

Email: pt.support@oichina.cn

Shanghai

Tel: +8621 6360 8530

Email: pt.support@oichina.cn

Germany

Tel: +49 6122 937 161

Email: info@oxford.de

Japan

Tel: +81 3 5245 3591

Email: oikkpt@oxinst.co.jp

Singapore

Tel: +65 6337 6848

Email: pt.support@oxford-instruments.com.sg

Taiwan

Tel: +886 3 5788696

Email: pt.support@oxford-instruments.com.tw

UK

Customer Support Hotline: +44(0) 1934 837070

(0800 – 2000 UK local time)

Fax: +44(0) 1934 837071

Email: pt.support@oxinst.co.uk

USA

Concord, MA

Tel: +1 978 9933 ext. 444

Toll Free: +1 800 447 4717 ext. 444

Fax: +1 978 369 8287

Email: support.pt@ma.oxinst.com

Quality Control forms

The following Quality Control Forms (QCF) are attached:

Goods Return Form QCF 60 – To be completed and attached to the outside of the package of any returned parts.

Certificate of Pre-Acceptance and Certificate of Acceptance QCF 61 – To be completed and returned if the customer is absent from acceptance.

System Readiness Form QCF 89 – To be completed and returned prior to the commissioning visit.



GOODS RETURN FORM

Returns No :

- This form must be completed and a copy sent to Oxford Plasma Technology Service Department by fax or mail before return of any goods to the factory. (Fax No : + 44 (0) 1934 837071)
- If return to the factory is approved a Returns Authorisation Number will be issued. This should be written in the box provided on this form and the completed form returned with the goods as part of the shipping documentation. ***It must be possible to read this form without opening the packaging containing the goods, therefore the form should not be enclosed within the packaging but affixed to the container.***
- Once the Returns Authorisation Number is issued goods should be returned within one month. OIPT reserve the right to invoice the full value of parts if not returned.
- All sections below must be completed. If any section does not apply, mark that section "not applicable". If the information requested is not known, mark that section "not known".
- ***Any goods returned to the factory without a copy of this form carrying a Returns Authorisation Number will be considered hazardous and may be disposed of at the sender's expense. Mark the returns number on all packages and supporting shipping documentation.***

Equipment description.	Serial number or identifying marking	
	Original OIPT order No :	Date of order :
Reason for return of part/s.	Description of fault/s.	
Chemical names of all materials which have come into contact with the goods.	Precautions which must be taken when handling these materials.	
Nature of hazard(s) presented by contact with these materials.	Action to be taken in the event of human contact or spillage of these materials.	
Details of any decontamination carried out prior to shipping	Levels of residual substances left in or on the returned goods.	
Name and address of person to be contacted in case of query.	Tel No :	Ext :
	Fax No :	

Declaration

Please strike through the section a) or b) which does not apply and sign the declaration.

- a) I hereby confirm that the equipment detailed above has not come into contact with any hazardous substance and has been drained of any lubricant.
- b) I hereby confirm that the only hazardous materials to which the equipment detailed above has been exposed are listed above and that the following precautions have been taken.
 1. The equipment has been drained of any lubricant
 2. All ports have been sealed and the equipment has been securely packed and labelled in accordance with Oxford Instruments Plasma Technology recommendations (available on request)
 3. The carrier has been informed of the nature of the consignment.

Signed..... Date.....

Name..... Position.....



Oxford Instruments Plasma Technology
North End, Yatton
Bristol, BS49 4AP
England.
Telephone : +44 (0) 1934 837000
Fax: +44 (0) 1934 837001
E mail: plasma.technology@oxinst.co.uk

CERTIFICATE OF PRE-ACCEPTANCE

This form is to be completed in accordance with the guidelines stated in QCF 61a.

Form with fields for Customer, Project number, Equipment serial number/s, and Brief description of the system. Includes a table for listing items to be actioned.

Witnessed by: Oxford Instruments Plasma Technology representative
Signature: Date: / / 0

Accepted by: Representative of the end user.
Signature: Date: / / 0

OIPT circulation:
Service Manager
Design Manager



Oxford Instruments Plasma Technology
North End, Yatton
Bristol, BS49 4AP
England.

Telephone : +44 (0) 1934 837000
Fax: +44 (0) 1934 837001
E mail: plasma.technology@oxinst.co.uk

CERTIFICATE OF ACCEPTANCE

Customer: Project number: Equipment serial number/s:	Brief description of the system: Pre-acceptance form completed at OIPT ? Yes / No
--	--

The equipment supplied has been examined and tested as an assembled system in my presence, and has given satisfactory results where shown. (Tick as appropriate)

Operational **Process**

I am satisfied with the results that this system has produced and I accept that the technical specifications have been achieved.

Comments:-

Accepted by: Representative of the end user.

Signature: _____ Date: / / 0

Please ask our representative for a copy of our Customer feedback form, in order that you may record your opinions of the service given by Oxford Plasma Technology Ltd.

Witnessed by: Oxford Instruments Plasma Technology representative

Signature: _____ Date: / / 0

OIPT circulation:
Service Manager
Design Manager



Please return the completed form to
your nearest Oxford Instruments
Support Office, detailed below:

USA & Canada

Oxford Instruments America Inc

Plasma Technology Support Manager
130A Baker Avenue Extension
Concord
MA 01742
Tel: (800) 447 4717
Fax: (978) 369 8287
Email: CSG@ma.oxinst.com

DE, NE, B, SE, FI,DK

Oxford Instruments GmbH

Plasma Technology
Postfach 4509
65035 Wiesbaden
Germany
Tel: +49 6122 937161
Fax: +49 6122 937175
Email: Plasma@oxford.de

Eastern Territories

Oxford Instruments Pte. Ltd

Raymond Wong
371 Beach Road
#02-07 Keypoint
Singapore 199597
Tel: +65 6337 6848
Fax: +65 6337 6286
Email: Raymond.Wong@oxford-instruments.com.sg

U.K. and all Other Territories

Oxford Instruments Plasma

Technology
Global Support Manager
North End
Yatton, Nr Bristol
BS49 4AP. U.K.
Tel: +44 1934 837070
Fax: +44 1934 837071
Email: Support.PT@oxinst.co.uk



QCF 89 Issue 6

Please tick appropriate box		YES	NO	Detail
15. Have the rotary pump exhaust lines been connected to an exhaust extraction system that meets all local safety standards?				
16. If the system is fitted with a cryo pump, which is used for toxic gasses, has an action plan been discussed and implemented for connection of the pump outlet connector?				
17. Has the rotary pump purge been connected to the pumps and nitrogen supply?				
18. Have the rotary pumps been filled with oil of the correct type for the pump in use?				
20. Is the gas pod extraction connected with a minimum flow rate of 1m ³ /hour (6 line gas pod) or 3 m ³ /hour (12 line gas pod). Does the extraction system meet all local safety regulations?				
21. Do you believe that that demonstration of process has been included in the purchase of your tool?				
21.a. Please state, which processes require to be demonstrated.				
21.b. Are the required samples and measurement equipment available for the process work to follow on from hardware acceptance?				
Name :		Position Within Company:		
Signature:		Date: / / 0		
Preferred Date for Commissioning Commencement:		/ / 0		



QCF 89 Issue 6

Please tick appropriate box	YES	NO	Detail									
			Phase 1 to Neutral		Phase 2 to Neutral		Phase 3 to Neutral					
7. Has AC power been connected to the system? Measure the voltages between each phase and neutral.			Phase 1 to Neutral		Phase 2 to Neutral		Phase 3 to Neutral					
8. Has compressed air been connected to the system? Inlet pressure must be 6 Bar (90PSI). Note Pressure.			Compressed Air Inlet Pressure									
9. Has cooling water been connected to the system? Differential pressure between inlet and outlet must be 3 - 4 Bar (45 - 60PSI). Water supply should be connected to each inlet/outlet on the system in parallel and not series. Note Inlet and Outlet Pressure.			Inlet Water Pressure				Outlet Water Pressure					
10. Has N2 vent been connected to the system? Inlet must be able to maintain a pressure of 3 Bar (45psig). Note Pressure.			Vent Nitrogen Inlet Pressure									
11. Has N2 purge been connected to the system? Inlet must be able to maintain a pressure of 3 Bar (45psig). Note Pressure.			Purge Nitrogen Inlet Pressure									
12. If the system is configured with cryogenic cooling, is an LN2 Dewar, filled with LN2 available? Is the Dewar connected to the system via 3/8" Swagelock connections and is the pipe work adequately insulated to prevent a safety hazard?			Is the pipe work adequately insulated to prevent a safety hazard?									
13. Have all of the gas pod connections been made to the appropriate gas supply or system connection. Have they been leak checked?												
<p>14. All process gasses should be available for the system commissioning. Please verify that each gas, as it is laid out in the gas pod is connected, available for process and that the gas line has been leak checked.</p> <p>Please record the leak rate for each gas line. If there is no line fitted please enter N/A.</p> <p>Process gas inlet pressure should be set at 3 Bar (45psig). Minimum acceptable inlet pressure: 2 Bar (30psig). Maximum acceptable inlet pressure: 5 Bar (75psig).</p> <p>If the gas line is to be used for BCl₃, SiCl₄ or TEOS, has the gas line been wrapped with trace heater wire and insulated? Failure to do so could result in condensation of the gas, within the line during processing.</p>			Name of Gas	Inlet Pressure	Heated ?	Leak Rate		Name of Gas	Inlet Pressure	Heated ?	Leak Rate	
			Gas 1					Gas 7				
			Gas 2					Gas 8				
			Gas 3					Gas 9				
			Gas 4					Gas 10				
			Gas 5					Gas 11				
			Gas 6					Gas 12				



SYSTEM READINESS FORM

This form is provided in order for us to record the level of work that you have conducted, to support the installation of your new Oxford Instruments system. The system should be installed, within the parameters listed below and the form returned to your supporting Oxford Instruments office. Returning this form signifies that you have completed the installation of the system, in accordance with the Services and Specifications data sheet and that the installation conforms with all of the requirements listed within. Should you not have a copy of the afore-mentioned "Services & Specifications" data sheet, you should contact your supporting Oxford Instruments office immediately and obtain a copy.

Should this form be received, an engineer dispatched to start commissioning and any of the facilities requirements not be met, Oxford Instruments reserves the right to terminate that commissioning visit and charge the customer for a return visit, once the facilities have been fully completed.

Company Name :		Company Contact Name:	
System Serial Number :		System Type:	
Please tick appropriate box		YES	NO
1. Has the system been sited ? Attach site plan if available.			
2. Has the system been installed in a clean room ?			
3. Are there any special requirements for gaining access into the clean room ? ie. clearance, training, citizenship etc.. If so please list below.			
4. Have pumps been sited and the cables between each pump and system power box been connected?			
5. Has the gas pod been sited, connected to the system and connected in to the appropriate gas delivery and exhaust extraction systems, in accordance with local safety regulations?			
6. If the system has a heater chiller, has this been sited, connected to the lower electrode cooling circuit and filled with Hexid A40?			

1. Health and Safety

A l'attention des clients de langue française

Le document hygiène et sécurité est disponible en français. Vous devez vous assurer que cette version est présente dans ce manuel. Si elle est manquante contactez votre représentant Oxford Instruments Plasma Technology.

Für deutschsprachige Kunden

besteht dieses Kapitel "Health and Safety" unter dem Titel "Sicherheit und Unfallverhütung" auch in deutscher Fassung, die in diesem Handbuch enthalten sein sollte. Falls diese fehlt, fordern Sie bitte ein Exemplar bei Oxford Instruments Plasma Technology an.

この安全概要 (Health and Safety) に関しましては、日本語版もございますのでマニュアルに含まれてない場合はお問い合わせ下さい。

Contents

1 Health and Safety	1-1
1.1 Introduction.....	1-2
1.1.1 Warnings and Cautions.....	1-2
1.2 Hazard Categories.....	1-3
1.3 Specific Hazards.....	1-4
1.3.1 Electrical.....	1-4
1.3.2 Electromagnetic Radiation.....	1-5
1.3.3 Light.....	1-6
1.3.4 High Temperature.....	1-7
1.3.5 Low Temperature.....	1-7
1.3.6 Gases.....	1-8
1.3.7 Materials.....	1-10
1.3.8 Process Chemicals.....	1-12
1.3.9 Vacuum.....	1-12
1.3.10 Compressed air.....	1-13
1.3.11 Mechanical.....	1-13
1.3.12 General.....	1-14
1.4 Warning and advisory labels.....	1-16

1.1 Introduction

This section must be read and understood before the system is approached or operated and before any maintenance work is carried out.

It is a requirement that procedures and practices taught in Oxford Instruments Plasma Technology training courses are followed.

If the equipment is used in a manner not specified by Oxford Instruments Plasma Technology, the protection provided by the equipment may be impaired.

Please read this section carefully, and note that certain aspects of the system can produce more than one hazard (e.g. process gases can be a fire hazard and a toxic hazard).

Some safety features are fitted to guard against more than one hazard. In particular, note that some view ports must guard against UV light emission (sub-section 1.3.3, page 1-6), RF energy emission (sub-section 1.3.2, page 1-5) and must be fitted with implosion guards.

Note that this document is standardised and may contain warnings, which are not relevant to your particular system.

1.1.1 Warnings and Cautions

Throughout this manual **WARNINGS** are inserted in the text to draw the reader's attention to hazards. Failure to comply with a **WARNING** could result in death or serious injury. A typical warning is shown below:

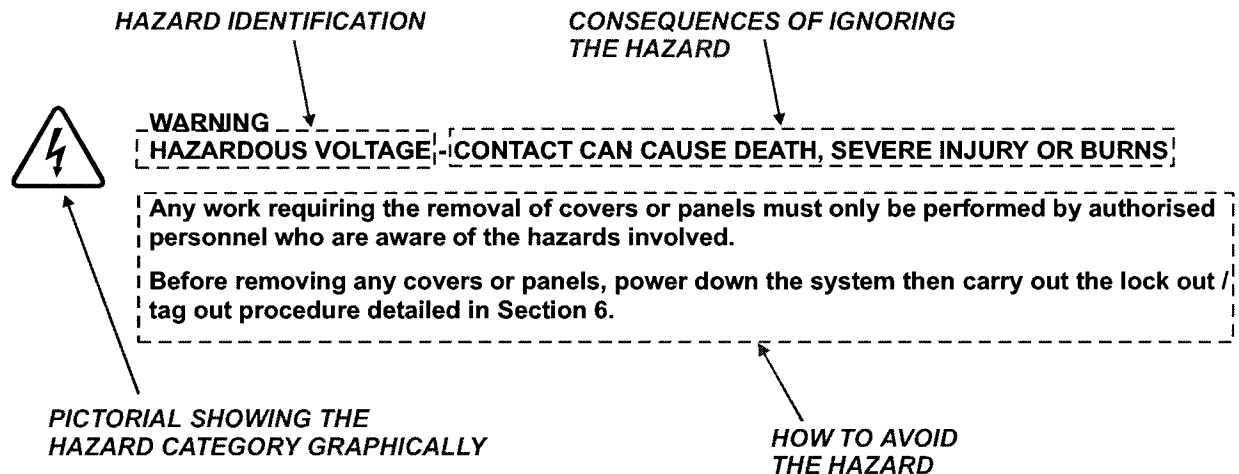

Throughout this manual **CAUTIONS** are inserted in the text to draw the reader's attention to situations and procedures, which could cause damage to the equipment. A typical **CAUTION** is shown below:

	<p>CAUTION</p> <p>Upper electrodes can become contaminated from finger marks etc.</p> <p>When working on the upper electrodes, ensure that powder-free cleanroom gloves are worn.</p>
---	--

1.2 Hazard Categories

Hazards and associated warnings relevant to Health and Safety which appear in the text of this manual and in this section will fall into the following categories:

- a) **Electrical**
(sub-section 1.3.1,
page 1-4) The system carries voltages high enough to cause death or serious injury. Even when the electrical power supply is isolated, electrical energy at dangerous levels is stored by capacitors.
- b) **Electromagnetic Radiation**
(sub-section 1.3.2,
page 1-5) Parts of the system produce electromagnetic radiation from audio frequencies to 2.45 GHz. This radiation can have a field strength strong enough to cause death or injury if not properly shielded.
- c) **Light**
(sub-section 1.3.3,
page 1-6) Ultra Violet (UV) or Laser light may be emitted in some systems. These can cause permanent damage to the eyes or blindness if not protected by the relevant shields or filters.
- d) **High Temperature**
(sub-section 1.3.4,
page 1-7) Some components run at a temperature high enough to cause severe burns.
- e) **Low Temperature**
(sub-section 1.3.5,
page 1-7) Components and gases at very low temperatures can cause severe 'burns' if allowed to contact the skin.
- f) **Gases**
(sub-section 1.3.6,
page 1-8) Some process gases and cleaning fluid vapour may be toxic, corrosive, carcinogenic or flammable. They may also cause asphyxiation through oxygen deprivation. Gases under pressure can, if applied to the body, enter it and cause death or serious injury.
- g) **Materials**
(sub-section 1.3.7,
page 1-10) Some materials used in the system can become toxic during use. If this happens, then great care must be taken during maintenance to prevent death or serious injury.
- h) **Process Chemicals**
(sub-section 1.3.8,
page 1-12) Some etching and deposition compounds are toxic during use, and can leave toxic residues in the system.
- i) **Vacuum**
(sub-section 1.3.9,
page 1-12) Chambers or other components under partial vacuum represent stored energy, which can cause injury if released carelessly.
- j) **Compressed Air**
(sub-section 1.3.10,
page 1-13) Compressed air can enter the body through the skin and cause serious injury. Pneumatically operated system components can be actuated suddenly, even when the system is not operating, causing serious injury.
- k) **Mechanical**
(sub-section 1.3.11,
page 1-13) Injury can be caused by heavy components, sprung components, deposition layers under stress, embrittled wire and machinery in motion.
- l) **General**
(sub-section 1.3.12,
page 1-14) Various procedures must be studied and followed. These include procedures specific to the system in question and also local and national Health and Safety standards.

1.3 Specific Hazards

1.3.1 Electrical

**WARNING****HAZARDOUS VOLTAGE - CONTACT CAN CAUSE DEATH, SEVERE INJURY OR BURNS**

Any work requiring the removal of covers or panels must only be performed by authorised personnel who are aware of the hazards involved.

Before removing any covers or panels, power down the system then carry out the lock out / tag out procedure detailed in Section 6.

- 1.3.1.1 Parts of the system carry high voltages, which are capable of causing injury or death. Take great care when carrying out maintenance tasks.
- 1.3.1.2 Do not operate the system if any of the doors, panels or covers are removed. Parts of the system may still be 'live' even when shut down by a switch, blown fuse or control function. Note that the system POWER OFF button does not isolate the main distribution panel.
- 1.3.1.3 Ensure that all system units are connected to electrical earth (ground). For details of the required electrical installation, refer to the 'Services Specifications for **Plasmalab** and **Ionfab** systems' document which is included at the rear of this manual's binder.
- 1.3.1.4 During troubleshooting and calibration, the power supplies may need to be connected with live components exposed. **This work must only be carried out by skilled personnel who are aware of the hazards involved.**
- 1.3.1.5 Ensure that all safety interlocks are tested before the system is used for the first time and at scheduled intervals thereafter. **These tests must be carried out by suitably qualified personnel.**
- 1.3.1.6 Inspect the system regularly for damaged components, e.g. cables, connectors or switches. Any components found damaged must be replaced before continuing to operate the system. Refer to the instructions in the maintenance section of this manual for details of any particular tests of the cables that may be required.
- 1.3.1.7 If any water leaks are detected, immediately switch the system off at the main incoming circuit breaker.
- 1.3.1.8 No servicing is to be carried out unless all personnel involved fully understand the danger of stored electrical energy. Refer to the lock out / tag out procedure detailed in Section 6.

1.3.2 Electromagnetic Radiation



WARNING
HAZARDOUS RF AND MICROWAVE EMISSIONS - EXPOSURE CAN CAUSE SEVERE INJURY OR BURNS

Before operating the System On button, ensure that all RF and / or microwave shielding is correctly fitted and that all connectors and flanges are in place.

- 1.3.2.1 Parts of the system produce electromagnetic radiation from audio frequencies to 2.45 GHz. At all frequencies within this range there is a field strength level at which radiation can cause injury. Oxford Instruments Plasma Technology specifies limits for the Electric and Magnetic field strengths within the environment of the system.

The system must be tested to ensure that radiation is within these limits, using suitably calibrated equipment. The tests must be carried out after maintenance involving RF shielding components, and routinely every three months. Refer to the instructions in the maintenance section of this manual.

- 1.3.2.2 Ensure that all waveguide components, flanges and cables are correctly fitted, secure and undamaged.

View ports on Plasmalab systems and on certain Ionfab systems are fitted with a metal grid for shielding RF radiation. Replace this item only with the correct part, and ensure that the ports are correctly reassembled.

If a metal grid is not fitted and there is any doubt about whether one should be fitted, you must check with Oxford Instruments Plasma Technology before proceeding. If the view port has been disassembled then tests must be carried out as described in sub-section 1.3.2.1 above.

- 1.3.2.3 Operating the equipment with any panels removed increases the risk of RF burns. Maintenance procedures, which require this, must only be performed by skilled persons who have access to a suitable field strength meter.

- 1.3.2.4 Removing panels or modifying the equipment may increase the radio interference emitted by the equipment above permitted levels. This may cause nearby equipment to operate unexpectedly.

- 1.3.2.5 If portable transmitting equipment, e.g. radio, cellular phone, etc., is used within two metres of the equipment, the equipment could operate unexpectedly. Removing panels or modifying the equipment may increase this risk.

1.3.3 Light



WARNING
LASER RADIATION - EXPOSURE CAN CAUSE SEVERE EYE DAMAGE OR BURNS

Before operating the system, ensure that all covers are fitted correctly.

Ensure that for laser equipment, the manufacturer's instructions have been read and fully understood.

- 1.3.3.1 Laser equipment when handled incorrectly or in a damaged condition can seriously damage eyesight. Read and follow the manufacturer's instructions carefully. Ensure that all covers supplied by Oxford Instruments Plasma Technology or by the manufacturer are correctly fitted before the equipment is powered up.



WARNING
ULTRA VIOLET RADIATION - EXPOSURE CAN CAUSE SEVERE EYE DAMAGE OR BURNS

Ensure that all view ports are assembled correctly, and that any replacement filters are of the correct specification.

- 1.3.3.2 View ports on Plasmalab systems are fitted with a clear plastic UV filter (Perspex -VE-clear-003). Replace this item only with the correct part, and ensure that the ports are correctly reassembled.

If a plastic filter is not fitted, or if there is any doubt about the type of filter that is fitted, you must check with Oxford Instruments Plasma Technology before proceeding.

- 1.3.3.3 The customer should be aware of the fact that view ports are available in glass or quartz. Most view ports on Oxford Instruments Plasma Technology systems are glass, but quartz is used in certain applications. Quartz view ports allow much more UV light to pass through than glass does, and so present a greater hazard. They will require very careful shielding or filtering in ALL situations on Plasmalab and Ionfab systems.

Be careful if the service history of the system is not fully known. It is possible that a glass view port has been changed for a quartz one.

- 1.3.3.4 UV light can also escape from other parts of the system, e.g. from ICP plasma sources, and downstream plasma discharge tubes. Discharge tubes of this type are often made of quartz, and so very careful shielding or filtering is needed.
- 1.3.3.5 UV light can produce ozone from ambient air. Detectable quantities are produced by ICP sources fitted with a quartz tube. Local extraction must be used in this case.

1.3.4 High Temperature

**WARNING****HOT SURFACES - CLOSE CONTACT CAN CAUSE SERIOUS INJURY AND BURNS****Allow sufficient time for heated components (e.g. heated lower electrodes) to cool to room temperature before carrying out maintenance.**

- 1.3.4.1 During operation of the system some components can become dangerously hot. Always allow time for these to cool to a safe temperature before handling them.

Components that become hot include electrically heated chambers, chamber liners, lower electrodes, specimen holders and halogen lamps. Items illuminated by halogen lamps can also reach very high temperatures.

Note that items such as neutralizers, ion sources, and ICP sources operate at high temperatures.

1.3.5 Low Temperature

**WARNING****COLD OBJECTS - CONTACT CAN CAUSE SERIOUS INJURY TO THE SKIN AND CAN CAUSE THE SKIN TO ADHERE TO THE COLD OBJECT****Allow sufficient time for cold components (e.g. cryogenically cooled lower electrodes) to return to room temperature before carrying out maintenance.****If cold objects must be handled, ensure that suitable protective clothing is worn.**

- 1.3.5.1 Beware of the extreme cold produced in refrigerated or cryogenically cooled systems. Contact with the skin by components at these temperatures can produce 'burns'. Allow the cooling system to reach a safe temperature before attempting any maintenance tasks.

Components that become cold include cryogenically cooled lower electrodes, cryogenic pumps and components that use liquid nitrogen.

1.3.6 Gases

Gases are used in the system for venting and purging (N₂), for aiding heat transfer (e.g. helium) and for establishing the process environment (i.e. process gases).

Process gases used in the system are specified dependent on the process for which the system is designed.

The hazards presented by gases fall into one or more of the following categories:

- a) Asphyxiant - replaces Oxygen causing respiration difficulties and eventually death. Examples of asphyxiants are: Nitrogen, Helium etc..
- b) Flammable - can ignite in the presence of heat or arcing.
- c) Toxic
- d) Corrosive

The following WARNINGS may be applicable to the gases used in your system; it is your responsibility to be aware of the hazards and take the necessary precautions. Contact your gas supplier for full details.



WARNING
FLAMMABLE GASES - FLAMMABLE MATERIAL CAN IGNITE IN THE PRESENCE OF HEAT OR ARCING, CAUSING SEVERE INJURY.

After a processing run, the process chamber must be subjected to at least one vent cycle before any maintenance work is carried out.

Ensure that the gas lines have been purged before removing or loosening components.

Wear personal protective equipment as necessary.



WARNING
TOXIC GASES - CONTACT CAN CAUSE DEATH OR SERIOUS INJURY

After a processing run, the process chamber must be subjected to at least two vent cycles before any maintenance work is carried out.

Ensure that the gas lines have been purged before removing or loosening components.

Wear personal protective equipment as necessary.



WARNING
CORROSIVE GASES - CONTACT CAN CAUSE SERIOUS INJURY

After a processing run, the process chamber must be subjected to at least two vent cycles before any maintenance work is carried out.

Ensure that the gas lines have been purged before removing or loosening components.

Wear personal protective equipment as necessary.

**WARNING****PLASMALAB and IONFAB SYSTEMS DO NOT PROVIDE ANY EXCESS PRESSURE REGULATION / PROTECTION FOR PROCESS GASES.****It is the customer's responsibility to ensure that suitable regulation / protection, in accordance with all applicable standards, is installed and correctly maintained external to the system.**

- 1.3.6.1 The effluents of all Plasmalab and Ionfab systems should be considered toxic.
- 1.3.6.2 Ensure that effluents are extracted into a safe disposal system. The bore of the extraction pipework must be of a greater internal bore than the pump outlet. Exhaust lines carrying hazardous gases must not be used for any other purpose.
- 1.3.6.3 Rotary and turbomolecular pumps **MUST** always be nitrogen ballasted, if this feature is provided on the system. For Plasmalab deposition systems, the oil box of the rotary pump should also be purged. If a flow switch and alarm are needed on any of these lines to ensure safe operation, they must be installed and regularly maintained.
- 1.3.6.4 If toxic, flammable or corrosive gases are to be used, the entire system must be installed in accordance with best practice for the semiconductor production industry.

If no local guidelines are available, the regulations contained in U.S. documents UBC 9.911 (1985) and UFC 51 are recommended reading. Guidance is also contained in 'The Safe Storage, Handling and Use of Liquid Gases in the Micro-Electronics Industry' BCGA/ECIF COP CP18, ISBN 0260 - 4809, available from BCGA or ECIF.
- 1.3.6.5 If toxic, flammable or corrosive gases are to be used, the entire system must be situated in a purged or extracted environment with suitable gas detectors.
- 1.3.6.6 Gas pods supplied by OIPT incorporate a 100mm diameter extraction collar. If toxic, flammable or corrosive gases are used, extraction facilities must be connected to this collar. Purge gas extracted from the gas pod should be monitored by a suitable gas detector to give advance warning of any leakage.
- 1.3.6.7 Ensure that the purge gas extraction system can withstand corrosion or combustion if necessary.
- 1.3.6.8 Make regular checks on the vacuum integrity of the gas lines to reduce the risk of sudden leaks.
- 1.3.6.9 Ensure that the system is completely purged **BEFORE** maintenance is started and suitably leak tested **AFTER** maintenance is completed.
- 1.3.6.10 As far as practicable, shut down gas lines when not in use.
- 1.3.6.11 Pumps must always be operated in accordance with the manufacturers' manuals and with Oxford Instruments Plasma Technology engineers' training courses.

Pumps, when fitted with a nitrogen purging facility, must always be purged during a processing run and for a suitable period after a processing run has finished.
- 1.3.6.12 Where gas detectors are fitted, their responses should be verified every two weeks (refer to the manufacturer's manuals).

1.3.7 Materials

- 1.3.7.1 Materials used in the construction of the system are in a safe state when installed. However, fluorine-containing materials may be used as O-rings (e.g. Viton™ materials), as electrical insulation or as electrical isolation block (e.g. Teflon™ or other tfe or ptfe material) or as lubricating grease or fluid (e.g. Fomblin™, Krytox™ or the NCI™ range from Leybold) If any of these materials are overheated, hazardous materials are created that can result in the loss of a limb or death.
- 1.3.7.2 Very great care must be taken to ensure that Perfluoro-elastomer (Viton™) O-rings are not exposed to high temperatures. If overheated, decomposition takes place, producing a highly acidic residue containing hydrofluoric acid (HF).

If there is any evidence that a Viton™ O-ring could have been subjected to temperatures in excess of 300°C the following actions must be carried out:

- (a) Consult a competent authority regarding the following items (b) to (e).
- (b) Wearing suitable protective clothing, remove the O-ring and dispose of it in accordance with local Health and Safety regulations.
- (c) Wearing suitable protective clothing, thoroughly clean the contaminated area, disposing of any residue in accordance with local Health and Safety regulations.
- (d) Fit a new O-ring.
- (e) Investigate the cause of the overheating and review operating procedures and control systems to prevent a recurrence.

- 1.3.7.3 Teflon™ and other tfe materials. Very great care must be taken to ensure that Teflon™ and other tfe or ptfe materials are not exposed to high temperatures. If overheated, decomposition takes place, producing volatile fluorine containing components.

If there is any evidence that any Teflon™ or other tfe or ptfe material could have been subjected to temperatures in excess of 300°C the following actions must be carried out:

- (a) Consult a competent authority regarding the following items (b) to (e).
- (b) Wearing suitable protective clothing, remove the decomposed material and dispose of it in accordance with local Health and Safety regulations.
- (c) Wearing suitable protective clothing, thoroughly clean the contaminated area, disposing of any residue in accordance with local Health and Safety regulations.
- (d) Fit a new component.
- (e) Investigate the cause of the overheating and review operating procedures and control systems to prevent a recurrence.

Note that swarf and other pieces of material for disposal must be disposed of with great care and must be kept well away from fire, from cigarettes and other smoking materials.

- 1.3.7.4 PFPE lubricating fluids. Very great care must be taken to ensure that PFPE fluids (e.g. Fomblin™, Krytox™ NCI™ etc) are not exposed to high temperatures. If overheated, decomposition takes place, producing volatile fluorine containing components.

If there is any evidence that any PFPE lubricating fluids could have been subjected to temperatures in excess of 300°C the following actions must be carried out:

- (a) Consult a competent authority regarding the following items (b) to (e).
- (b) Wearing suitable protective clothing, remove the decomposed material and dispose of it in accordance with local Health and Safety regulations.
- (c) Wearing suitable protective clothing, thoroughly clean the contaminated area, disposing of any residue in accordance with local Health and Safety regulations.
- (d) Replace with fresh grease or fluid.
- (e) Investigate the cause of the overheating and review operating procedures and control systems to prevent a recurrence.

Note that all PFPE material, including spillages of fresh fluid must be disposed of with great care and must be kept well away from fire, from cigarettes and other smoking materials.

1.3.8 Process Chemicals

**WARNING**

SOME MATERIALS USED IN AND RESULTING FROM DEPOSITION AND ETCHING PROCESS CAN BE DANGEROUSLY TOXIC; CONTACT CAN CAUSE SERIOUS INJURY
Before working on the process chamber or its associated components, consult a competent authority to ascertain the nature of any coatings.

Wear appropriate protective clothing, e.g. hand and eye protection, as necessary.

- 1.3.8.1 Some compounds used in and resulting from deposition and etching processes can be dangerously toxic. These compounds can be deposited as coatings on the inside of the chamber, pipework etc. Therefore, suitable hand and eye protection must be used.
- 1.3.8.2 Cleaning fluids and the gases given off from them may be toxic. Only use them in a well ventilated area and avoid ingestion.
- 1.3.8.3 Always use suitable eye and skin protection when handling vacuum pumps and mineral or synthetic oil. Apart from the hazards described in sub-section 1.3.7, used oils and pumps may be contaminated with dangerous chemicals.
- 1.3.8.4 Study all relevant Material Safety Data Sheets (MSDS), or their equivalents, before carrying out any maintenance work.

1.3.9 Vacuum

- 1.3.9.1 Do not enter large vacuum chambers.
- 1.3.9.2 Process chambers and load locks under vacuum represent stored energy. If released accidentally, this can cause injury. These spaces must be vented to atmospheric pressure before the system is powered down in preparation for maintenance.
- 1.3.9.3 Handle vacuum capacitors carefully; if knocked or dropped they can implode causing serious injury.
- 1.3.9.4 All view ports that are greater than 100mm diameter must be fitted with a clear plastic implosion eye-guard on the outside. Replace this item only with the correct part, and ensure that the ports are correctly reassembled.

If a plastic implosion eye-guard is not fitted, or if there is any doubt about the type of eye-guard that is fitted, you must check with Oxford Instruments Plasma Technology before proceeding.
- 1.3.9.5 Take care when opening vented vacuum vessels in case of excess pressure inside.

1.3.10 Compressed air

- 1.3.10.1 Retained air pressures can be at dangerous levels. Never put your hand or any other obstruction in the path of a slit or gate valve blade unless it has been made safe. Release the pressure as follows:
- Power down the system by opening the main circuit breaker.
 - Disconnect the pneumatic supply pipes from the system.
 - Operate and padlock the lock-out valves (if fitted) on the gate valves. This will release all air pressure from both sides of the valve actuators. If lock-out valves are not fitted, disconnect the supply pipe at the point where it connects to the valve.



WARNING
AUTOMATICALLY CONTROLLED COMPONENTS CAN MOVE WITHOUT WARNING
CAUSING SERIOUS INJURY

Maintenance on automatically controlled equipment must only be carried out by fully trained personnel who are aware of the risks involved.



WARNING
PLASMALAB and IONFAB SYSTEMS DO NOT PROVIDE ANY EXCESS PRESSURE
REGULATION / PROTECTION FOR COMPRESSED AIR SUPPLIES.

It is the customer's responsibility to ensure that suitable regulation / protection, in accordance with all applicable standards, is installed and correctly maintained external to the system.

- 1.3.10.2 Before undertaking any work on the system, you must ensure that all compressed air is released. If lock-out valves are fitted, they must be operated and locked. See the section on powering down the system for more details.

1.3.11 Mechanical



WARNING
LIFTING HEAVY OBJECTS INCORRECTLY CAN CAUSE SEVERE INJURY
When handling heavy system components such as the system unit or vacuum pumps, ensure that the appropriate lifting equipment, operated by fully trained personnel, is used.

When heavy rack-mounted components are handled, ensure that the weight is safely distributed between sufficient personnel.

- 1.3.11.1 Injury can be caused by attempting to lift heavy components. Always ensure that suitable lifting equipment and assistance, if required, are available when removing or refitting heavy components, e.g. chamber lids, chamber doors or electrodes.
- 1.3.11.2 Be aware of the weight of racked units, e.g. power supplies. Do not attempt to remove heavy units from their racks unaided.
- 1.3.11.3 Take care when moving heavy components. Ensure that they remain stable to avoid any risk of toppling. Use any support frames or stabilizers provided when moving, installing or decommissioning equipment.

**WARNING****PINCH POINT - LIMBS, FINGERS ETC CAN BECOME TRAPPED RESULTING IN SEVERE INJURY.****Ensure that all personnel are kept clear of pinch points, e.g. chamber doors, hoist mechanisms, variable height electrodes etc, while these components are moving.**

- 1.3.11.4 Close chamber doors carefully; ensure that personnel vacate the vicinity of the door and its operating mechanism before it is closed to avoid trapped fingers etc.
- 1.3.11.5 Handle sprung components under compression or tension carefully, Take suitable precautions, including eye protection, before maintaining small sprung items.
- 1.3.11.6 Beware of machinery in motion such as robotic arms, substrate lifting mechanisms and shutters. Remember that machinery can start suddenly. Ensure that all safety guards are correctly fitted before use.
- 1.3.11.7 Beware of deposition layers under stress. Wear eye protection before cleaning surfaces which are coated with layers of material, as particles can be ejected with considerable force.
- 1.3.11.8 Handle embrittled wire, e.g. filaments, carefully. They can break and become embedded in the skin.









1.3.12 General

- 1.3.12.1 Ensure that local and national Health and Safety standards are studied and followed. It is the customer's responsibility to carry out their own risk assessment and to develop a safe system of work.
- 1.3.12.2 Ensure that all personnel who operate this equipment are trained to use the equipment, and are alerted to the range of hazards present.
- 1.3.12.3 When working with the equipment, ensure that there are always at least two persons present.
- 1.3.12.4 If a tool is used to access or alter any part of the equipment, this is classed as a maintenance action. Persons performing maintenance tasks must be skilled and trained to know and avoid the hazards present. Before carrying out any maintenance work, read the relevant manuals supplied by manufacturers of proprietary components.
- 1.3.12.5 Ensure that the main electrical supply, compressed air, all other gases and the water supply are disconnected before starting maintenance work (Also see sub-section 1.3.9).
- 1.3.12.6 Consult Oxford Instruments Plasma Technology before making any alterations to the system or changing the process gases.
- 1.3.12.7 Ensure that all personnel who may be expected to have access to the system during an emergency, such as firemen, paramedics etc. are familiar with the location of the main circuit breakers and valves.
- 1.3.12.8 Whenever any component is returned to Oxford Instruments Plasma Technology or to any of their agents, it must be accompanied by copies of the Goods Return Form (QCF 60).

- 1.3.12.9 Never smoke or eat in the 'clean room' or where gases are stored. In addition to the fire risks and particulate contamination presented by smoking, some chemicals when burnt generate carcinogenic or toxic compounds.

1.4 Warning and advisory labels









During manufacture, warning and advisory labels are attached to the system to indicate potential hazards and components, which should not be operated or maintained without first reading the relevant manual. Typical labels and their meanings are as follows:

	<p>DANGER RF ENERGY Disconnect electrical supply before servicing</p>	<p>Danger of physical injury from RF radiation or from touching components within the labelled equipment.</p>
	<p>WARNING PINCH POINT Keep hands away from chamber lid when closing.</p>	<p>Danger of trapping limbs, fingers etc. in the labelled equipment.</p>
	<p>WARNING STRONG MAGNETIC FIELD Avoid contact with this area.</p>	<p>Danger of physical injury from the Strong Magnetic Field generated by the labelled equipment.</p>
	<p>WARNING HOT SURFACE Do not touch</p>	<p>Caution, hot surface IEC 417, No. 5041</p>
	<p>DANGER LOW TEMPERATURE Wear thermal protective gloves</p>	<p>Danger of physical injury, from the labelled equipment.</p>
	<p>WARNING SERVICE BY QUALIFIED STAFF ONLY Refer to manual</p>	<p>Read the relevant manual before proceeding to operate or maintain the labelled equipment.</p>
	<p>WARNING RF & UV RADIATION. DO NOT USE THIS PORT FOR VIEWING WITH THE NAKED EYE WITHOUT MESH SHIELD IN PLACE</p>	<p>Danger of physical injury from RF and UV radiation from the labelled components.</p>
	<p>WARNING LASER BEAM Disconnect electrical supply before servicing</p>	<p>Danger of physical injury from Laser Beam generated by the labelled components.</p>

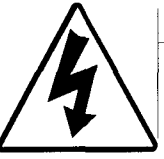

<p>WARNING</p> <p>System vent gas: Nitrogen Max inlet pressure : 5 Bar</p>	<p>Warns of gas type and maximum pressure, connected to the system.</p>
<p>WARNING</p> <p>Gas type: Air (compressed) Max inlet pressure : 9 Bar</p>	<p>Warns of gas type and maximum pressure, connected to the system.</p>
<p>WARNING</p> <p>System process gas : Max inlet pressure : 5 Bar</p>	<p>Warns of gas type and maximum pressure, connected to the system.</p>
<p>WARNING</p> <p>Fluid type: Water (cooling) Max inlet pressure : 4.2 Bar</p>	<p>Warns of fluid type and maximum pressure, connected to the system</p>
	<p>Caution, refer to accompanying documents. ISO 3864, No. B.3.1</p>

Continued...

...Continued

	On (Supply) IEC 417, No.5007
	Off (Supply) IEC 417, No.5008
	Earth (ground) IEC 417, No.5017
	Protective earth (ground) IEC 417, No.5019
	Three phase alternating Current IEC 617-2 No. 020206
	Three phase alternating Current with Neutral wire.
 <p>WARNING HAZARDOUS VOLTAGE Disconnect electrical supply before removing cover</p>	Warns of any voltage between 208V and 240V underneath the cover.
	When used on its own, this label warns of any voltage between 208V and 240V.

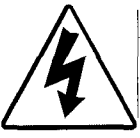
The labels below indicate the presence of high voltages within the labelled equipment. There is a danger of electric shock or burns from touching components within the labelled equipment.

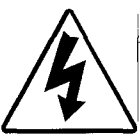
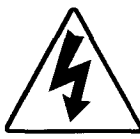
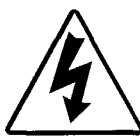
 <p>DANGER HAZARDOUS VOLTAGE 415 Volts 50/60 hz 3 Phase</p>	 <p>DANGER HAZARDOUS VOLTAGE 380 Volts 50/60 hz 3 Phase</p>	 <p>DANGER HAZARDOUS VOLTAGE 208 Volts 50/60 hz 3 Phase</p>
 <p>DANGER HAZARDOUS VOLTAGE 240 Volts 50/60 hz</p>	 <p>DANGER HAZARDOUS VOLTAGE 220 Volts 50/60 hz</p>	 <p>DANGER HAZARDOUS VOLTAGE 115 Volts 50/60 hz</p>

2. Services (ICP 180 & automatic load lock)

2. Services (ICP 180 & automatic load lock)	2-1
2.1 General.....	2-2
2.2 Services requirements	2-3
2.3 Distribution and use of Nitrogen vent and turbo purge gas	2-3
2.4 Services diagrams	2-4

Fig 2.1: System 100 (ICP 180/380) services flow diagram.....2-5

Fig 2.2: System 100 pneumatic circuit diagram.....2-6

2.1 General

The services requirements for the **Plasmalab** System 100 are given in two appendices to this manual:

Appendix S Services Specifications for **Plasmalab** and **Ionfab** Systems. This document gives generic information and mandatory requirements for all services.

Appendix I **Plasmalab** System 100 Installation Data Sheets. This document gives the information necessary to prepare the environment for the **Plasmalab** System 100. Services information includes electrical power consumption and cooling water flow rates. References are made to the relevant mandatory services requirements, listed in 'Services Specifications for **Plasmalab** and **Ionfab** Systems' (see Appendix S).

Services diagrams of the **Plasmalab** System 100 (ICP 180 + automatic load lock) are given in the following drawings:

SP91C24171 System 100 (ICP 180) Services flow diagram

SP91B24018 System 100 Pneumatic circuit

These drawings are located in Volume 2 of this manual. Illustrations of these drawings are also given in sub-section 2.4, page 2-4.

2.2 Services requirements

For details of the services requirements, refer to Appendix IDS and Appendix S.

2.3 Distribution and use of Nitrogen vent and turbo purge gas

Nitrogen (N₂) is supplied to the system via the services panel to allow the process chamber, foreline and automatic load lock to be filled during system venting and to provide a purge gas supply to the turbo pump (if fitted). The N₂ distribution circuit is shown in the services flow diagram; see the following paragraph.

The services flow diagram of the **Plasmalab**System 100 (ICP 180) are given in drawing 94-SP91C24171. This drawing is located in Volume 2 of this manual. An illustration of this drawing is also given at the rear of this Section.

Nitrogen enters the system at the services panel through a ¼" Swagelok bulkhead connector. It is then fed to a regulator and pressure gauge (located behind a panel to prevent unauthorized adjustment) via a stainless steel pipe. The outlet pressure of the regulator can be manually adjusted. To set up the outlet pressure of the regulator, refer to 'Operator Adjustments' in Section 5.

The outlet from the regulator is connected to:

- a) A check valve (over-pressure relief valve).
- b) The turbo pump purge line (if a turbo pump is fitted).
- c) If a Maglev turbo pump is fitted, directly to the turbo pump (for use by the Alcatel turbo controller during system venting).
- d) The process chamber vent line.
- e) The foreline vent line.
- f) The automatic load lock vent line.

Check valve

The check valve is installed to limit the maximum pressure that the regulator can supply. The valve is normally closed and will open at pressures above 5 psi. The outlet of the check valve is fed to the air out connector on the services panel to allow any excess nitrogen to be piped out of the cleanroom if required.

WARNING

IN A NORMALLY VENTED ROOM, THERE IS A LOW RISK OF ASPHYXIA DUE TO VENT GAS DISPLACING AIR.

USERS SHOULD MAKE THEIR OWN RISK ASSESSMENT.

DO NOT REMOVE THE CHECK VALVE OR CAP THE AIR OUT CONNECTOR; THIS WOULD COMPROMISE A SYSTEM SAFETY FEATURE.

Turbo pump purge line

The turbo purge line supplies nitrogen to the turbo pump purge gas inlet via a mass flow meter, restrictor and the turbo purge valve. The mass flow meter's readback is monitored by the PC 2000 software. If the nitrogen flow is too low, this state is detected by the PC 2000

software to display a blue system alert followed after three minutes by a red system alert and subsequent system shut down to prevent damage to the turbo pump. For details of system alerts, see Section 5 (Operating Instructions.).

The turbo purge valve is pneumatically controlled by the system software.

Process chamber vent line

The process chamber vent line supplies nitrogen to the process chamber during the venting sequence via a restrictor and chamber vent valve. The chamber vent valve is pneumatically controlled by the system software.

Foreline vent line

The foreline vent line supplies nitrogen to the foreline during the venting sequence to prevent backstreaming of vapour from the rotary vane pump. Nitrogen is fed from the regulator to the foreline via a restrictor and the foreline vent valve. The foreline vent valve is opened for a period when the primary vacuum pump is turned off.

Automatic load lock vent line

The automatic load lock vent line supplies nitrogen to the automatic load lock during the venting sequence via a restrictor and chamber vent valve. The chamber vent valve is pneumatically controlled by the system software.

2.4 Services diagrams

The services flow and pneumatic circuit are shown in the following diagrams. Note that these are typical schematics; actual components fitted depend on the options supplied.

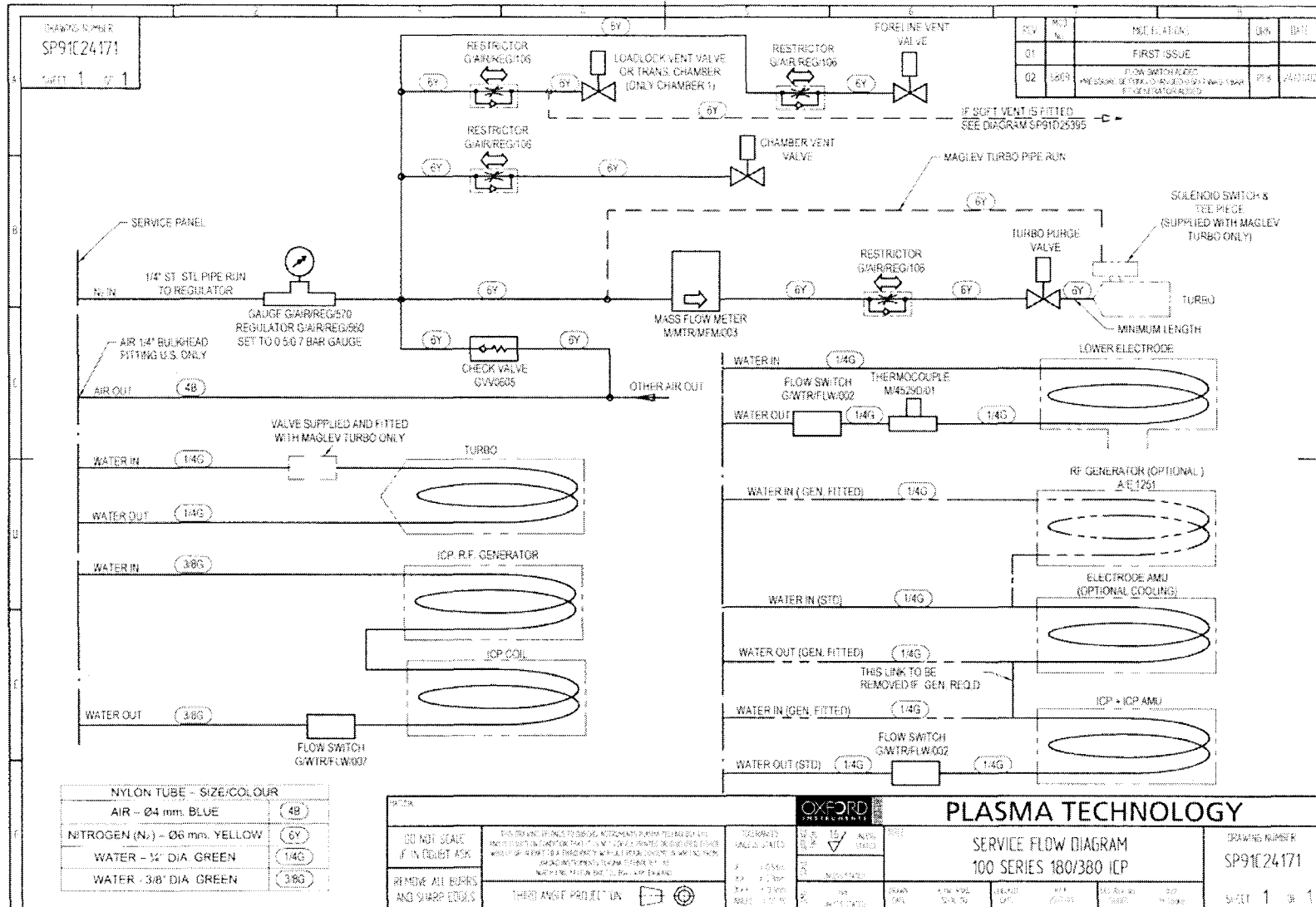

Fig 2.1: System 100 (ICP 180/380) services flow diagram

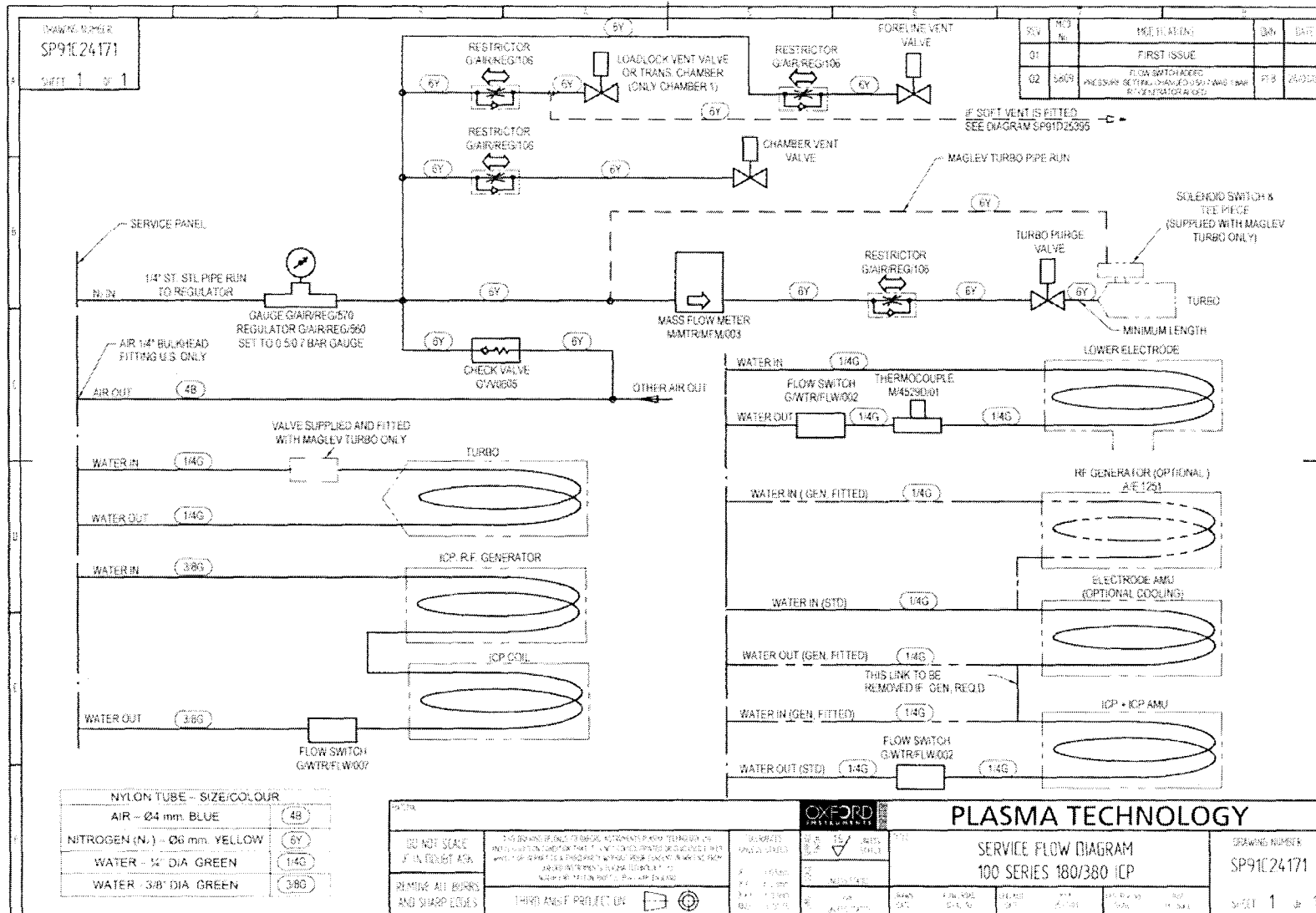

Fig 2.1: System 100 (ICP 180/380) services flow diagram

3. Description

3. Description	3-1
3.1 Introduction	3-2
3.2 PC 2000 Hardware and software with licence	3-2
3.2.1 Hardware.....	3-2
3.2.2 PC 2000 software and single-user licence.....	3-2
3.3 94-100-0-RIE RIE base unit	3-2
3.3.1 Frame.....	3-3
3.3.2 Power box assembly.....	3-3
3.3.3 System controller.....	3-3
3.3.4 Interlocks.....	3-5
3.3.5 Services.....	3-6
3.4 94-100-3-41C ICP 180 chamber kit with gate valve	3-7
3.4.1 94-100-3-00/21P Process chamber electrical heating kit.....	3-8
3.4.2 94-100-3-00/05 200mm Pumpdown pipe heater kit.....	3-8
3.5 94-100-5-12A Cryo / heated -150/400C helium-assisted lower electrode	3-9
3.6 94-100-6-500/200 500W RF generator / OIPT AMU kit	3-12
3.7 94-100-6-56 ICP 180 Inductively Coupled Plasma Source	3-12
3.8 Vacuum system	3-12
3.9 Gas handling system	3-14
3.9.1 94-81-9-51/8 Gas pod (PLC version).....	3-14
3.9.2 94-81-9-11 Standard non-toxic gas line.....	3-16
3.9.3 94-81-9-21 Standard toxic gas line.....	3-17
3.9.4 94-81-9-00/4 Gas line interlock kit.....	3-17
3.10 94-100-10-05C Single wafer automatic load lock	3-18
3.10.1 Wafer transfer mechanism operating principle.....	3-19
3.10.2 Functional Description.....	3-20
3.10.3 Wafer support (end effector).....	3-22
Fig 3.1: Typical control system.....	3-4
Fig 3.2: 94-100-3-41C process chamber.....	3-7
Fig 3.3: 94-100-5-12A Cryo / heated -150 / 400C He lower electrode.....	3-11
Fig 3.4: UC Davis 94-721001 vacuum system.....	3-13
Fig 3.5: 94-81-9-51 Gas pod.....	3-15
Fig 3.6: 94-81-9-11 Standard non-toxic gas lines.....	3-16
Fig 3.7: 94-81-9-21 Standard toxic gas line.....	3-17
Fig 3.8: Single wafer automatic load lock.....	3-18
Fig 3.9: Simplified wafer transport mechanism operation.....	3-19
Fig 3.10: Automatic load lock, side view.....	3-20
Fig 3.11: Automatic load lock wafer transport mechanism.....	3-21
Table 3.1: Consequences of open circuit interlocks.....	3-6

3.1 Introduction

The **Plasmalab** System 100 is a modular plasma processing system. It can be configured to carry out Reactive Ion Etching (RIE), Plasma Enhanced Chemical Vapour Deposition (PECVD), Inductively Coupled Plasma (ICP) and Electron Cyclotron Resonance (ECR) processes.

The system can be tailored to suit different rates of throughput using transfer and load lock chambers with manual or automatic loading.

Combinations of processes can be achieved by using a transfer chamber robot to serve up to four process chambers.

3.2 PC 2000 Hardware and software with licence

3.2.1 Hardware

The system is controlled and monitored by a PC compatible computer with a Microsoft Windows Operating System. The computer is fitted with a floppy disk drive and a CD-ROM drive to allow software updates. An Arcnet interface card, for communicating with the Programmable Logic Controllers (PLCs), is fitted in one of the expansion slots. If required, a modem can be fitted to use the 'PC Anywhere' software.

3.2.2 PC 2000 software and single-user licence

The PC 2000 control software runs as a Windows-based application allowing multiple levels of system control: SYSTEMS MANAGER, SYSTEMS ENGINEER, PROCESS DEVELOPER, MAINTENANCE ENGINEER, PROCESS EDITOR and OPERATOR, all of which are accessed by password entry.

The system status is displayed on graphic mimic diagrams with all operational parameters and status displays accessible through pop-up windows selected using the mouse. All the major process parameters are accessible from the recipe and process step set-up pages, including definition of gases on each line and calculation of mass flow settings in sccm's. The software includes data logging to disk of user-selectable run-time process parameters for off-line verification and analysis of process conditions.

Processing recipes can be formulated and stored in the computer and the system can be run in fully automatic mode using the recipes. Alternatively, the system can be run in the manual mode with each phase of the process controlled and initiated separately. All the parameters can be monitored in real time using the PC 2000 software.

3.3 94-100-0-RIE RIE base unit

The **Plasmalab** System 100 process module base unit houses the process chamber, electronic sub systems, control units, services and power supplies.

The module is mechanically MESC compatible and is constructed using proven Oxford Instruments Plasma Technology hardware designs.

The system is fully interlocked to protect the system hardware from service failure and to protect the operator from electrical shock during maintenance procedures. A lock out valve and associated padlock, mounted on the frame, can be used to prevent operation of all pneumatically operated devices during servicing.

3.3.1 Frame

The frame is constructed from steel with removable access panels. Casters and adjustable feet fitted to the bottom of the frame enable it to be easily manoeuvred, then levelled and locked into position.

3.3.2 Power box assembly

The power box assembly is mounted on the outside of the frame. This distributes mains power to the +24V and $\pm 15V$ power supply unit, the frame mounted electrical units and the remote auxiliary units. For circuit details of the unit, refer to the relevant drawing in Volume 2 of this manual.

A 24V EMO (Emergency Off) circuit connects all the EMO buttons mounted externally on the machine. If any of these EMO buttons are pressed in, all the power outputs from the power supply boxes are disabled.

NOTE: Freestanding auxiliary units such as water recirculators, Residual Gas Analysers, and the system control PC, are not powered via the base unit power box. These require dedicated electrical service points. These accessories remain live when the system EMO is pressed.

If it is required that all accessories are powered off when the EMO is pressed, the user must supply a power distribution unit with outlets for the accessories, and contact the factory for electrical access to the machine EMO circuit.

3.3.3 System controller

The system is controlled from a remote IBM compatible PC computer terminal using Oxford Instruments Plasma Technology's 'PC 2000' software via a Programmable Logic Controller (PLC) housed in the console cabinet. See Fig 3.1.

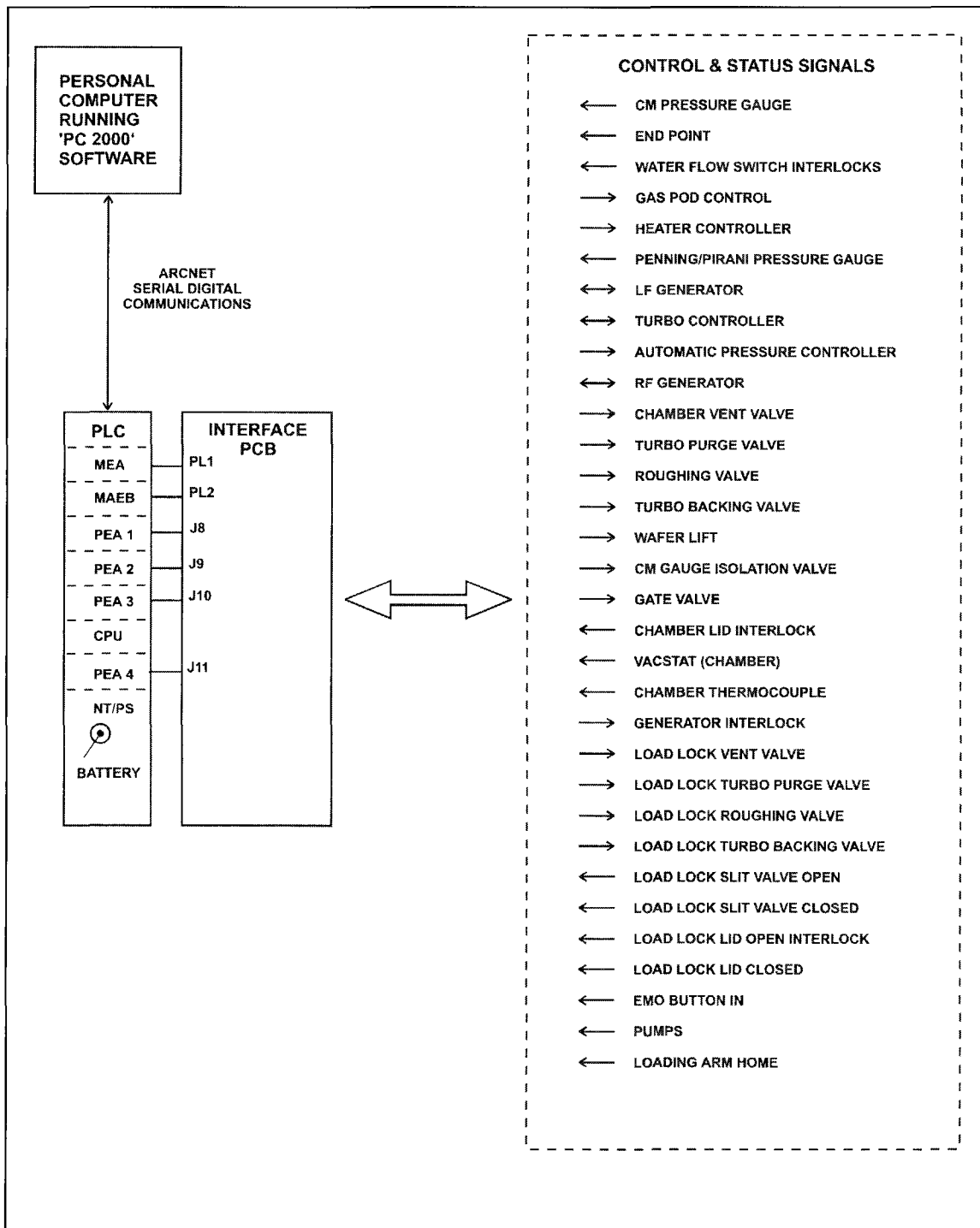

Fig 3.1: Typical control system

The system may be run from the PC terminal in manual mode, that is using direct 'real time' control over the process, or in automatic mode where the system performs the entire process according to previously entered recipes. The extensive Oxford Instruments Plasma Technology process library supports all **Plasmalab** System 100 configurations. A full description of the 'PC 2000' control instructions is provided in Section 5.

For details of the control wiring, see the relevant drawings in Volume 2 of this manual.

3.3.4 Interlocks

There are two types of interlocks used on the **Plasmalab** System 100, hardware and software. In all areas, the hardware interlock will override any software interlock. The hardware interlocks, and their effect on the system components in the case of an interlock becoming open circuit are as follows:

The electrical interlocks are divided into two circuits controlling the power to the system.

- 1) The mains power connection is made to a system Power Distribution Unit. The Power Distribution Unit will disable all of its power outputs under the following conditions:
 - a) If the Emergency Off button is pressed.
 - b) If there is an interruption of the power input to the system.
 - c) If the Power Distribution Unit external facility interlock sensor link becomes open circuit.

NOTE: The Power Distribution Unit external facility interlock sensor link enables the interlocks of external sensors, e.g. gas detectors, exhaust scrubbers, etc., to be monitored by the Power Distribution Unit. External interlock contacts connected to this link should be Normally Closed, i.e. faulting to an Open Circuit.

- 2) The system internal 24V supply, comprises a process line, a chamber lid line and a water flow switch (where fitted):

The 24V process line, which controls the process gases and plasma power supply units, will be disabled if the Vacuum Safety Switch is open circuit, i.e. Chamber Pressure > 600 mbar.

The 24V chamber lid line will be disabled if the chamber lid is OPEN, leaving the system controller operational, but disabling all system components.

Interlock	Emergency Off / Electrical Fail		24V Process line		24V Chamber lid line	
	Fail	Restore	Fail	Restore	Fail	Restore
System/Controller	OFF	Restart Required	ON		ON	
RF Generator	OFF	Powered, NOT active	OFF	Powered, NOT active	OFF	Powered, NOT active
Process Gases	OFF	Powered, NOT active	OFF	Powered, NOT active	OFF	Powered, NOT active
Automatic Pressure Controller Valve	CLOSED	CLOSED	** NO CHANGE	NO CHANGE	CLOSED	CLOSED
Load lock Slit Valve	HOLD	* HOLD	HOLD	HOLD	HOLD	HOLD
Pumps	OFF	Pumps must be restarted	NO CHANGE	NO CHANGE	OFF	Pumps must be restarted
* If closed, stays closed. If open, will stay open until the loading arm is at its home position; then it will close.						
** If 'high pressure' is signalled during process, APC opens and process step aborts. High pressure at other times does not alter the APC.						

Table 3.1: Consequences of open circuit interlocks

Other machine protection switches include:

- a) A water flow switch. Low flow is reported to the system controller, which disables specific devices until flow is restored.
- b) Pump overload detection. If the primary pump stops because the over-current protection switch opens, then the system aborts.

The software also monitors the position of the wafer handling mechanisms, ensuring safe operation.

3.3.5 Services

For details of the services required for the base unit, refer to Section 2 of this manual.

3.4 94-100-3-41C ICP 180 chamber kit with gate valve

The ICP chamber kit comprises the following components:

Process chamber.

Pumping port isolation valve and automatic pressure controller suitable for use with a turbomolecular pump.

The ICP process chamber, shown in Fig 3.2, is machined from a single aluminium block with the minimum number of O-rings to provide the highest vacuum integrity.

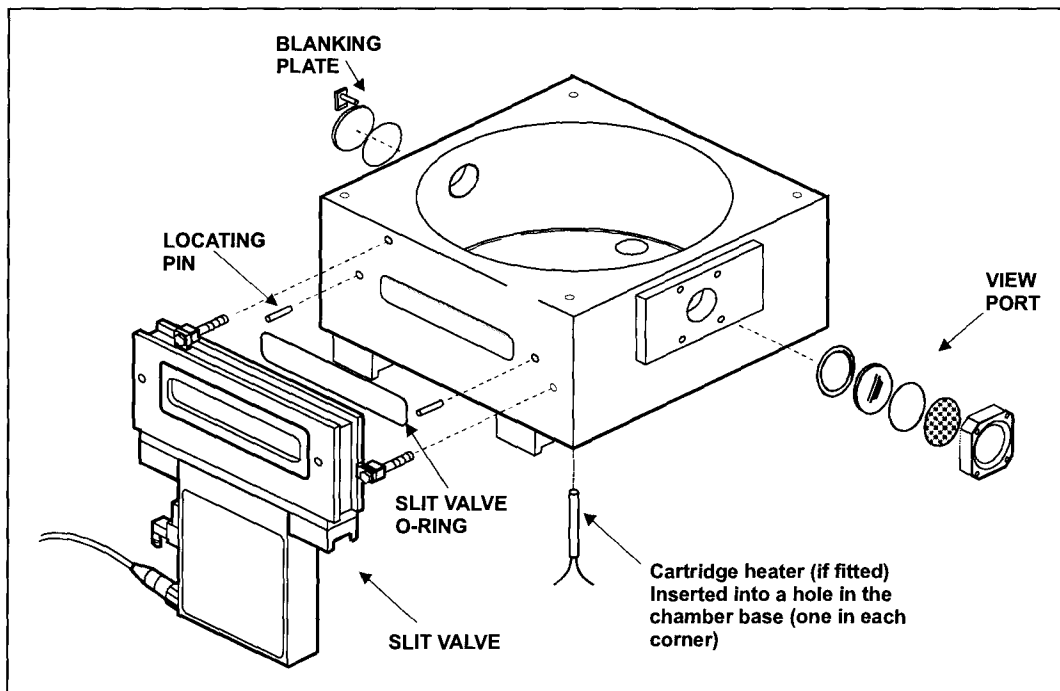

Fig 3.2: 94-100-3-41C process chamber

The chamber is fitted with the following ports:

- a) Single view port fitted with an RF shield for viewing the plasma. Note that the view port is mounted on a blanking plate, which can be removed to provide access to the chamber interior.
- b) Pumping port.
- c) Wafer transfer port to which is attached a pneumatically operated gate valve.
- d) Wafer clamp port.
- e) Process gas inlet port.
- f) Two ports for the connection of vacuum measurement components.

The pneumatically operated gate valve, for connecting to the selected wafer insertion device, is attached to the chamber by six claw bolts and is positioned by two locating pins (dowels). Sealing is provided by a rectangular O-ring.

3.4.1 94-100-3-00/21P Process chamber electrical heating kit

The electrical heating kit comprises four cartridge heaters; inserted into holes at the corners in the base of the process chamber, see Fig 3.2. Heater control is via a unit mounted on the console, where the temperature can be set manually. A temperature in the range 50°C to 60°C is recommended for most processes.

WARNING

IF THE PROCESS CHAMBER TEMPERATURE IS SET TO A VALUE ABOVE 60°C, CONTACT WITH IT CAN CAUSE BURNS.

BEFORE OPERATING THE CHAMBER ABOVE 60°C, ENSURE THAT EXTERNAL HEAT SHIELDS ARE FITTED.

3.4.2 94-100-3-00/05 200mm Pumpdown pipe heater kit

This heating kit is applied to the pump-down pipe to give optimum vacuum performance and to minimise the deposition of loosely adherent material, which might generate particulates.

3.5 94-100-5-12A Cryo / heated –150/400C helium-assisted lower electrode

The helium-assisted lower electrode, shown in Fig 3.3, is fabricated from aluminium. The electrode is fitted with an integral dark space shield.

The lower electrode is heated by an embedded 1250W element and cooled by liquid nitrogen flowing through embedded tubing.

Wafer lift

The wafer is lifted clear of the table (15mm) for transferring into a load lock or transfer chamber by the wafer lift assembly. Compressed air flowing into the air cylinder forces its piston and plunger upwards. The plunger contacts the base of the bellows which is connected to a push rod. The 3-pin wafer support, mounted on top of the push rod, rises lifting the wafer clear of the table. The push rod is lowered by the force exerted by the return spring.

Wafer clamp

The wafer clamp comprises a clamping ring attached to a lifting mechanism, and a clamping plate. The clamping plate, attached to the clamping ring via three pillars and screws, comprises an aluminium annulus with a quartz circular insert.

The wafer clamp is raised and lowered by two air cylinders, attached to the outside of the process chamber; one located at each side of the wafer clamp. The piston of each air cylinder is attached to a push rod, which passes through the base of the process chamber. Within the process chamber, a circular plate mounted on the top of the push rod, is attached to the wafer clamp by three M5 setscrews and compression springs. Rotating the setscrews changes the compression of the springs and consequently the clamping force exerted on the wafer. See Section 6 for the clamping force adjustment procedure.

Note that clamping plates are available with inserts for various sized wafers. Before loading a wafer into the process chamber, ensure that the correct clamping plate is fitted. See Section 6 for the clamping plate changeover procedure.

Table top plate

In some systems, the table top plate is fixed to the table by a ring of cap-head bolts. If your system has a table of this type, refer to the following text and note.

The bolt heads are concealed behind screw covers, which require a special tool (supplied with the system) for removal. (Tool part number: MD91D21726.)

- NOTES:**
- 1) When re-fixing the table top, do not over-tighten the bolts which will cause the table top to bow. Check with a straight edge after tightening: if the table top is not flat, release the bolt tensions until it is.
 - 2) The screw covers (MD91D21723) are aluminium. When removing the covers, it is recommended to use a little iso-propyl alcohol (IPA) to prevent the thread from jamming.

Helium backing

The purpose of helium backing is to set the temperature of the wafer close to that of the temperature-controlled table by heat transfer. Helium is fed from a number of small holes in the table underneath the wafer (which is clamped to the table) from where it flows radially

to the periphery of the wafer. Helium is the preferred gas, because it has a very good heat transfer ability. The use of other gases is possible, preferably inert gases.

The supply of helium is fed by a pressure control device, which receives an analogue setpoint from the machine's control system. The pressure control device adjusts the gas flow through itself to control the pressure at its output side. The pressure is controlled within the range 0 to 50 Torr. A pressure of greater than 20 Torr could damage very thin substrates.

If the wafer is clamped down successfully the chamber pressure will show a slight rise of a few milliTorr when the helium is producing a pressure of 10 Torr on the wafer.

If there is a massive pressure rise and the Turbo Controller display shows a high load, then the wafer is insufficiently clamped and in order to achieve the set pressure the controller is using an excessive gas flow.

The helium pressure is released into the process chamber at the end of a process (using a normally-open valve). This prevents the wafer moving when it is unclamped.

Tip: Finish a process with a ten-second pumping step without helium. This will reduce wafer mishandling.

A flow meter in the helium supply also reads the gas flow necessary to maintain the pressure. A typical process uses 5 - 20 sccm to maintain 10 -15 Torr behind the wafer.

Tip: Some wafers mate very well with the electrode top surface and use less than 2 sccm to maintain 10 Torr. This can give a control problem, with the helium feeding in pulses. Roughening the aluminium electrode with an abrasive pad can increase the helium flow by a few sccm and allow proper control.

Do not turn on the helium unless the wafer is clamped.

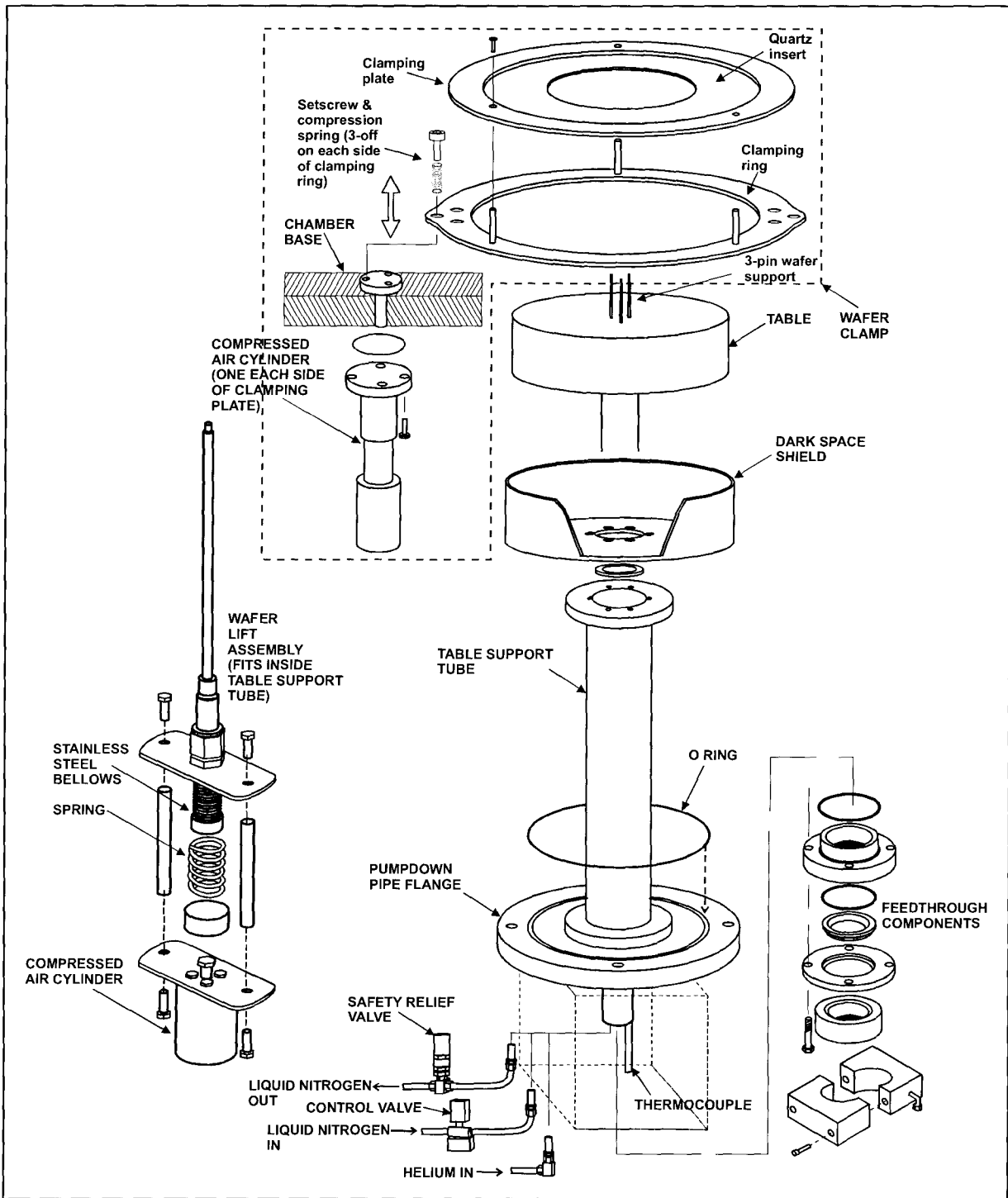

Fig 3.3: 94-100-5-12A Cryo / heated -150 / 400C He lower electrode

3.6 94-100-6-500/200 500W RF generator / OIPT AMU kit

This kit comprises a 500W RF Generator and an OIPT Automatch Unit.

The RF generator produces a 13.56MHz output, which is fed via the automatch unit to the lower electrode to produce the plasma. The automatch unit adjusts the impedance of its output to match the impedance of the lower electrode to ensure maximum power transfer.

For details of these units, refer to the manufacturer's literature in Volume 3 of this manual.

The automatch unit can be manually adjusted if necessary, see Operator Adjustments in Section 5 of this manual.

3.7 94-100-6-56 ICP 180 Inductively Coupled Plasma Source

The inductively coupled plasma source is 180mm in diameter, which gives uniformity suitable for use with wafers up to four inches in diameter. An RF generator (3kW 13.56MHz) and automatch unit are included. A quartz or alumina discharge chamber is supplied, according to the process specification. For full details of this source, refer to the ICP 180 manual (provided as a supplement to this manual – refer to the contents list).

3.8 Vacuum system

The vacuum system is shown in Fig 3.4.

The process chamber is pumped by an Alcatel ATP900 turbomolecular pump via an Automatic Pressure Controller (APC). The turbomolecular pump is backed via an isolation valve by an Alcatel 2063 C2 rotary vane pump.

The process chamber process pressure is measured by a temperature compensated 100-mTorr Capacitance Manometer gauge. Note that the CM gauge output does not stabilise until it has been switched on and under vacuum for 15 minutes.

Base pressure is measured by an active Penning gauge, which is disabled at pressures above 10 mTorr.

A Vacuum Switch monitors the chamber pressure. When the pressure falls below 600 mbar, its contacts close to enable the 24V process line and allow the process gases and the RF to operate.

The automatic load lock is pumped by an Alcatel 2015 C2 rotary vane pump. A Pirani gauge measures pressure.

For details of the vacuum pumps and gauges, refer to the manufacturer's literature in Volume 3 of this manual.

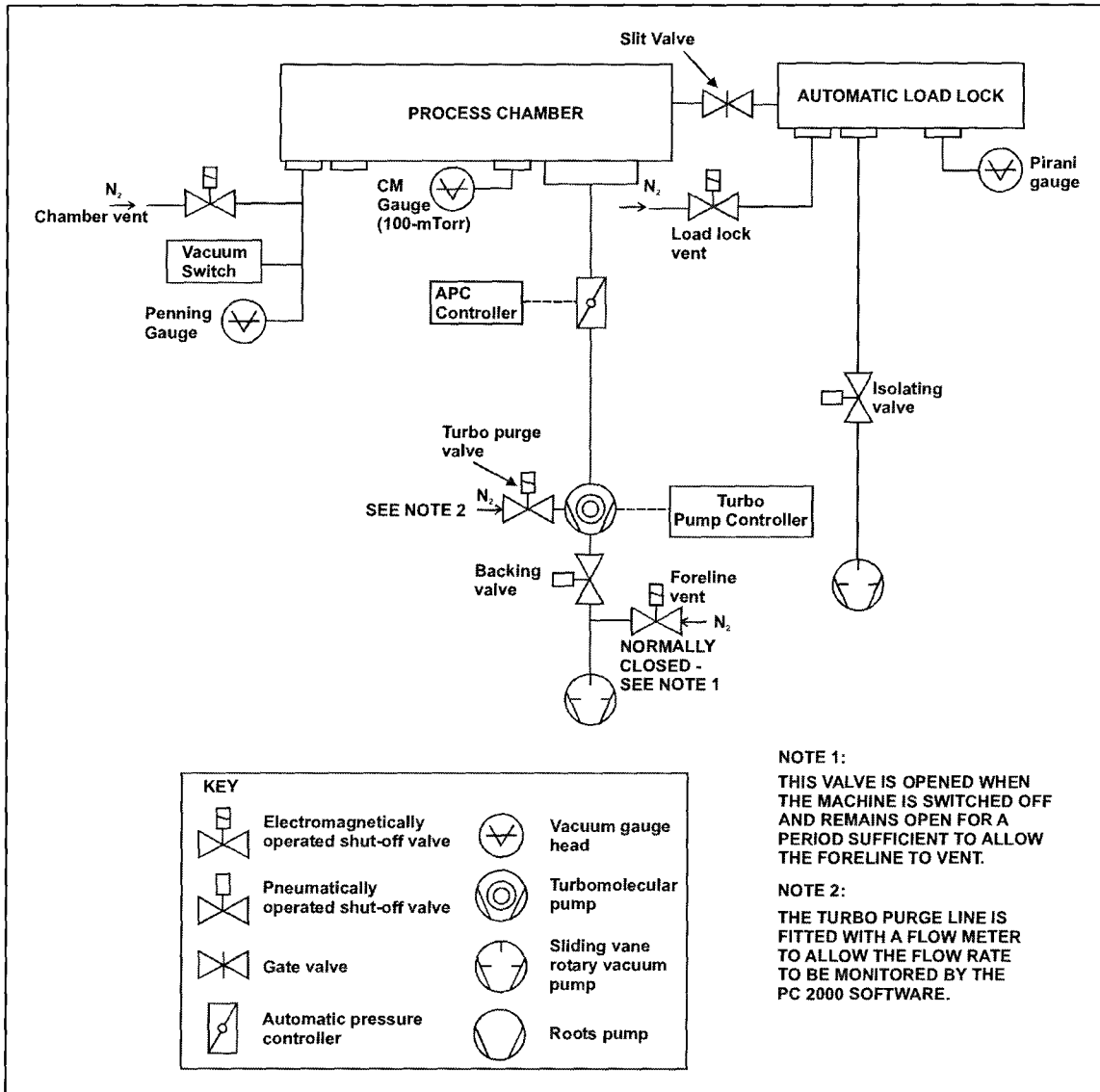

Fig 3.4: UC Davis 94-721001 vacuum system

3.9 Gas handling system

WARNING

CONTACT WITH TOXIC GASES CAN CAUSE DEATH OR SERIOUS INJURY.

USERS SHOULD PERFORM THEIR OWN RISK ASSESSMENT OF HAZARDOUS GASES TO BE USED ON THE SYSTEM.

BEFORE VENTING THE PROCESS CHAMBER, ALWAYS ENSURE THAT THE SYSTEM IS ADEQUATELY PURGED AND PUMPED; SEE 'VENTING THE SYSTEM' IN SECTION 5 OF THIS MANUAL.

3.9.1 94-81-9-51/8 Gas pod (PLC version)

The purpose of the gas pod is to feed a mixture of process gases, at specified flow rates, to the process chamber. Selection of gases and flow rates are determined by the system controller. A 'clean gas' line can be incorporated to feed an etch gas mixture into the process chamber to remove process residues.

The gas pod, shown in Fig 3.5, comprises a steel case with a removable cover. An extraction collar at the top of the case enables any leaked gas to be safely removed by a laboratory extraction system. The back panel of the case is fitted with fixing holes for wall or frame mounting.

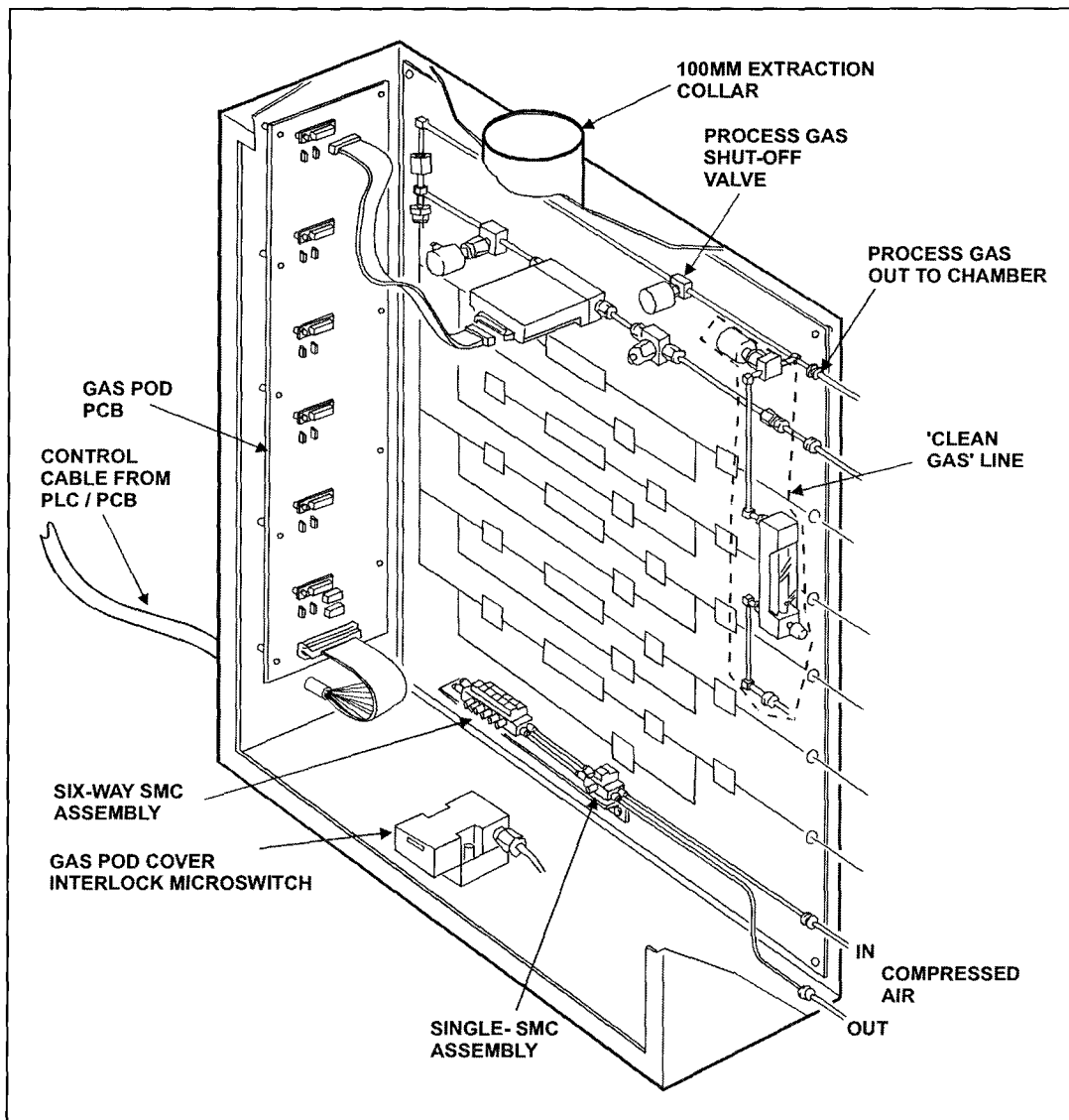

Fig 3.5: 94-81-9-51 Gas pod

The case incorporates stations for up to six gas lines. The outputs from the gas lines are fed into a common manifold which is connected to the process chamber gas line. Pneumatically operated shut-off valves in each gas line are driven by associated SMC valves, powered by compressed air and controlled by signals from the system controller. A separate SMC valve, controlled by an interlock microswitch, prevents the opening of any gas shut-off valve when the case cover is not fitted, or when either of the system interlock lines are open.

The Gas Pod PCB receives signals from the system controller, to control the SMC valves, and the Mass Flow Controllers (MFC) fitted in the gas lines. For a circuit diagram of the Gas Pod PCB, refer to drawing SE81D15942 in Volume 2 of this manual.

The 'clean gas' line flow rate can be set either manually by a variable valve (as shown in Fig 3.5) or by an MFC. Note that the 'clean gas' is usually supplied from a cylinder containing the required gas mixture. An alternative method is to mix separate gases in optional additional gas lines.

WARNING

THE CONNECTION FROM THE GAS POD MANIFOLD TO THE PROCESS CHAMBER SHOULD NOT INCLUDE ANY SHUT OFF VALVE, UNLESS THIS HAS BEEN CLEARED WITH OXFORD PLASMA TECHNOLOGY. A BLOCKAGE HERE COULD CAUSE PROCESS GASES TO MIX AND CROSS CONTAMINATE IN THE HIGH PRESSURE GAS DELIVERY PIPEWORK.

3.9.2 94-81-9-11 Standard non-toxic gas line

The standard non-toxic gas line is shown in Fig 3.6. All gas fittings are VCR and all stainless steel pipework connections are welded. The 'gas in' tube passes into the side of the case, protected by a grommet. A ferrite core, fitted to the 'gas in' tube, reduces the susceptibility of the gas pod electronics to signals from nearby transmitting devices, e.g. mobile phones, modems, etc..

Gas from the customer's cylinder/regulator/filter flows into the gas in tube to the filter.

The gas flows through the 2- μ m filter to the mass flow controller (MFC). The MFC controls the flow of gas as commanded by the system controller. The gas then flows through the pneumatically controlled outlet shut-off valve and into the gas out manifold where it is mixed with the other process gases before flowing into the process chamber.

WARNING

THE CLOSED INLET VALVE REMAINS SHUT FOR DIFFERENTIAL PRESSURE UP TO 5 BAR. A FAILURE UPSTREAM WHICH PRODUCES LINE PRESSURES ABOVE THIS WILL NOT BE CONTAINED. IF THIS PRODUCES A HAZARD, THE CUSTOMER IS WARNED TO FIT ADDITIONAL PROTECTION UPSTREAM.

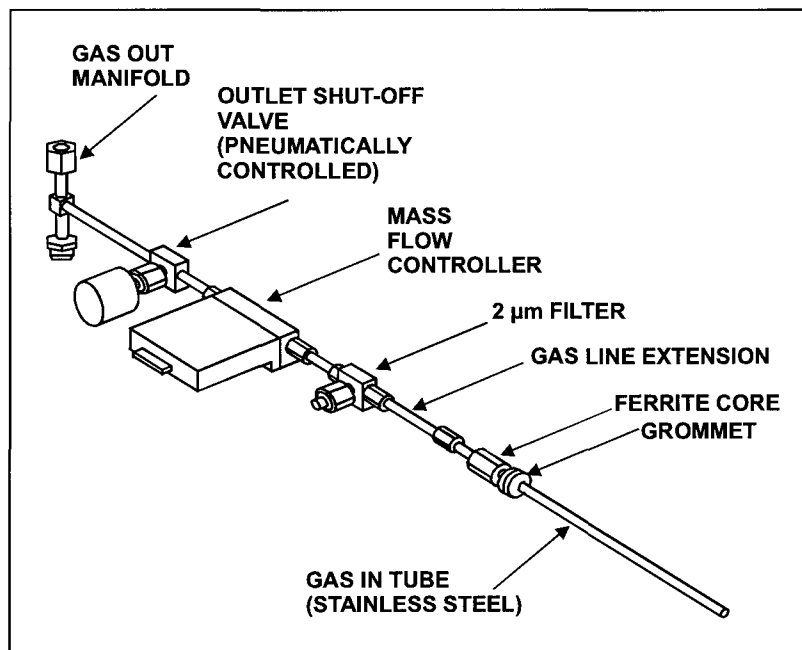

Fig 3.6: 94-81-9-11 Standard non-toxic gas lines

3.9.3 94-81-9-21 Standard toxic gas line

The standard toxic gas line is shown in Fig 3.7. All gas fittings are VCR and all stainless steel pipework connections are welded. The gas in tube passes into the side of the gas pod case, protected by a grommet.

Gas from the customer's cylinder/regulator/filter flows into the gas in tube to the filter.

WARNING

THE CLOSED INLET VALVE REMAINS SHUT FOR DIFFERENTIAL PRESSURE UP TO 210 BAR. A FAILURE UPSTREAM WHICH PRODUCES LINE PRESSURES ABOVE THIS WILL NOT BE CONTAINED. IF THIS PRODUCES A HAZARD, THE CUSTOMER IS WARNED TO FIT ADDITIONAL PROTECTION UPSTREAM.

With the Inlet Valve and Outlet Valve open and the Bypass Valve closed, the gas flows through the 2 μm filter to the mass flow controller (MFC). The MFC controls the flow of gas as commanded by the system controller. The gas then flows through the outlet valve and into the gas out manifold where it is mixed with the other process gases before flowing into the process chamber.

With the Bypass Valve open, the gas flows through the bypass line directly to the gas out manifold. This facility is provided to enable the toxic gas line to be evacuated by pumping down the process chamber. This is necessary to prevent air entering the gas line and contaminating it during a gas cylinder changeover, and to service the gas line in the event of an MFC or filter blockage.

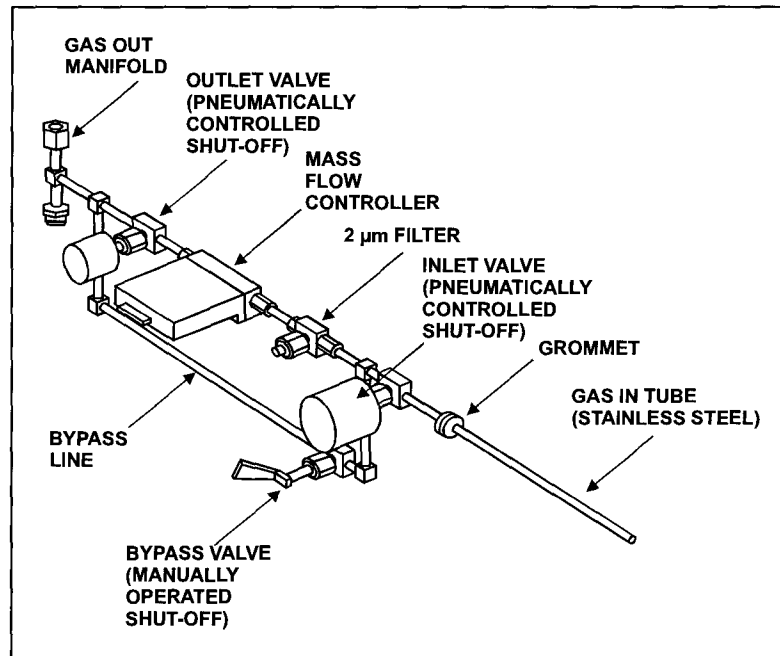

Fig 3.7: 94-81-9-21 Standard toxic gas line

3.9.4 94-81-9-00/4 Gas line interlock kit

The gas line interlock kit is a pneumatically controlled hardware interlock, which prevents the simultaneous flow of process gases, which if combined could produce a hazardous mixture.

3.10 94-100-10-05C Single wafer automatic load lock

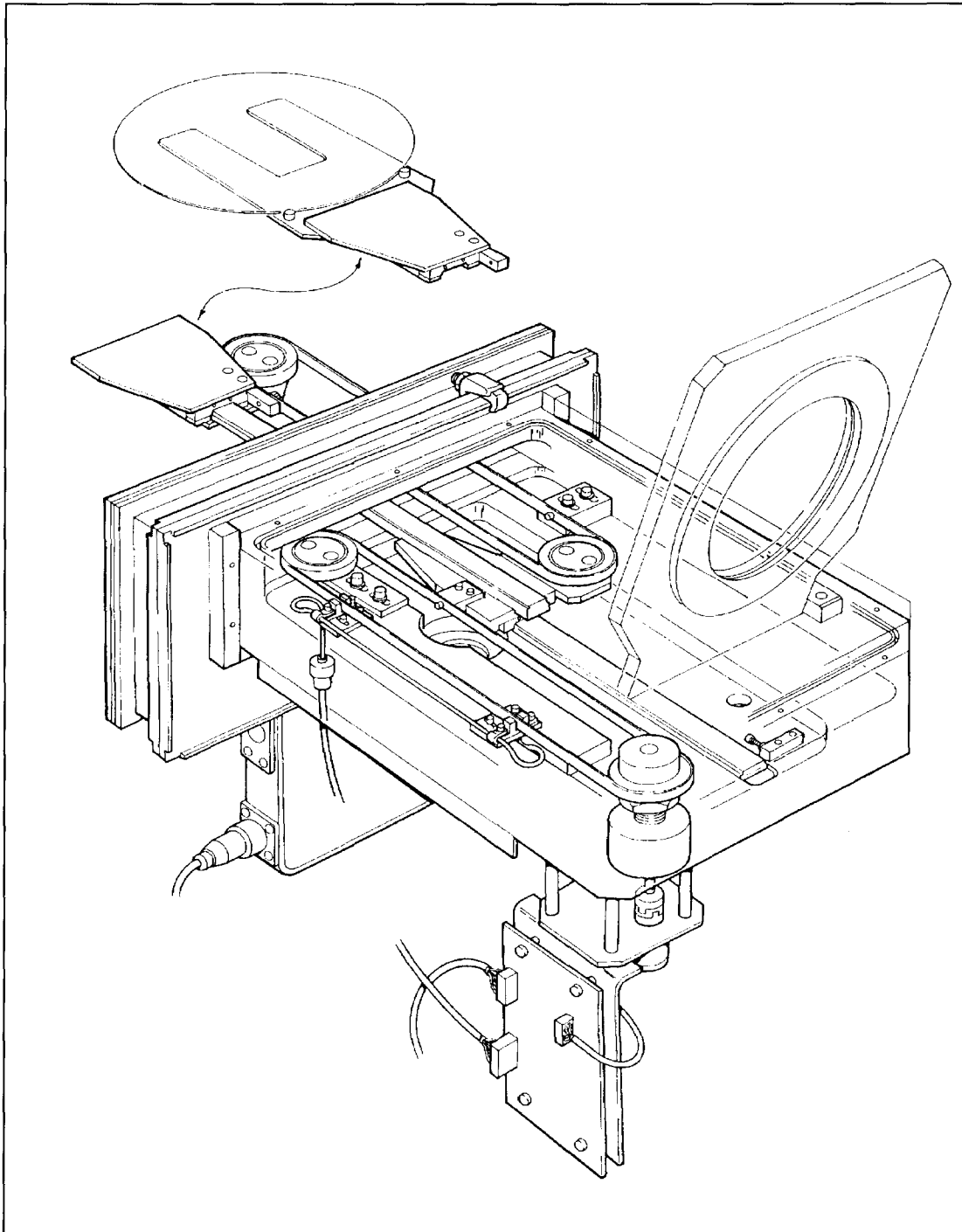

Fig 3.8: Single wafer automatic load lock

The automatic load lock, shown in Fig 3.8, enables wafer loading and unloading to be automatically achieved under vacuum. These operations are controlled by computer, requiring minimum operator involvement. The Oxford Instruments Plasma Technology design results in a very compact load lock (395 mm long with 400 mm of wafer support travel). The load lock is capable of handling MESC¹ standard wafers up to 200 mm diameter.

3.10.1 Wafer transfer mechanism operating principle

The operating principle of the automatic load lock wafer transfer mechanism is shown in Fig 3.9. This simplified illustration shows the three major components of the mechanism: the fixed track, the carriage and the wafer support.

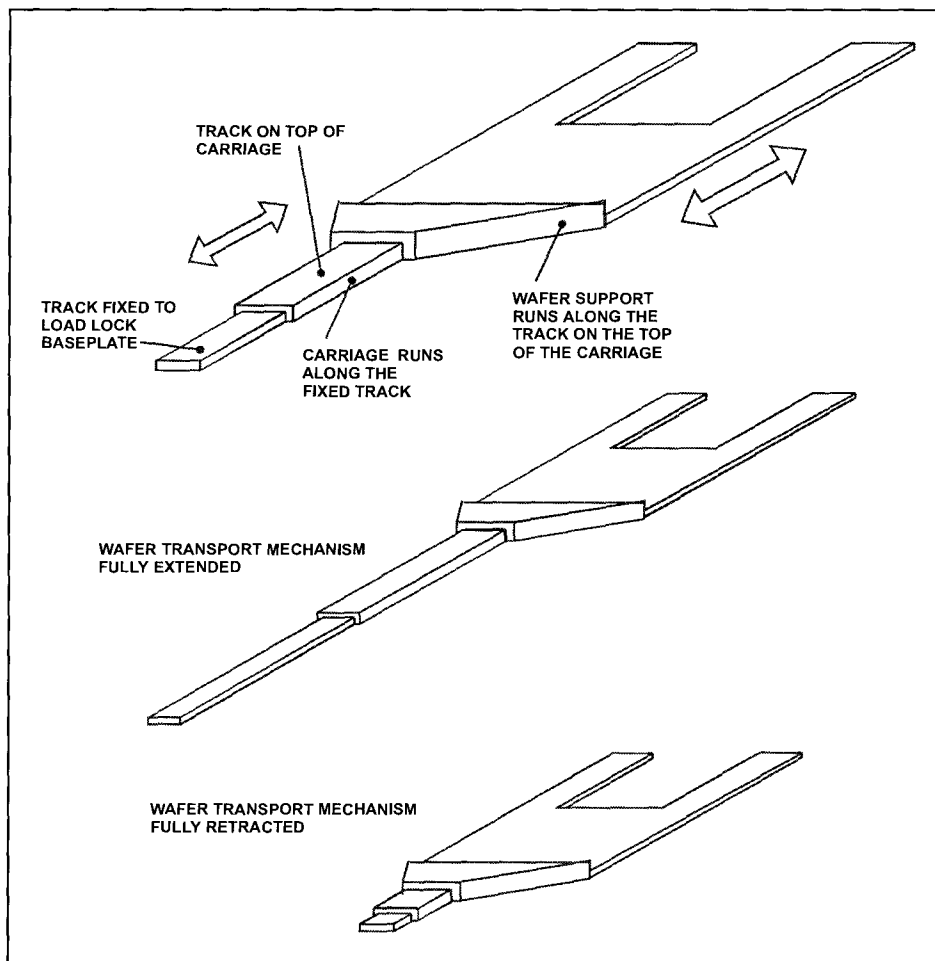

Fig 3.9: Simplified wafer transport mechanism operation

The fixed track is mounted on the load lock's baseplate and provides the bearing surface on which the carriage runs. The carriage also has a top bearing surface on which the wafer support runs.

When the mechanism is driven, the carriage runs along the fixed track and the wafer support runs along the carriage's track simultaneously. This enables the wafer support to travel from its fully retracted position (entirely contained in the load lock) to its fully extended position (wafer load/unload position in the processing chamber).

¹ Modular Equipment Standards Committee

3.10.2 Functional Description

The load lock, shown in Fig 3.10, is fabricated from aluminium and incorporates a hinged lid containing a view port. The chamber is pumped by a rotary pump or a turbomolecular pump with the pressure being detected by an appropriate vacuum gauge mounted on the chamber base plate. A pneumatically operated gate valve enables the load lock chamber to be isolated from the processing chamber.

The wafer is transported from the load lock into the processing chamber on a wafer support, which runs on a carriage, which in turn runs on a track.

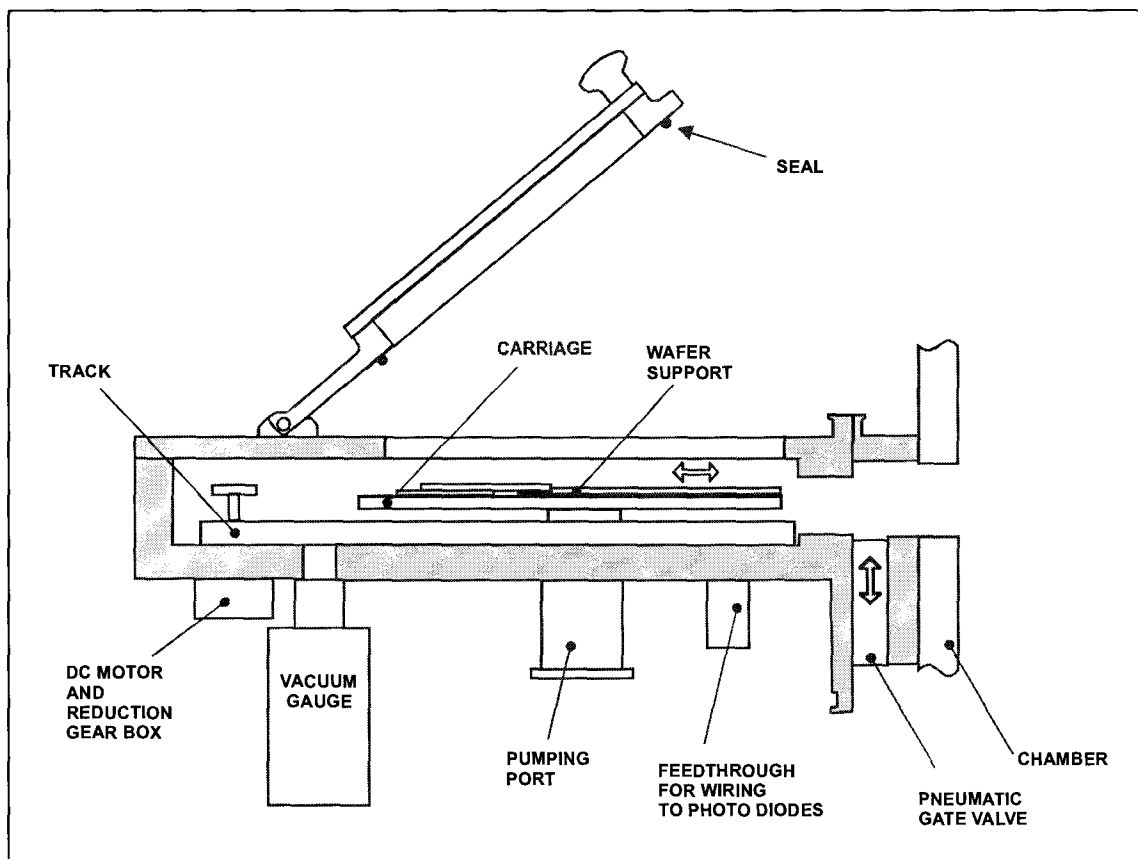

Fig 3.10: Automatic load lock, side view

The wafer transport mechanism, shown in Fig 3.9, comprises the following main components:

- a) A Direct Current (DC) motor and associated reduction gearbox located outside the load lock with the drive shaft entering the load lock through a vacuum seal.
- b) Two steel belts each carried by two pulley wheels.
- c) A track fixed to the load lock baseplate.
- d) A carriage, which runs linearly along the track. The carriage is attached to Steel Belt 1.
- e) A wafer support mounted on the carriage. The wafer support runs linearly along the carriage and is attached to Steel Belt 2.

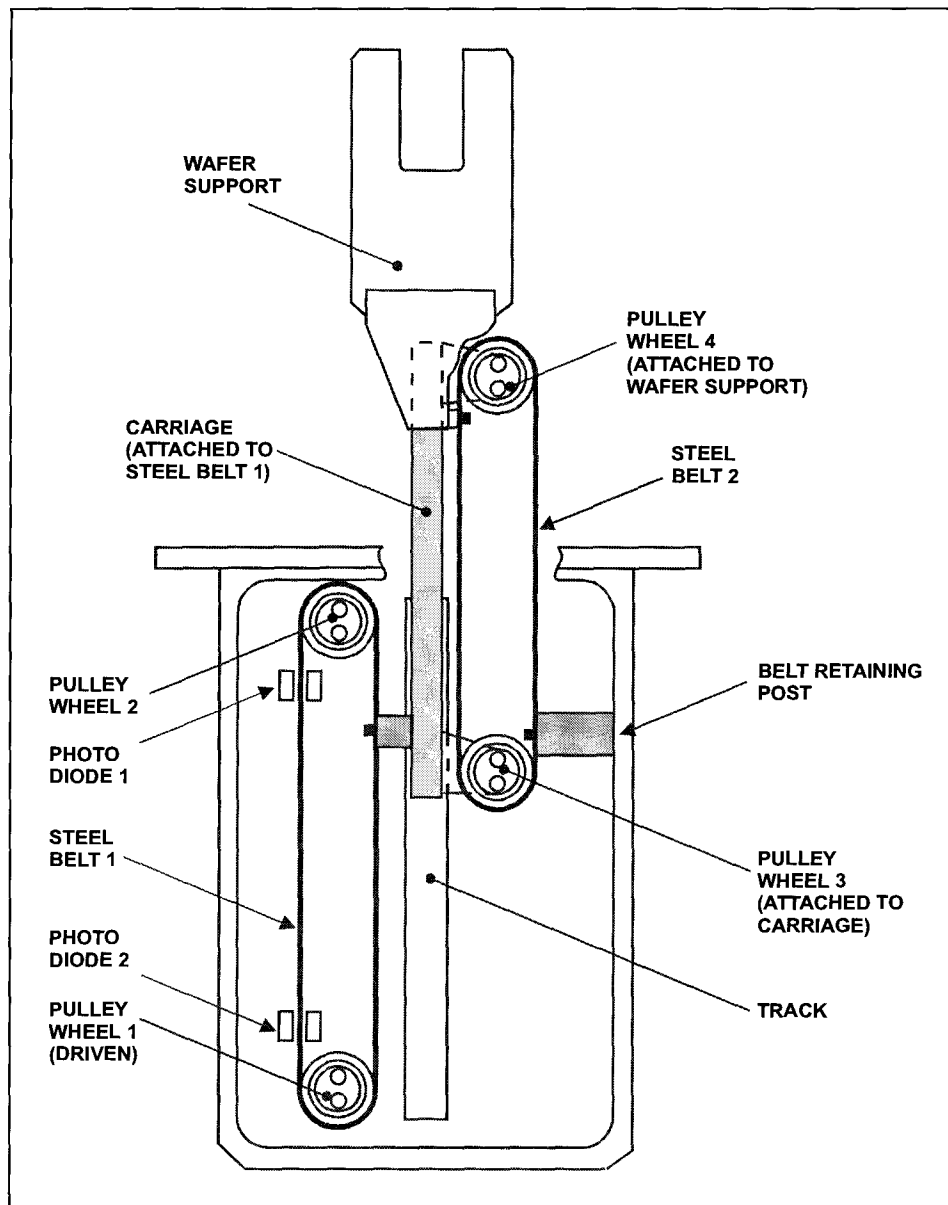

Fig 3.11: Automatic load lock wafer transport mechanism

Before operation, the Wafer Support is fully retracted into the load lock. To load a wafer into the process chamber the following sequence of events occurs:

- 1) The operator opens the load lock door, places the wafer onto the Wafer Support, and then closes the load lock door.
- 2) The load lock chamber is pumped down to base pressure.
- 3) The pneumatically operated gate valve is opened.
- 4) The DC Motor drives Steel Belt 1 via Pulley Wheel 1. Note that Pulley Wheels 1 and 2 are mounted on the load lock baseplate. As Steel Belt 1 is driven, it moves the Carriage, which is attached to it.
- 5) As the carriage travels, it causes Steel Belt 2 to travel around Pulley Wheels 3 and 4. Note that Pulley Wheels 3 and 4 are attached to the carriage and Steel Belt 2 is prevented from moving with respect to the load lock chassis by the retaining post.

As Steel Belt 2 travels with respect to the Carriage, it causes the Wafer Support attached to it to travel along the Carriage.

- 6) As the Wafer Support reaches the end of its travel, a hole in Steel Belt 1 is detected by Photo Diode 2 to stop the DC Motor.
- 7) The wafer is lifted from the wafer support by a wafer lift within the processing chamber, the wafer support is withdrawn from the chamber, and the wafer is lowered onto the processing table by the wafer lift.
- 8) As the Wafer Support reaches its fully retracted position within the load lock, the hole in Steel Belt 1 is detected by Photo Diode 1 to stop the DC motor.
- 9) The gate valve is closed and the load lock can be vented if required.

The above sequence of events is repeated to remove the wafer from the processing chamber.

3.10.3 Wafer support (end effector)

The automatic load lock end effector (wafer support) can accommodate wafer diameters of 3" to 8". See Section 6 (Maintenance) for the end effector wafer size adjustment procedure.

4. Installation and commissioning

4. Installation and commissioning	4-1
4.1 Introduction.....	4-2
4.2 Installing the system.....	4-2
4.2.1 Unpacking.....	4-2
4.2.2 Positioning the system components.....	4-3
4.2.3 Connecting the services.....	4-4
4.3 Commissioning the system.....	4-6
4.4 System adjustments.....	4-6
4.4.1 Heater/Chillers.....	4-6
4.4.2 Process pump purge.....	4-6
Fig 4.1: 3-phase supply cable connections at the power box.....	4-5

4.1 Introduction

The installation and cabling of this system is the responsibility of the customer (unless this has been specifically altered in the sales contract). On completion of the system installation, Oxford Instruments Plasma Technology (OIPT) will commission the system.

4.2 Installing the system

The following instructions are a general guide for installing a typical **Plasmalab**System100 system, supplied with a remote gas pod and rotary vane pump. Customers should be aware of any special requirements for their specific system, e.g. rotary pump purging, hazardous processes, endpoint detectors etc..

For details of the services required, refer to the Installation Data Sheets and the Services Specifications documents included in this manual as Appendices.

IMPORTANT: BEFORE INSTALLING THE SYSTEM, ENSURE THAT ALL PERSONNEL WHO WILL BE INVOLVED HAVE READ AND UNDERSTOOD SECTION 1 'HEALTH AND SAFETY' OF THIS MANUAL.

4.2.1 Unpacking

Unpack system components and check for damage and missing items against the packing list. If any items are damaged or missing, report immediately to the carrier and OIPT.

4.2.2 Positioning the system components



WARNING

LIFTING HEAVY OBJECTS INCORRECTLY CAN CAUSE SEVERE INJURY

When handling heavy system components such as the system unit or vacuum pumps, ensure that the appropriate lifting equipment, operated by fully trained personnel, is used.

When heavy rack-mounted components are handled, ensure that the weight is safely distributed between sufficient personnel.



WARNING

TOPPLING (TIPOVER) HAZARD - SOME SYSTEM COMPONENTS, E.G. ROBOTIC HANDLERS AND AUTOMATIC LOAD LOCKS / TRANSFER CHAMBERS (ESPECIALLY IF FITTED WITH CASSETTE LOAD LOCKS) CAN TOPPLE CAUSING SEVERE INJURY.

When transporting or manoeuvring the system frames, robotic handlers etc., ensure that they remain vertical at all times and use the appropriate lifting / handling equipment.

Ensure that any support frames, supplied with the system, are correctly fitted whenever the system is transported / manoeuvred or dismantled for service / maintenance.

It is entirely the user's responsibility to ensure that all components are supported safely before and during any transporting, manoeuvring or maintenance operations. Support frames provided by Oxford Instruments Plasma Technology are not necessarily adequate for any such operations. The absence of a support frame must not be taken as an indication that no further precautions need to be made before such operations are undertaken.

- 1) Transport the system frames to the clean room, then position them in the required location. Level the system frames (ensuring that the wafer transfer path is aligned from frame to frame) using the adjustable feet, then lock the feet.

OIPT recommends that at least 600mm service access space is allowed between any obstacle (e.g. walls, partitions, etc.) and serviceable items, e.g. the power distribution unit.

- 2) Transport the system PC to the clean room and position it in the required location.
- 3) Transport the gas pod to the grey area and mount it in the required position.

IMPORTANT OIPT gas pods typically weigh >40kg. If you intend fixing your gas pod to a wall, ensure the wall and gas pod fixings are sturdy enough to bear at least four times the weight of the gas pod. Periodically, e.g. annually, check the gas pod and its fixings are secure.

- 4) Transport the rotary vane pump to the grey area and mount it in the required position in accordance with the pump manufacturer's instructions. Refer to the manufacturer's literature in Volume 3 of this manual.

4.2.3 Connecting the services

IMPORTANT NOTES	<p>(A) BEFORE CONNECTING ANY OF THE SERVICES, ENSURE THAT THEY ARE TURNED OFF. E.G. COMPRESSED AIR AND GAS SUPPLY VALVES SET TO THEIR OFF POSITIONS AND ELECTRICAL SUPPLIES SWITCHED OFF AND LOCKED OUT.</p> <p>(B) DO NOT RESTRICT ACCESS TO THE EMERGENCY OFF SWITCH (EMO CONTROL) BY LOCATING CABLES AND OTHER OBSTACLES IN FRONT OF THE SYSTEM.</p> <p>(C) DO NOT LOCATE CABLES WHERE PERSONNEL ARE LIABLE TO WALK. OIPT RECOMMENDS THAT CABLES ARE LOCATED IN CABLE TRUNKING / TRENCHES.</p>
------------------------	--

- 1) Connect the extraction collars on the process chamber(s) (e.g. ICP process chambers) and the gas pod to the appropriate extraction systems.
- 2) Connect the rotary vane pump exhaust line.
- 3) Connect the Nitrogen purge lines to the system services panel(s) and the rotary vane pump.
- 4) Connect the compressed air supply to the system services panel(s) and to the gas pod.
- 5) Connect the gas supplies to the gas pod (all gas supply valves closed).
- 6) Connect the gas outlet line, control cable and earth cable (see Fig 4.1) from the gas pod to the system console.
- 7) Connect the cooling circuits to the system console.
- 8) At the system PC, connect the monitor, keyboard and mouse, then connect the control cable(s) from the PC to the system console.
- 9) Connect the electrical supply from the safety isolation box to the system console. If it is necessary to connect the 3-phase electrical supply cable to the power box, refer to sub-section 4.2.3.1.
- 10) Connect the electrical supply to the PC.
- 11) Ensure that all covers and panels are fitted and attach notices to the system indicating that the system is not ready for service.

Installation is now complete and the system is ready for commissioning by OIPT. Note that customers who have arranged to commission the system themselves can ignore the remainder of this Section.

- 12) Complete and sign the 'System Readiness' form QCF 89 (shipped with the system), then fax it to OIPT who will arrange for the system to be commissioned.

4.2.3.1 Connecting the 3-phase supply cable to the power box

If it is necessary to connect the 3-phase supply cable to the power box, use the following steps.

- 1) Ensure that the supply cable is not connected to the safety isolation box.
- 2) Remove the power box cover.
- 3) Inside the power box, remove the clear plastic safety cover from the power box (secured to the right-hand side of the power box by four screws).
- 4) Connect the 3-phase supply cable wires as shown in Fig 4.1.
- 5) Re-fit the clear plastic safety cover and then the power box cover.

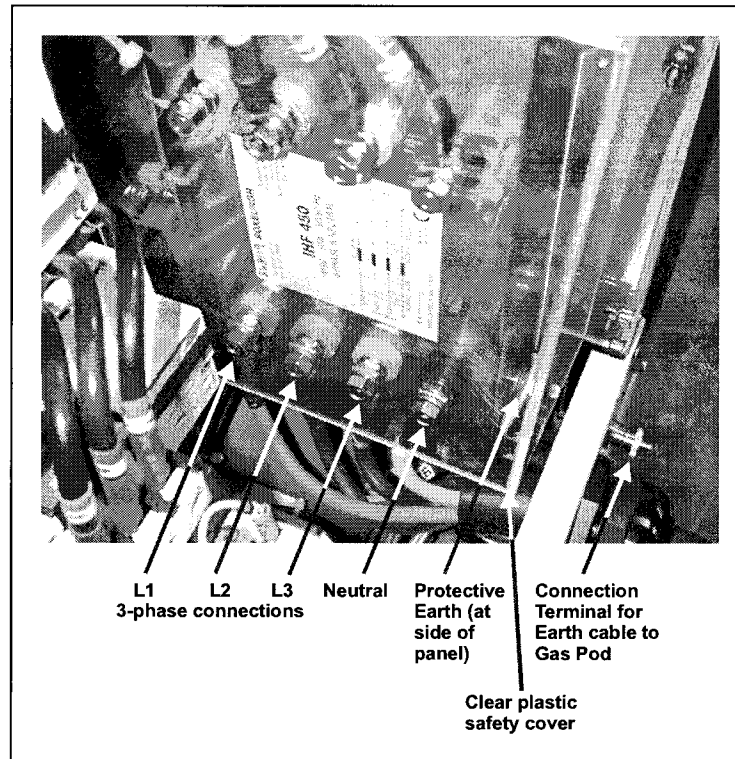

Fig 4.1: 3-phase supply cable connections at the power box

4.3 Commissioning the system

Commissioning of the system will be carried out by OIPT in accordance with their standard procedures and any additional requirements stated in the sales contract. Generally, this will include the following items:

- 1) Checking that the installation has been carried out satisfactorily.
- 2) Powering up the system.
- 3) Checking the operation of the system, including the Emergency Off facility and all interlocks.
- 4) Ensuring that the system can perform the processes specified in the sales contract.
- 5) Providing training on the system.

4.4 System adjustments

This sub-section gives details of adjustments which may be necessary depending on system configuration. In addition to these adjustments, refer to the Operator Adjustments sub-section in Section 5 (Operating Instructions) of this manual.

4.4.1 Heater/Chillers

If your Plasmalab system has a remote Betta-Tech heater/chiller, e.g. CU500, with a Eurotherm Controller, please note the following.

The Eurotherm controller has a default temperature setpoint. For the system to operate correctly, this setpoint must be set to a temperature suitable for the system and coolant used. For example, if the coolant is water, do not set the setpoint to 0° C or below.

Check the setpoint before using the system and if necessary change it in accordance with the instructions given in the Eurotherm Controller's manual.

4.4.2 Process pump purge

An inert gas, normally nitrogen, is added to the process chamber primary mechanical pump for a variety of reasons:

- a) When pumping condensable vapours, it is flowed via the gas ballast port. This helps to prevent condensation during compression, and reduces the amount of liquids such as water vapour or SiCl_4 in the pump fluid.
- b) When pumping reactive gases, it is bubbled through the pump fluid, to help drive out acidic compounds.
- c) When pumping flammable or explosive gases, it is added to dilute the gas below the threshold for explosion.
- d) In dry pumps, the purge gas flow is important for managing heat and limiting particle build up.

WARNING

DILUTION IS NOT USED TO MAKE THE EXHUAST SAFE TO BREATHE: IT MUST STILL BE DUCTED AWAY AND TREATED APPROPRIATELY.

If your Plasmalab system is supplied with a dry pump, e.g. Alcatel ADP122P or ADS602P, that includes its own purge gas monitor, with an output suitable for inclusion in a hardware interlock chain, it is permissible to use this instead of the OIPT purge kit.

If your Plasmalab system is supplied with an oil filled rotary pump, e.g. Alcatel A2063C2, the purge kit supplied is configured for the process gases specified. Note that information about the Rotameters used is given in Appendix R.

For purge requirements not covered by the standard OIPT purge kits or dry pump purge gas monitor an additional purge supplement is included at the end of this section.

Inert pumping

Tools that are pumping only atmospheric gases need no purge, other than any minimum purge the specific pump requires.

Etch tools – halogen gases

Tools that use gases containing halogens (fluorine, chlorine, and bromine – including compounds which contain these elements, e.g. CHF_3), are supplied with purge into the pump, via a rotameter of full scale at least 4 standard litres per minute (slpm).

Etch tools – flammable gases

Certain processes use the flammable gases hydrogen (H_2) and methane (CH_4), often in combination with chlorine (Cl_2) to etch compound semiconductors. The primary pump for these is purged with sufficient gas to bring the exhaust to one third of the lower flammability limit.

A rotameter is used to set and read the flow. A flow switch monitors the purge. The process gases are turned off by means of a hardware interlock if the flow switch reports low flow below 7.5slpm.

Deposition processes – pyrophoric gases

Tools that use silane to deposit thin films containing silicon shall be purged with sufficient gas to bring the exhaust to one third of the lower explosion limit.

A rotameter is used to set and read the flow. A flow switch monitors the purge. For low rate processes (<25sccm SiH_4) the process gases are turned off by means of a hardware interlock if the flow switch reports low flow below 5.2slpm. For high rate processes (<50sccm SiH_4) the process gases are turned off by means of a hardware interlock if the flow switch reports low flow below 10.5slpm.

NOTES:

5. Operating instructions

5. Operating instructions	5-1
5.1 Failure of quartz and alumina components under vacuum.....	5-3
5.2 System power-up.....	5-4
5.3 System shut down and restart.....	5-5
5.3.1 Emergency shut down.....	5-5
5.3.2 Routine shut down.....	5-5
5.3.3 Mains Power failure.....	5-5
5.3.4 Software abort.....	5-5
5.3.5 System shut-down procedure.....	5-6
5.3.6 System restart following an emergency stop, power failure, or software abort.....	5-6
5.3.7 System response to loss of services.....	5-8
5.4 Operator control.....	5-10
5.4.1 Turning screen savers and power saver options off.....	5-10
5.4.2 Logging on.....	5-11
5.4.2.1 Editing users details.....	5-11
5.4.3 System alerts.....	5-14
5.4.4 Pumping down.....	5-15
5.4.5 Automatic process run.....	5-16
5.4.6 Single button automatic process run.....	5-17
5.4.7 Production mode.....	5-18
5.4.8 Manual process run.....	5-19
5.4.9 Venting the system.....	5-20
5.5 Creating and editing recipes.....	5-21
5.5.1 Working with recipe steps.....	5-21
5.5.2 Working with recipes.....	5-22
5.6 Process Datalog.....	5-24
5.6.1 Select Log page.....	5-24
5.6.1.1 Saving a log file as text for use in Microsoft Excel™.....	5-25
5.6.2 Run log page.....	5-28
5.6.3 Leak detection and MFC calibration log page.....	5-29
5.7 Operator adjustments.....	5-30
5.7.1 Manual adjustment of the RF matching unit.....	5-30
5.7.2 Adjusting the nitrogen regulator outlet pressure.....	5-31
5.7.3 Rotary/dry pump N ₂ purge flow rate adjustment.....	5-32
5.8 PC 2000 screens.....	5-33
5.8.1 Pump control page.....	5-33
5.8.2 Robot control page.....	5-36
5.8.3 Recipe page.....	5-37
5.8.4 Production mode page.....	5-39
5.8.5 Chamber 1 process control page.....	5-40
5.8.6 Leak detection page.....	5-45
5.8.7 Mass flow calibration page.....	5-47
5.8.8 Service mode.....	5-48
5.8.8.1 Transferring wafers in service mode.....	5-49
5.8.8.2 Exiting from service mode.....	5-50
5.8.9 System log page.....	5-51
5.9 Log files.....	5-52
Fig 5.1: Menu bar.....	5-10
Fig 5.2: Typical system alert.....	5-14
Fig 5.3: Recipe screen.....	5-21
Fig 5.4: Step Commands pop-up menu.....	5-22
Fig 5.5: Select Log page.....	5-24

Fig 5.6: Run log page.....	5-28
Fig 5.7: Typical leak detection and MFC calibration log page.....	5-29
Fig 5.8: Typical AMU control panel	5-30
Fig 5.9: N ₂ Pressure regulator/gauge	5-31
Fig 5.10: Pump control page	5-33
Fig 5.11: Pump control page vacuum mimic.....	5-34
Fig 5.12: Pump control page operator interface	5-34
Fig 5.13: Robot control page.....	5-36
Fig 5.14: Recipe page.....	5-37
Fig 5.15: Production mode page.....	5-39
Fig 5.16: Chamber 1 process control page	5-40
Fig 5.17: Leak detection page	5-45
Fig 5.18: Mass flow calibration page.....	5-47
Fig 5.19: Service mode page	5-48
Fig 5.20: Wafer transfer in service mode	5-49
Fig 5.21: System log page.....	5-51

WARNING

BEFORE ATTEMPTING TO SWITCH ON (POWER UP OR OPERATE THE SYSTEM), READ AND ENSURE THAT YOU UNDERSTAND SECTION 1 - HEALTH AND SAFETY AT THE BEGINNING OF THIS MANUAL.

5.1 Failure of quartz and alumina components under vacuum

Induction coupled plasma sources contain quartz or alumina tubes or windows under vacuum, which may be subject to attack by the plasma process. If these components fail whilst under vacuum, an implosion can occur. This should not present a safety hazard, provided the equipment is used with all covers and screens in place, but may cause damage to system components.

Failure by implosion becomes more likely as the components age; therefore they should be regarded as consumable items. A programme of regular inspection and renewal of these components is necessary to minimise the risk of implosion.

WARNING

BEFORE POWERING UP THE SOURCE, ENSURE THAT ALL COVERS AND SCREENS ARE FITTED CORRECTLY. DO NOT REMOVE THE COVERS OR SCREENS WHILST THE SOURCE IS UNDER VACUUM.

5.2 System power-up

This sub-section describes the initial power-up (switch on) of the system. It assumes that the system is switched OFF at the wall-mounted safety isolation box.

WARNING

BEFORE POWERING THE SYSTEM UP, CHECK THAT:

- A) THE 'ON-SITE' MAINTENANCE LOG SHOWS THAT THE SYSTEM IS IN A FIT STATE FOR CUSTOMER OPERATION.**
- B) ALL DOORS ARE CLOSED AND ALL COVERS ARE IN PLACE.**
- C) THERE IS NO VISIBLE DAMAGE TO THE SYSTEM.**

CAUTION

Always ensure that any heater/chiller units provided are switched on when the system is powered up.

To power up the system, proceed as follows:

- 1) Ensure that all manually operated cooling water taps are turned ON.
- 2) Check that the 'Slit Valve Lockout' control is unlocked and pushed home.
- 3) Set all Remote/Local switches on the electronics modules to REMOTE.
- 4) Switch ON all the electronics modules located in the console.
- 5) Ensure that the compressed air supply is ON.

CAUTION

If the gas lines may contain air, do not open any gas taps. Continue with the start up procedure, and then use the system to evacuate the lines one at a time. When it is certain that the air has been removed and there are no leaks, open the gas taps.

- 6) If you are certain that the gas lines do not contain air, turn all the manually operated gas taps (on gas cylinders etc.) to ON.
- 7) Check that the Emergency Stop buttons are OUT.
- 8) Set the wall-mounted safety isolation box switch to ON (I).
- 9) Operate SYSTEM ON button (coloured green or with the 'I' legend), located on the console.
- 10) Switch the remote PC operator terminal ON.

5.3 System shut down and restart

The situations, which necessitate system shut down, are given in sub-sections 5.3.1 to 5.3.4.

5.3.1 Emergency shut down

In an emergency, e.g. risk of physical injury, fire, etc., shut the system down by pressing an **Emergency Off** (EMO) button. This will disable all power outputs from the power box (except for low voltage supplies). When any faults have been cleared and the system is safe to operate, restart the system using the procedure given in sub-section 5.3.6.

5.3.2 Routine shut down

When all processing operations are completed and the system is to be shut down for maintenance and repair, use the shut down procedure given in sub-section 5.3.5. On completion of maintenance and/or repair, restart the system using the System power up procedure, given in sub-section 5.2.

5.3.3 Mains Power failure

A mains power failure will halt all system functions. When power is restored, restart the system using the procedure given in sub-section 5.3.6.

5.3.4 Software abort

To halt processing and wafer transfers, click on the **STOP ALL AUTO PROCESSES** button which is displayed at the top of the page on all screens. Clicking on this button will halt the current process and any further wafer transfers. (Any wafer transfers currently in progress will continue.) Also, a Cluster System Abort dialogue is displayed asking you if you wish to shut down the total system. Clicking on **Yes** will:

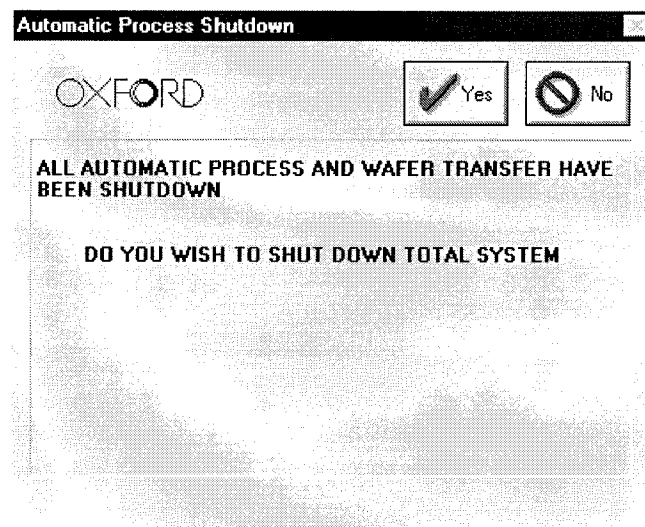

- a) Switch the RF/microwave/magnet power generators OFF.
- b) Switch the pumps OFF.
- c) Close the APC and normally-closed vacuum valves.
- d) Switch the process gases OFF.

As a result of clicking on **Yes**, the system should be restarted using the procedure given in sub-section 5.3.6.

Clicking on the **No** button in the Cluster System Abort dialogue will limit the abort to the actions already done, i.e. stop all automatic recipes. Further processing operations (automatic or manual) can then be carried out after ensuring that the system controller is aware of the current wafer locations.

5.3.5 System shut-down procedure

CAUTION

If your system is fitted with a turbomolecular pump ensure that you read and understand Appendix B before shutting the system down.

This procedure assumes that the process run is finished and that the system is to be shut down for maintenance or repair.

- 1) Ensure that the system has been vented, and all pumps are switched off.
- 2) Exit from the PC 2000 software by clicking on the **System** button, then on the **Exit** option.
- 3) Exit from Windows.
- 4) Turn the PC controller OFF.
- 5) At the Main Console, press the **OFF** button (coloured red or with a '0' legend).
- 6) Switch off and lock off the wall-mounted safety isolation box.
- 7) Turn all manual gas taps on the Main Console, gas pod and compressed gas cylinders **OFF**.
- 8) At the Main Console, set the **SLIT VALVE LOCKOUT** valve to its OFF position (pull the red control knob fully outwards). Fit the adjacent padlock to the slit valve lockout valve's spindle then lock it to prevent any compressed air operated valve movement.
- 9) Turn off the compressed air supply.
- 10) Ensure that all heated components have cooled to ambient temperature, then turn off the cooling water.

WARNING

PART OF THE SYSTEM IS ELECTRICALLY ENERGISED IF THE CUSTOMER'S SUPPLY IS TURNED ON. UNLIT INDICATOR LAMPS DO NOT MEAN THAT IT IS SAFE TO WORK ON THE SYSTEM.

5.3.6 System restart following an emergency stop, power failure, or software abort

A power failure, or emergency stop will halt all system functions. A software abort, (by clicking on the **STOP ALL AUTO PROCESSES** button, then clicking on **Yes** in the Cluster System Abort dialogue), also halts the machine quickly.

When power is restored, and it is safe to turn on or restart the system, use the following procedure:

- 1) Turn off the machine at the system power off switch.
- 2) Turn on the machine at the system power on switch. (If a robot arm is fitted, it should move slowly to its home position.)
- 3) Turn off the machine at the system power off switch again (see following Note A).
- 4) Turn on the machine at the system power on switch. (If cassette load lock(s) are fitted, their elevators will move to find the end positions.)
- 5) A user with access to the Service Mode can then use the facilities to add wafers to the mimic page so that the system controller knows where any wafers are.

- NOTES:**
- A) The double on and off routine (in Steps 3 and 4) is essential only for a system with a Hine robot arm and vacuum cassettes. If the arm has stopped inside the cassette and both are initialised together, then both the arm and the cassette contents will be damaged. Therefore the Hine arm will go to its home position when power is applied, but the cassettes will initialise ONLY if the Hine arm is already at home position when power is applied.
 - B) System and data log files may have been corrupted. Refer to subsection 5.9 (page 5-52) for details.

5.3.7 System response to loss of services

This sub-section briefly describes the system's response to the loss of services.

Electrical

Process and pumps stop. Air operated gas and vacuum valves shut. Where the chamber APC function and main chamber vacuum valve are combined in one unit, it is automatically closed on loss of electrical power. Load lock wafer transfer valve(s) retain their current state, or finish their current transition. A Hine arm robot will finish its current movement. Other wafer transfer devices stop moving immediately. Information on the current process and wafer position is lost.

Loss of one of three phases: rotary vacuum pump stops. If the phase powering the process controller remains live then the process aborts, all valves shut but the system controller retains information on the current state of the machine. If the process controller phase is lost, then current information is lost.

Compressed air

All air operated gas inlet and vacuum valves shut. (Exceptions: air-operated valves with electrical solenoids unaffected; normally open gas interlock valves open). Gas flows stop and the chamber is not pumped. Process power(s) are turned off as soon as a flow or pressure exceeds a tolerance band - normally within 5 seconds. Load lock wafer transfer valve(s) go to an undefined state. Rotational movement of the air operated 4-way load lock stops.

Cooling water

Certain components are protected by a water flow switch. If the flow is low, a warning message is displayed on the PC, and the associated device is turned off.

Leybold dry pumps have their own internal over-temperature switches. Loss of flow for these pumps will eventually cause a temperature trip causing a process abort (process chamber pump) and the relevant pump to be switched off. Devices such as turbo pumps have their own internal protection against overheating and are not protected by external flow switches.

Turbomolecular pump nitrogen purge

A flow meter monitors the nitrogen purge flow rate downstream of the purge flow regulator. Low pressure (< 50 sccm) will cause the process to be aborted, all gas and vacuum valves to shut and PC 2000 will display the alert shown below.

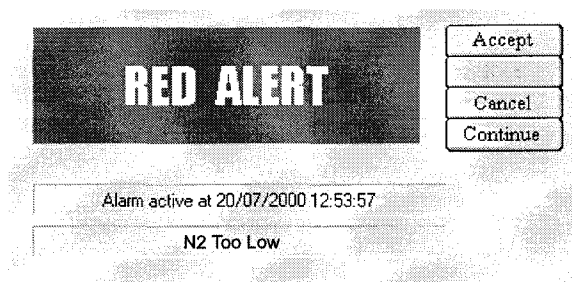

Process gases

Loss of process gas is detected when a mass flow controller goes out of tolerance during process. The active process devices (normally plasma power) are paused, and gas flows remain active. The process will resume automatically if gas is restored.

Vacuum pumps

An auxiliary circuit on the pump contactor detects pump failure due to overload or short circuit, and the process gases are immediately halted.

If a rotary vane or dry vacuum pump stops pumping for other reasons during a process, e.g. if it fails or its power is disconnected, and the vacuum interlock switch's contacts remain closed, process gas will continue to flow into the process chamber. Gas flow will stop when the chamber pressure exceeds the vacuum switch trip level of 600 mbar absolute. The front-end software will show the interlock status as 'fault'.

WARNING

DISCONNECTING THE POWER TO AUXILIARY EQUIPMENT, ESPECIALLY VACUUM PUMPS, WHILE RUNNING A PROCESS CAN CAUSE A HAZARD IN THE PROCESS CHAMBER.

ENSURE THAT THE SYSTEM IS SHUT DOWN USING THE PROCEDURE GIVEN IN SUBSECTION 5.3.5 BEFORE DISCONNECTING ANY POWER CABLES FROM THE POWER BOX, OR SWITCHING OFF ANY ELECTRICAL SUPPLIES TO AUXILIARY EQUIPMENT.

WARNING

IF THE EQUIPMENT HALTS DURING PROCESS BECAUSE THE VACUUM SWITCH HAS OPENED, THERE MAY BE A SERIOUS GAS HAZARD IN THE CHAMBER AND PUMPING LINES.

ASSESS THE RISKS BEFORE TRYING TO PUMP OR VENT THE CHAMBER.

PERSONAL PROTECTIVE EQUIPMENT MAY BE NECESSARY.

5.4 Operator control

The PC 2000 facilities are accessed from the menu bar at the top of the screen as shown in Fig 5.1.

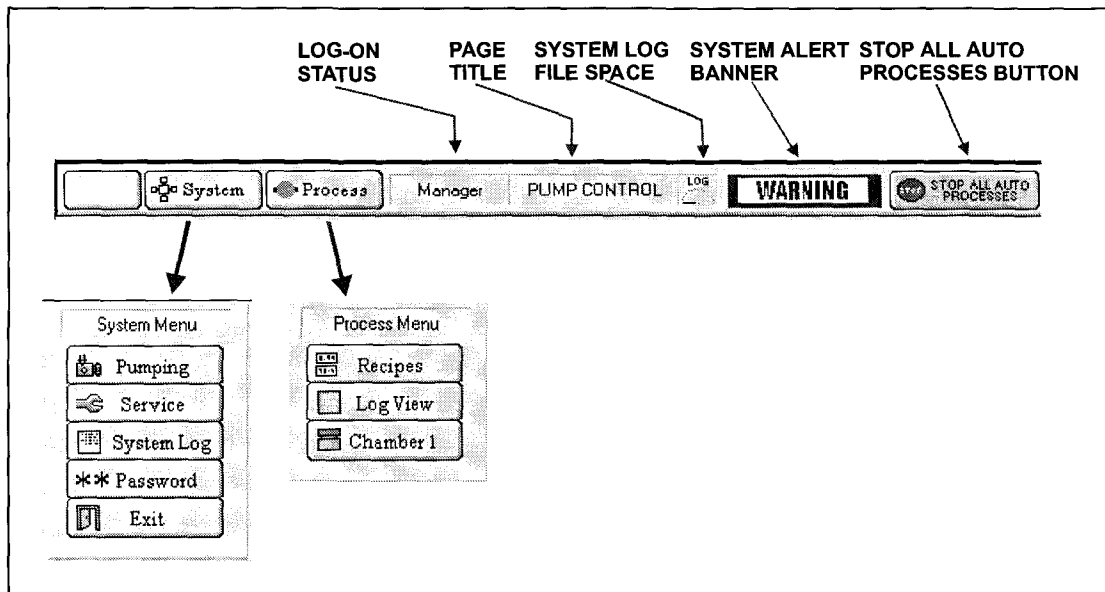

Fig 5.1: Menu bar

This system incorporates an ICP 180 processing station, and an automatic single-wafer load lock chamber. Refer to sub-section 5.8, page 5-33 for diagrams and brief descriptions of the screens/pages.

5.4.1 Turning screen savers and power saver options off

CAUTION

When running the PC 2000 software, using a Screen Saver or allowing the PC to enter any of the Power Saver modes can cause the PC to lose communications with the PLC.

Before starting the PC 2000 software, ensure that Screen Savers and all Power Saver options are turned off. A procedure to do this is given in the following text.

Use the following procedure to turn the screen savers and power saver options off. Note that this procedure is applicable to Microsoft Windows XP™; for other versions of Windows, refer to the on-line help.

- 1) Right-click anywhere in a clear area on the Windows desktop and then, on the displayed menu, select the **Properties** option. The Display Properties dialogue box is displayed.
- 2) Select the **Screen Saver** tab.
- 3) In the Screen Saver drop-down list, select the **(None)** option.
- 4) Click on the **OK** button.

- 5) On the taskbar, select the **Start** button, then the **Settings** option, then select **Control Panel**. The control panel is displayed.
- 6) Select **Power Options**. The Power Options Properties dialogue is displayed.
- 7) Ensure that all power scheme options are set to '**Never**'. If necessary, use the drop-down lists to select the '**Never**' option.
- 8) Click on the **OK** button.
- 9) Close the control panel.

5.4.2 Logging on

To log on to the PC 2000 software, proceed as follows:

- 1) Select the PC 2000 icon . The PC 2000 splash screen is loaded, and then the Access Control dialogue is displayed:

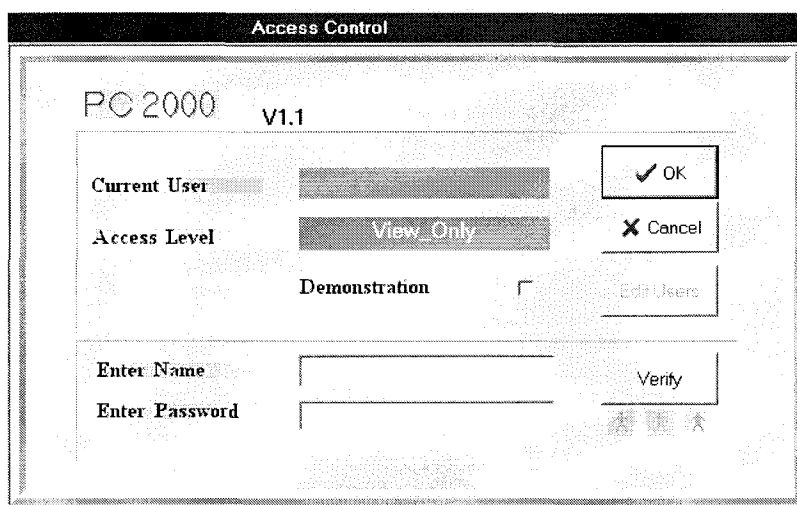

- 2) Enter your name and password in the appropriate data fields (note that data entry in the Password field is case sensitive), and then select the **Verify** button. If you make a mistake in entering your name and password, select the **Verify** button and then re-enter the data. After verification of the entered data, your log-on status is displayed in the **Current User** and **Access level** fields.
- 3) Select the **OK** button. The PC 2000 software continues to load, and then the Pump Control page is displayed.

5.4.2.1 Editing users details

Users details, i.e. names, passwords and facility access options can be edited by a person logged on as a Manager. To do this, use the following steps:

- 1) Log on as a Manager (see sub-section 5.4.2).
- 2) Select the **System** Menu, and then the **Password** option. The Access Control dialogue box is displayed.

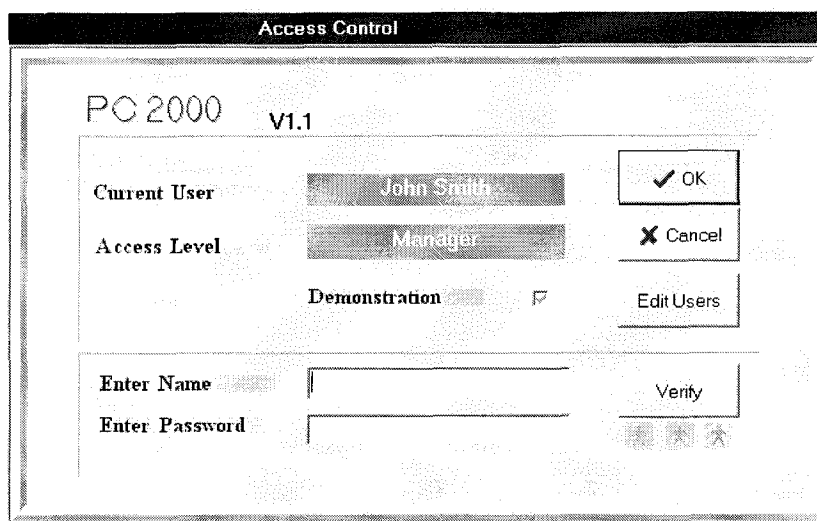

- 3) Select the **Edit Users** button. The Edit User List is displayed.

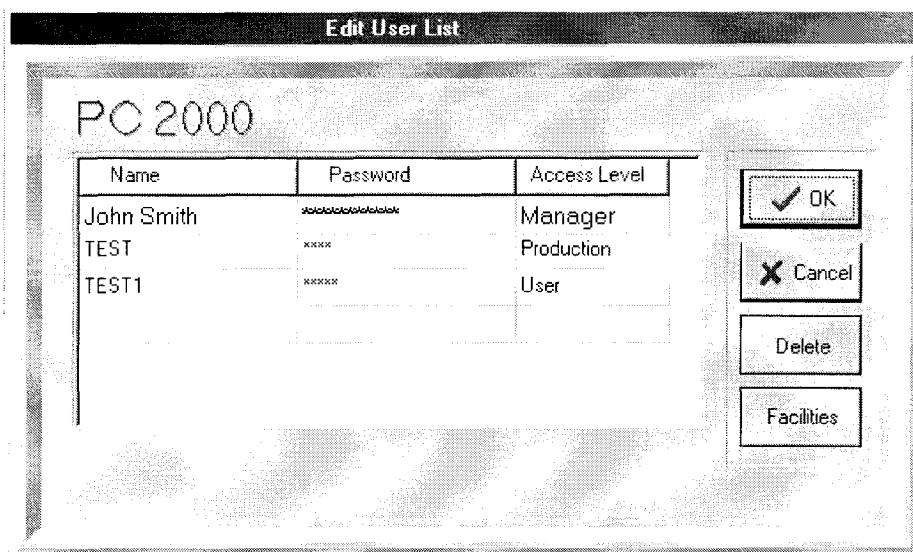

- 4) To add a new user, click on the Name and Password cells then enter the required details (remember that text entered into the Password cell is case sensitive). Clicking on the Access Level cell will display a scrollable drop-down list with the following options:

Option	Result
Quit	Exit from the drop-down list.
View_Only	All Facilities automatically disabled.
User	A set of Facilities can be selected, see Step 5.
Production	See sub-section 5.4.7 (page 5-18).
Maintenance	A special set of Facilities is automatically enabled. Note that this access level has its own recipes and steps for maintenance and does not allow access to process recipes and steps, or allow the system log to be viewed.
Manager	All Facilities automatically enabled.

Select one of the access levels for the new user.

Similarly, existing Names, Passwords and Access Levels can be edited. In addition, existing entries can be removed from the list by selecting a name and then selecting the **Delete** button.

- 5) The Facilities enabled for 'User' (selected in Step 4) can be edited by selecting the Facilities button while the cursor is in the name field for that user. This will display the Edit User Facilities dialogue box.

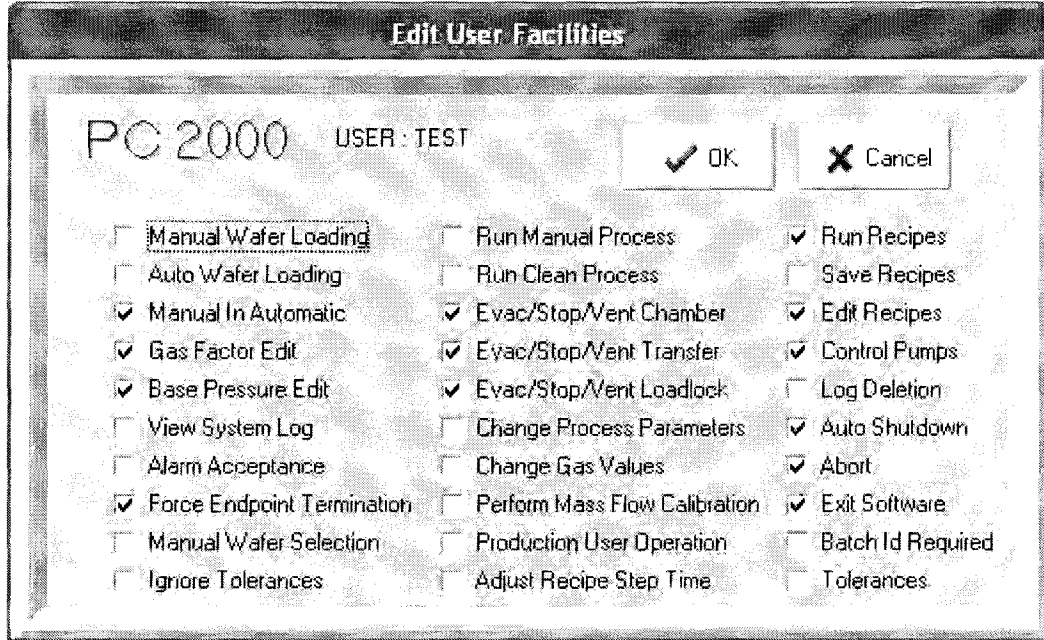

WARNING

BEFORE ENABLING FACILITIES, CONSIDER CAREFULLY WHICH FACILITIES WILL BE SELECTED FOR THE PERSON USING THE 'LOG ON' NAME. FOR EXAMPLE, ALLOWING AN INEXPERIENCED USER ACCESS TO THE 'TOLERANCES' PAGE WOULD ALLOW THE USER TO CHANGE TOLERANCES WHICH COULD POSSIBLY RESULT IN SYSTEM MALFUNCTION AND EXPOSE THE OPERATOR TO HAZARDOUS SITUATIONS.

- 6) Click on the appropriate checkboxes to enable the facilities available to the selected name (✓ indicates enabled). Click on the **OK** button to accept the entered data and exit.

Note that the enabled facilities are dependent on the name and not on the access level, e.g. two people logged on as users can have different sets of facilities enabled.

5.4.3 System alerts

System alerts are displayed when PC 2000 detects an event that requires the attention of the user. Each alert is automatically categorised depending on the nature of the event and the response required by the user. The category of the event can range from a warning indicating that a service parameter is out of tolerance to a process abort indicating that a process setpoint has been out of tolerance for so long that the process cannot be completed. A typical system alert is shown in Fig 5.2.

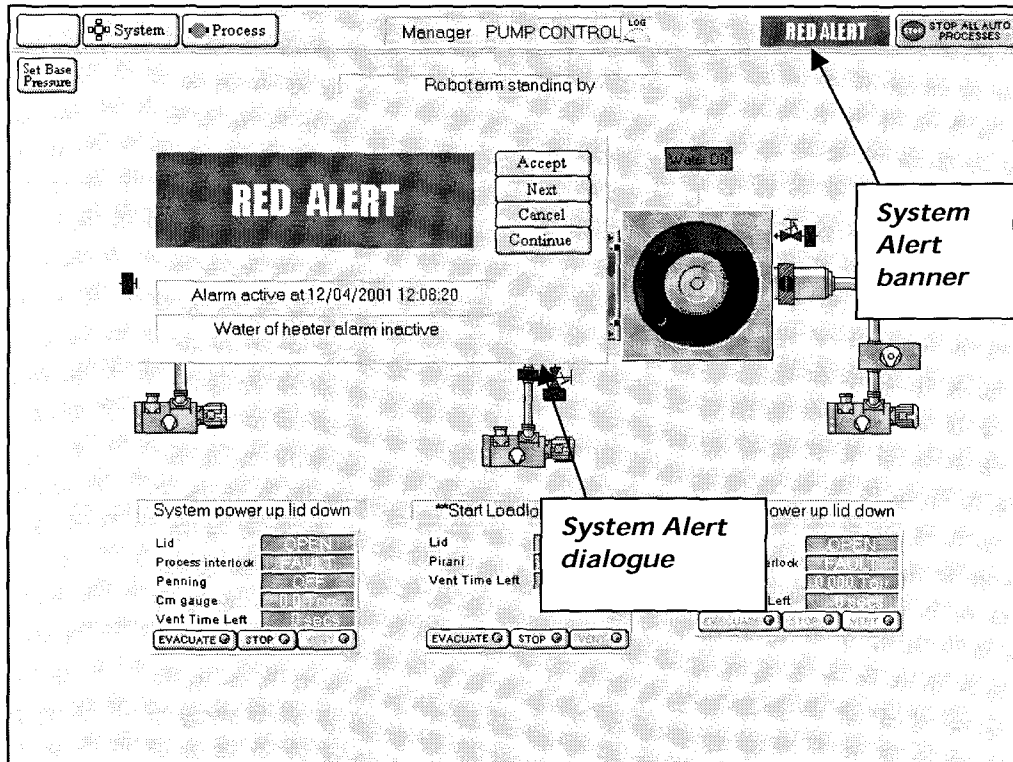

Fig 5.2: Typical system alert

The alert is displayed as a banner in the menu bar at the top of the screen with an associated dialogue in the main screen area. Note that more than one alert can be active at the same time, each requiring action by the user in turn.

There are three categories of alert indicated by the colour and text displayed in the banner and dialogue:

- Blue** Warning e.g. water flow low.
- Yellow** Hazard – not currently used.
- Red** Process abort, e.g. high-reflected RF power.

A user logged on at any access level can close the alert dialogue, but only a user logged on as a system manager can clear the alert banner from the menu bar. The dialogue options are:

- Accept** button: System Managers only. Clear the alert and log it.
- Next** button: View the next alert.
- Cancel** button: System Manager only. Clear the alert; do not log it.

Continue button: Close the alert dialogue box – the alert banner remains displayed on the menu bar.

Note that option buttons that are not available (i.e. **Accept** and **Cancel** due to user 'logged on' status and **Next** when there is only one active alert) are greyed out.

The alert message usually contains an adequate description of the detected event. If it is a service fault (water flow, purge gas etc.) then verify that the service is available to the machine as soon as possible. Depending on the nature of the service, the system may allow the machine to continue to operate, so that the current process can be completed. Do not start a new process before checking the service.

The red alerts are often due to a process setpoint being out of tolerance for too long. In these cases, the process is halted by the system. If it is authorised to resume processing with a parameter deviation then:

- 1) Check the most recent process log to find the process time remaining.
- 2) Construct a new process with a modified process time and check the 'Ignore tolerance' option. Note that this removes all tolerance checking. The machine should be monitored by an operator for further deviations when operated in this condition.

5.4.4 Pumping down

- 1) On the Pump Control page, select the **SET BASE PRESSURE** button, then enter the required process chamber base pressure if different from the default.
- 2) Ensure that the Automatic load lock/transfer chamber's lid is closed. (Automatic load lock/transfer chamber lid open/closed status is shown in the panel adjacent to the mimic).
- 3) Click on each dry pump/rotary vane pump mimic to start the pump.
- 4) Select the **Evacuate** button for the process chamber. The relevant valves will operate and the process chamber will be pumped down.
- 5) Select the Evacuate button for the Automatic load lock. You will be prompted to enter a wafer identity - either enter the identity and click **OK**, or click **Cancel** (to pump down without a wafer in the Automatic load lock). The relevant valves will operate and the Automatic load lock will be pumped down.

NOTE: Turning off any rotary vane pump will cause all process and pumping actions using that pump to stop.

- 6) To achieve a low base pressure in the system, pump for at least 12 hours. Where chambers or process heaters are part of the system, raise the temperatures of these near their maximum values for the first six hours of pumping to assist out-gassing, then return the temperature to ambient.

WARNING

PARTS OF THE EQUIPMENT MAY BE TOO HOT TO TOUCH DURING CHAMBER HEATING.

5.4.5 Automatic process run

An automatic process run as described in this sub-section can be carried out by a user logged on as a Manager. See sub-section 5.4.6, page 5-17 for details of a single button automatic process run, which can be carried out by any user.

- 1) Insert the wafer into the Automatic load lock. (If necessary, vent the Automatic load lock by selecting the **STOP** button then the **VENT** button).
- 2) Close the Automatic load lock's lid.
- 3) Select the relevant **EVACUATE** button. A dialogue box will be displayed allowing entry of a Wafer Identity, if any.
- 4) Check that the system has pumped down to base pressure. (The process chamber message panel should display 'Base Pressure reached'.)
- 5) Ensure that the Automatic load lock is at the required pressure. (Check the relevant panel on the Pump Control page). Green 'ready for transfer' indicators (◀▶) are displayed on each chamber mimic when it is available for vacuum transfer.
- 6) Select the Process menu, then the Recipe option. Click on the **Load** button then select the required recipe.
- 7) Click on the **Run** button. This will start wafer transfers and wafer processing.

NOTES:

- a) You can pause the process at any time by selecting the **PAUSE** button. This will cause the Step Time and the plasma power to stop with the current step time indicated. Re-starting the process will cause the process to continue from the time it was paused. If, during the pause period, you change any of the process parameters, e.g. gas demand, pressure etc., you must press the **START** button for the changes made to come into effect, this will cause the step timer to continue from the time it was paused.
- b) You can stop the process at any time; the message 'Process Complete' will be displayed, if required, you can then run the same or another process.

WARNING

CONTACT WITH TOXIC GASES CAN CAUSE DEATH OR SERIOUS INJURY.

WHERE ANY PROCESS GAS IS TOXIC, DO NOT TRANSFER A WAFER FROM THE PROCESS CHAMBER TO THE LOAD LOCK UNTIL ALL PROCESS GAS HAS BEEN PUMPED OUT.

ENSURE THAT THE AUTOMATIC VENT SEQUENCE IS ALLOWED TO COMPLETE.

IF THESE PRECAUTIONS ARE NOT CARRIED OUT, THERE COULD BE A HAZARD IN THE LOAD LOCK.

- 8) When the 'Process Complete' message is displayed, select the Pump Control page and move the wafer from the process chamber to the Automatic load lock using the same method as the transfer in.
- 9) Open the Automatic load lock's lid and remove the wafer.
- 10) If required, the system can now be vented, see sub-section 5.4.9 page 5-20.

5.4.6 Single button automatic process run

A single button automatic process run allows a complete process to be run automatically. The run starts by pumping the system down, carrying out the process and then venting the system. The automatic process run can be carried out by a user logged on at any access level, e.g. Manager, User etc..

Before starting an automatic process run, the rotary vane/roots/dry pumps must be started. It is suggested that once the system is powered up, the Manager logs on, starts the pumps, evacuates the process chamber and then re-logs on for the User or Production Operator to carry out the automatic process run(s).

When the pumps have started and the User or Production Operator is logged on, carry out the automatic process run using the following steps.

- 1) Insert the wafer into the Automatic load lock. (If necessary, vent the Automatic load lock by selecting the **STOP** button then the **VENT** button).
- 2) Close the Automatic load lock's lid.
- 3) In PC 2000, select the System menu and then the Recipe option. The Recipe page is displayed.
- 4) Load the required recipe.
- 5) Select the **Run** button. You will be prompted enter a wafer identity; enter the wafer identity and select the **OK** button. The following sequence will be automatically carried out:
 - i) The automatic load lock will start to evacuate and the Process page is displayed.
 - ii) When the automatic load lock reaches base pressure, the wafer will be transferred into the process chamber.
 - iii) When the wafer has been transferred into the process chamber, the recipe will start.
 - iv) When all of the process steps have completed, the Pump Control page is displayed, the wafer will be transferred into the automatic load lock and then the automatic load lock will vent.
- 6) When the vent sequence is completed, open the automatic load lock's lid and remove the wafer.

To process another wafer, repeat the above steps from Step 1). If running the same recipe, Step 4 can be skipped otherwise load another recipe.

NOTES:

- a) You can pause the process at any time by selecting the **PAUSE** button. This will cause the Step Time and the plasma power to stop with the current step time indicated. Re-starting the process will cause the process to continue from the time it was paused. If, during the pause period, you change any of the process parameters, e.g. gas demand, pressure etc., you must press the **START** button for the changes made to come into effect, this will cause the step timer to continue from the time it was paused.
- b) You can stop the process at any time; the message 'Process Complete' will be displayed, if required, you can then run the same or another process.

5.4.7 Production mode

The production mode facility is provided to make operation of the system as simple as possible. In this mode, the user is provided with a 'special' Recipe page, which allows the user to load and run a recipe and then vent the automatic load lock.

To carry out production mode processing, use the following steps:

- 1) Log on as a Manager.
- 2) Start the external rotary vane pump/dry pumps for the process chamber and automatic load lock.
- 3) Evacuate the process chamber. Do not evacuate the automatic load lock at this stage.
- 4) Select the system menu, and then select the Passwords option.
- 5) Log on using the appropriate user name and password for the production mode. The Production mode page is displayed. See sub-section 5.8.4, page 5-39.
- 6) Open the automatic load lock's lid and place the wafer to be processed on the transfer arm. Close the lid.
- 7) Select the **Load** button, then select the required recipe from the displayed list and select the **OK** button.
- 8) Enter a batch identity.
- 9) Select the **Run** button. The automatic load lock will automatically pump down and the recipe will run. Note that this button only becomes active when a recipe has been loaded and a batch identity has been entered, and the associated indicators are coloured green.
- 10) When the 'Process Complete' message is displayed, select the **System** menu and then the **Pumping** option to vent the automatic load lock.
- 11) When the automatic load lock has finished venting, open its lid and then remove the processed wafer.
- 12) You can now carry out a further process by repeating steps 6) to 11). If running the same recipe Step 7) can be skipped, otherwise load another recipe.
- 13) On completion of production mode processing, log on as a Manager.

5.4.8 Manual process run

- 1) Insert the wafer into the Automatic load lock. (If necessary, vent the Automatic load lock by selecting the **STOP** button then the **VENT** button).
- 2) Close the Automatic load lock lid.
- 3) Select the Automatic load lock's **EVACUATE** button. A dialogue box will be displayed allowing entry of a Wafer Name, if any.
- 4) Check that the system has pumped down to base pressure. (The process chamber message panel should display 'Base Pressure reached').
- 5) Select the Process menu, then the Chamber 1 option. Set the parameters as required, e.g. Step Time, RF generator power, chiller temperature, chamber pressure, and gas demands.
- 6) Ensure that the Automatic load lock is at the required pressure. (Check the relevant panels on the Pump Control page). Green 'ready for transfer' indicators (◀▶) are displayed on each chamber mimic when it is available for vacuum transfer.
- 7) On the Pump Control page, click on the Automatic load lock wafer mimic. The Robot Control page is displayed (see Fig 5.13, page 5-36).
- 8) Click on the Process Chamber wafer mimic. The wafer is transferred from the Automatic load lock into the Process Chamber.
- 9) On the Chamber 1 process page, check that the set parameters are correct for your required process.
- 10) Click the **START** button. (Note that if this button is not active, the chamber has not reached base pressure.) The process will commence.

NOTES:

- a) You can pause the process at any time by selecting the **PAUSE** button. This will cause the Step Time and the plasma power to stop with the current step time indicated. Re-starting the process will cause the process to continue from the time it was paused. If, during the pause period, you change any of the process parameters, e.g. gas demand, pressure etc., you must press the **START** button for the changes made to come into effect, this will cause the step timer to continue from the time it was paused.
- b) You can stop the process at any time; the message 'Process Complete' will be displayed, if required, you can then run the same or another process.

WARNING

CONTACT WITH TOXIC GASES CAN CAUSE DEATH OR SERIOUS INJURY.

WHERE ANY PROCESS GAS IS TOXIC, DO NOT TRANSFER A WAFER FROM THE PROCESS CHAMBER TO THE LOAD LOCK UNTIL ALL PROCESS GAS HAS BEEN PUMPED OUT.

ENSURE THAT THE AUTOMATIC VENT SEQUENCE IS ALLOWED TO COMPLETE.

IF THESE PRECAUTIONS ARE NOT CARRIED OUT, THERE COULD BE A HAZARD IN THE LOAD LOCK.

- 11) When the 'Process Complete' message is displayed, select the Pump Control page and move the wafer from the process chamber to the Automatic load lock using the same method as the transfer in.
- 12) Open the Automatic load lock's lid and remove the wafer.
- 13) If required, the system can now be vented, see sub-section 5.4.9 page 5-20.

5.4.9 Venting the system

WARNING

CONTACT WITH TOXIC GASES CAN CAUSE DEATH OR SERIOUS INJURY.

BEFORE VENTING THE PROCESS CHAMBER, ALWAYS ENSURE THAT THE SYSTEM IS ADEQUATELY PURGED AND PUMPED.

Do not vent a system which has used toxic gases unless the system has been adequately pumped first.

For example: Gases having Threshold Limit Values (TLVs) of 1ppm or below, e.g. Chlorine, require at least 20 minutes pumping before venting.

After venting, there may still be residual gases in the process chamber. Consider wearing suitable personal protection, e.g. a respirator.

To vent the system, use the following steps.

- 1) From the System menu, select the Pumping option.
- 2) On the Pump Control page, select the **STOP** button then the **VENT** button for each chamber. Note that the vent sequence is controlled by a timer to allow time for the turbo pumps to 'spin' down.
- 3) When all of the 'Vent Time Left' timers have decremented to zero, all of the pumps have been switched off automatically, and the complete system has been vented.

Do not attempt to open the process chamber lid until the vacuum switch has changed status, i.e. to its high-pressure status (In this condition, on the Pump Control page the vacuum status field will display 'FAULT').

5.5 Creating and editing recipes

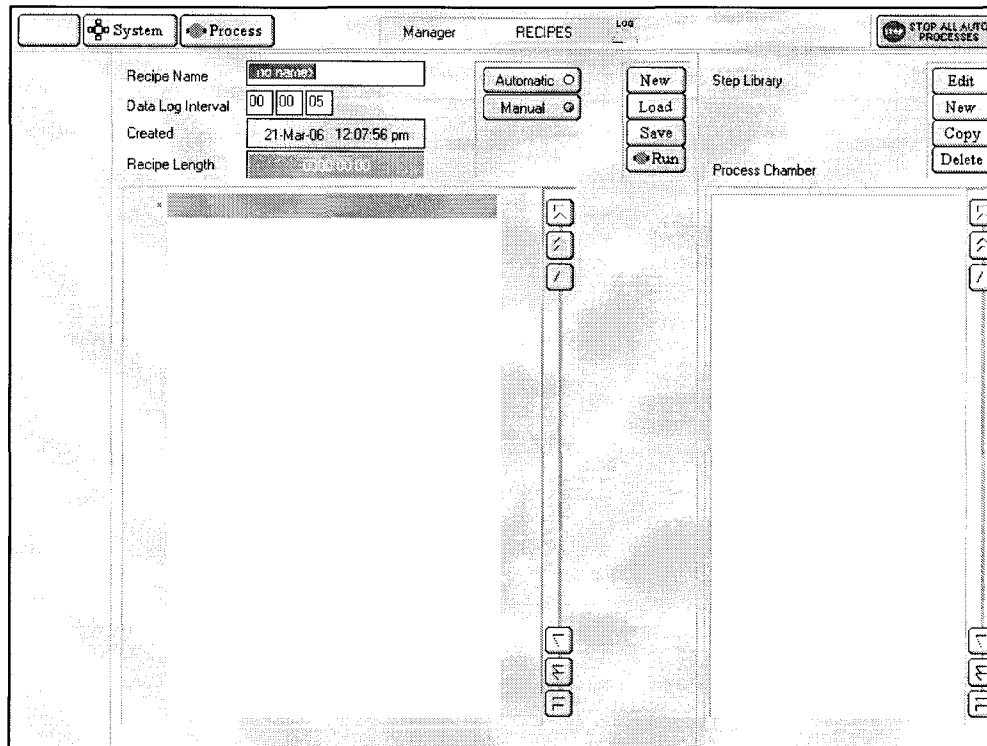

Fig 5.3: Recipe screen

This page is used to assemble and store in memory all the set points and instructions which make up a Recipe for an Automatic Mode run. These recipes consist of a sequence of process Steps. 'Drag and Drop' facilities are provided to copy library steps into a recipe.

NOTE: For a description of the facilities on this page, refer to sub-section 5.8.3, page 5-37.

The **Recipe** option (accessed from the **PROCESS** button) displays the recipe page for the process chamber. This page allows you to create / edit recipes and the recipe steps that they contain.

NOTE: Before creating / editing recipes, make sure that you understand the operation of key components of the system to ensure that recipes proceed as expected.

A recipe is created by adding steps from the **Step Library** to the Recipe Step Name fields. The recipe is then allocated a Data Log Interval and saved.

5.5.1 Working with recipe steps

Recipe steps are stored in the **Step Library** list. The list can contain any number of steps, depending on available hard disk space. When the displayed list is full, it becomes scrollable to allow you to view all of the list contents.

CREATE A NEW RECIPE STEP

To create a new recipe step, use the following procedure:

- 1) In the Step Library panel, select the **NEW** button. The Step Edit page is displayed.
- 2) Enter the step parameters as required, then click on **OK**. The step is automatically saved.

To create a recipe step, based on an existing recipe step, use the following procedure:

- 1) Select a recipe step from the **Step Library** list, i.e. click on it to highlight it.
- 2) Select the **COPY** button. Enter a new step name.
- 3) Edit the step parameters as required, then click on **OK**. The new recipe step is automatically saved.

EDIT AN EXISTING RECIPE STEP

To edit an existing recipe, use the following procedure:

- 1) Select a recipe step from the **Step Library** list, i.e. click on it to highlight it.
- 2) In the Step Library panel, click on the **Edit** button.
- 3) Edit the step's process parameters as required, then click on **OK**. The step is automatically saved.

NOTE: Changing an existing recipe step will not alter saved recipes, which use the old version of that step.

DELETE A RECIPE STEP

To delete a recipe step, use the following procedure:

- 1) Select the recipe step from the **Step Library** list, i.e. click on it to highlight it.
- 2) Select the **DELETE** button; the selected recipe step is deleted.

5.5.2 Working with recipes

Recipes are 'built' using existing recipe steps, and edited as required.

Within a recipe, steps can be manipulated using the **Step Commands** pop-up menu (accessed by clicking on the Recipe Steps field).

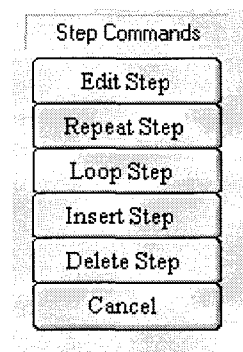

Fig 5.4: Step Commands pop-up menu

The **Step Commands** pop-up menu provides the following options:

Edit Step Enables the selected (highlighted) step to be edited.

- Repeat Step** Repeats all subsequent steps until a Loop Step is reached. This group of steps can be repeated any number of times. (When you select this option, you are prompted to enter the number of times the group of steps is to be repeated.)
- Loop Step** Terminates a Repeat Step group.
- Insert Step** Creates a 'gap' above the selected step to allow another step to be dragged into the list.
- Delete Step** Deletes the selected step from the list.
- Cancel** Closes the **Step Commands** pop-up menu.

BUILD A RECIPE

To build a recipe, use the following procedure:

- 1) In the Recipe panel, select the **NEW** button.
- 2) Click on a recipe step in the **Step Library** list, hold the left mouse button down then drag the mouse pointer to the **Step Name** field next to the asterisk (*) then release the mouse button. The step name is displayed in the **Step Name** field.
- 3) Repeat 2) as required to add further steps to the recipe. Note that once you have filled the Step Name field, the recipe step list becomes scrollable, enabling you to add a maximum total of 1000 steps.
- 4) To remove a step from the list, click on it to highlight it then select the **Delete step** button from the **Step Commands** pop-up menu. Any further steps will move up the list by one place.
- 5) To add a step before an existing step, click on the existing step then select the **Insert step** button from **Step Commands** pop-up menu. The selected step and all those following it will move down the list by one place. You can then drag another step from the **Step Library** list into the now vacant field.
- 6) When all steps have been added, enter a time into the **Data Log Interval** field, then enter a name for the recipe in the **Recipe Name** field. Finally, select the **SAVE** button.

EDIT A RECIPE

To edit a recipe, use the following procedure:

- 1) Select the **LOAD** button, then select the recipe to be edited.
- 2) In the Step Commands pop-up menu, click on the Edit Step button, then edit the process parameters as required. Note that editing a recipe step will not affect the associated step, i.e. a step having the same filename, in the Library of Available Steps.
- 3) To remove a step from the list, click on it to highlight it then select the **DELETE STEP** button from the **Step Commands** pop-up menu. Any further steps will move up the list by one place.
- 4) To add a step before an existing step, click on the existing step then select the **INSERT STEP** button. The selected step and all those following it will move down the list by one place. You can then drag another step from the **Step Library** list into the now vacant field.

5.6 Process Datalog

All processes are automatically data-logged. The interval between logging events is set in the Recipe screen.

The Process Datalog facility allows you to view process data runs and associated comments. The facility comprises three pages:

- SELECT LOG page – allows you to select the process data to view.
- RUN LOG page – lists the selected process data, for all runs except Leak detection runs and MFC calibration runs, with respect to time.
- Leak detection and MFC calibration log page – displays the Leak detection runs and MFC calibration runs in text and graphical formats.

These pages are described in the following text.

5.6.1 Select Log page

The Select Log page is displayed by selecting the **Process** button, then the **Log View** option.

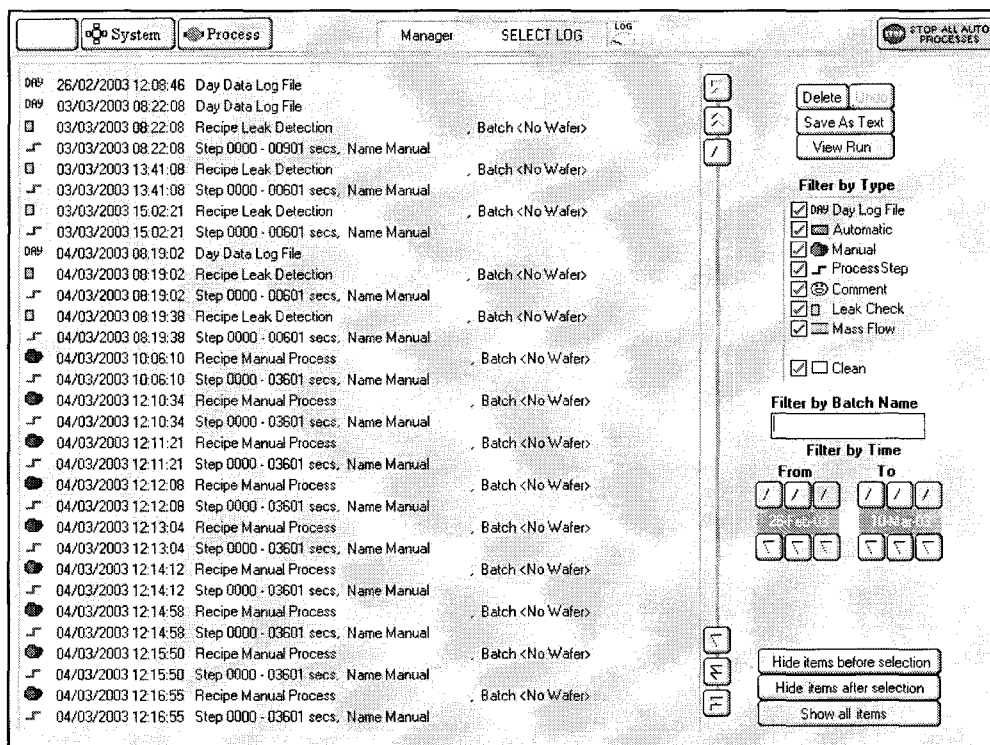

Fig 5.5: Select Log page

The page comprises a list of logged events, which can be filtered by type, batch name and time. When the required events have been selected, they can be viewed on a Log View page.

The facilities provided on the page are as follows:

List of logged events	Displays a list of logged events in a date/time sequence. Each event is identified by an icon, date, time, title, duration, name and comments (if present). An event is selected (highlighted) by clicking on it.
Delete button	Deletes the selected event
Undo button	Undo the last action
Save As Text button	Save the selected event as a text file for use in spreadsheets etc.
View Run button	Opens either the Run Log page (see sub-section 5.6.2, page 5-28) or, if either a Leak detection run (🔍) or MFC calibration run (🔧) is selected, the Leak Detect and MFC calibration log page (see sub-section 5.6.3, page 5-29) with the selected log data displayed.
Filter by Type list	A list of event types with associated checkboxes. Use this panel to select the events to display in the Event list. A checkbox showing an 'x' indicates that the associated event type will not be displayed. A checkbox showing a '✓' indicates that the associated event type will be displayed.
Filter by Batch Name field	Enter a batch name to list only logged events associated with that batch.
Filter by time fields and buttons	Use these controls to select events occurring in a time range to be displayed.
Hide items before selection button	Displays all events after and including the highlighted event.
Hide items after selection button	Displays all events before and including the highlighted event.
Show all items button	Displays all previously hidden events.

5.6.1.1 Saving a log file as text for use in Microsoft Excel™

NOTE: OIPT now supplies customers with comprehensive software to view/analyse PC 2000 log files. The software, LogViewer, is provided on the system PC. For full details of LogViewer, refer to its Manual by following the shortcut on the desktop of your system PC.

Any logged process run can be saved as text and then opened in Excel for viewing, analysing, etc. To do this, use the following steps:

- 1) On the Select Log page, select the required process run (any multiple steps will be automatically highlighted).

- 2) Select the **Save As Text** button. The **Save As** dialogue is displayed.
- 3) Navigate to the target location for the log text file, enter a filename and in the 'Save as type:' field select 'Log Text Files (*.Txt)' from the drop-down list. If saving to a floppy disk, label it and insert into the drive now.
- 4) Select the **Save** button. The text file is saved in your chosen location.
- 5) Start Excel and then in the File menu, select the Open option. The 'Open' dialogue is displayed.
- 6) Navigate to the location of the saved text file and in the 'Files of type:' field, select 'All Files (*.*)' from the drop-down list. Select the required text file and then select the **Open** button. The 'Text Import Wizard – Step 1 of 3' dialogue is displayed:

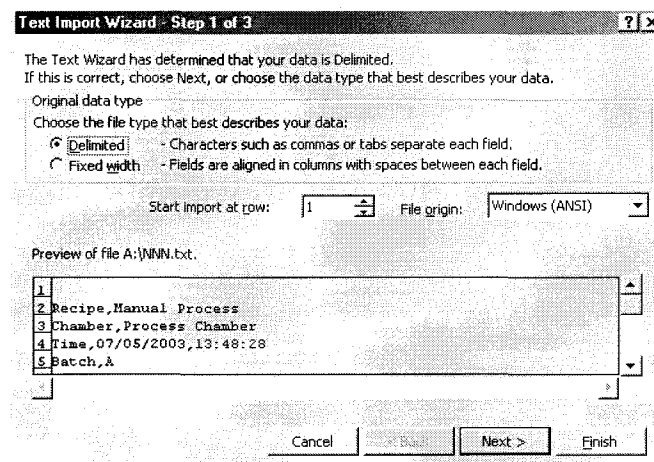

- 7) In the 'Original data type' panel, select the 'Delimited' option and then select the **Next >** button. The 'Text Import Wizard – Step 2 of 3' dialogue is displayed:

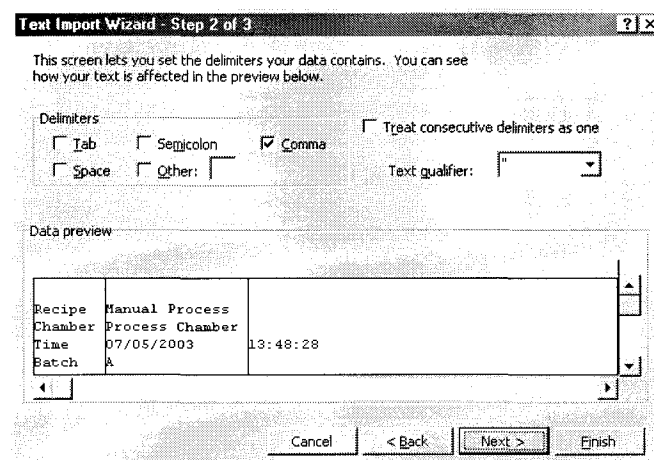

- 8) In the 'Delimiters' panel, select the 'Comma' checkbox. Select the **Next >** button. The 'Text Import Wizard – Step 3 of 3' dialogue is displayed:

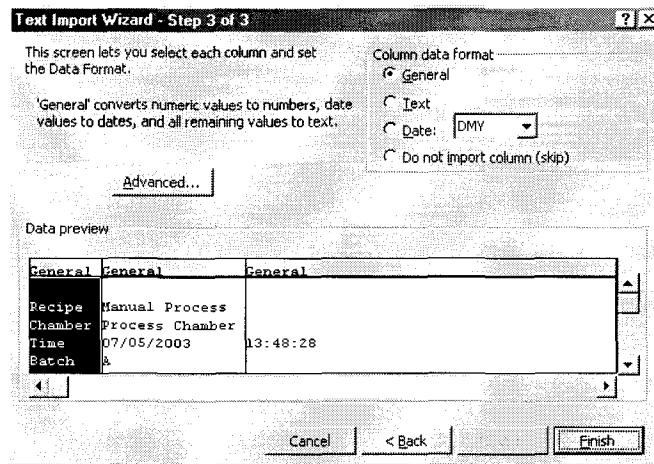

- 9) In the 'Column data format' panel, ensure that the 'General' option is selected and then select the **Finish** button. The process run log data is now displayed in the Excel worksheet.
- 10) Adjust the column widths so that all text is visible and then save the spreadsheet.

5.6.2 Run log page

The Run Log page is accessed from the Select Run page by clicking on the **View Run** button with any process run other than a leak detection run (□) or MFC calibration run (▣) selected.

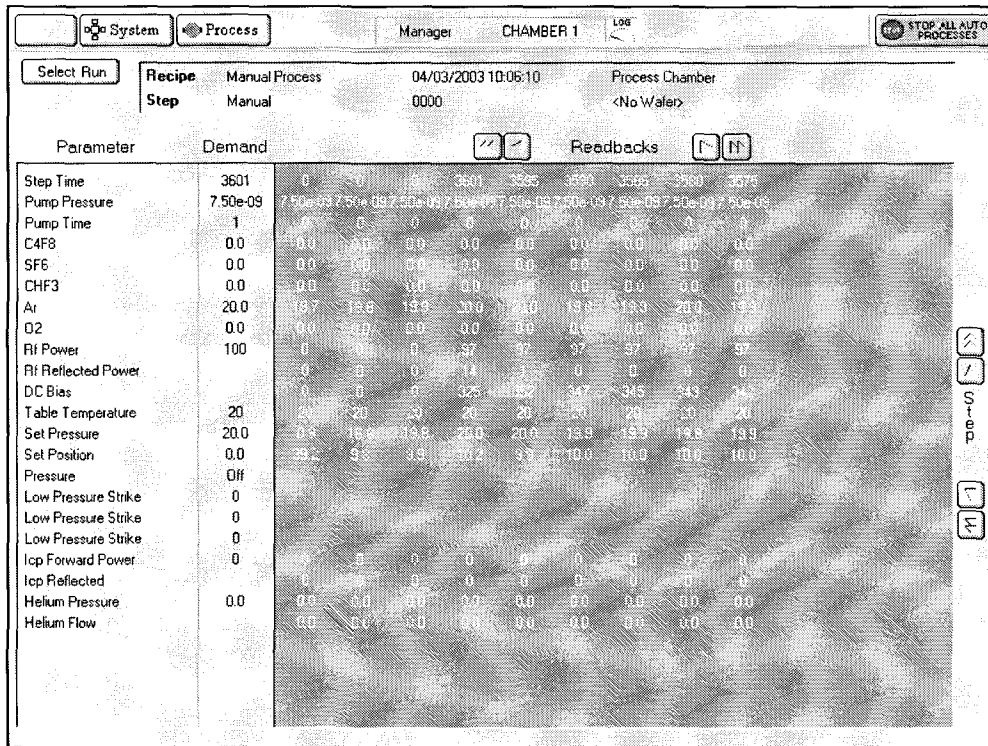

Fig 5.6: Run log page

The page displays the Parameters, Demands and Readbacks for the selected log data.

The facilities provided on the page are as follows:

- Select Run** button Displays the Select Log page.
- Log information panel Displays details about the selected log data.
- Parameter** list Lists the logged parameter names
- Demand** list Displays the demanded parameter value
- Readbacks** list Displays the logged parameter values with respect to time at the log intervals specified for the process run. The list can be scrolled horizontally either by single readbacks or by page. The list can also be scrolled vertically to display further steps (for multi-step recipes).

5.6.3 Leak detection and MFC calibration log page

The leak detection and MFC calibration log page is accessed from the Select Run page by selecting either a leak detection run () or MFC calibration run () and then clicking on the **View Run** button.

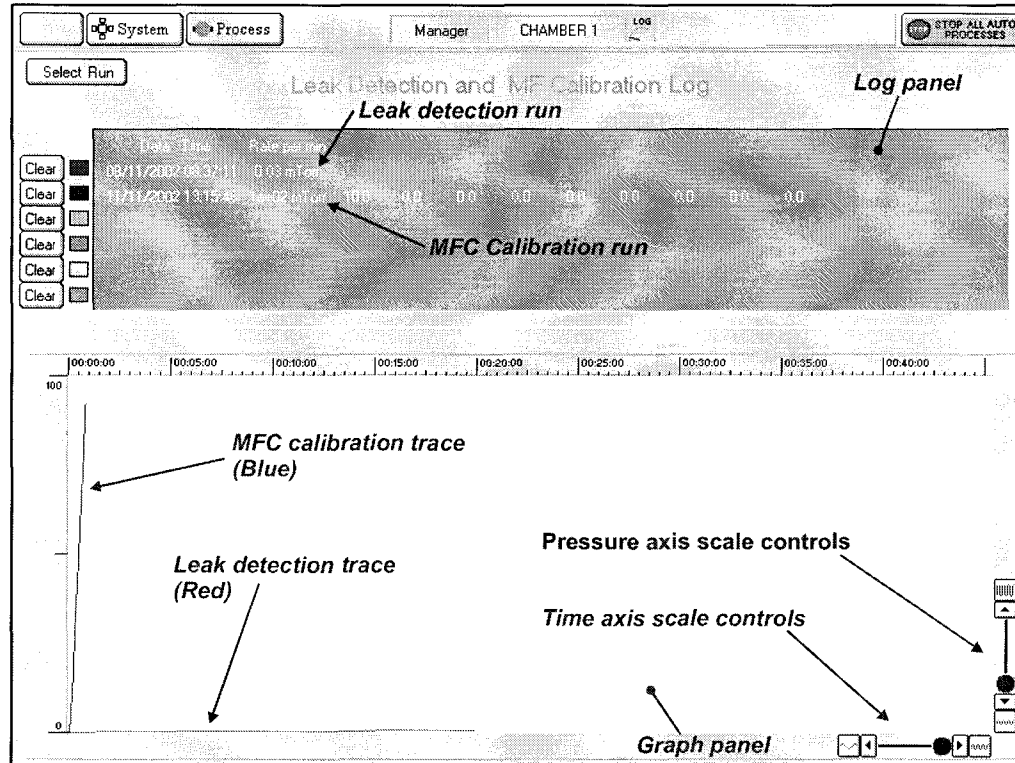

Fig 5.7: Typical leak detection and MFC calibration log page

This page is used to view details of up to six leak check runs and/or MFC calibration runs. Note that Fig 5.7 shows details of a leak test (red trace) and an MFC calibration run (blue trace).

The facilities available on this page are:

Select Run button	Displays the Select Run page.
Clear buttons	Select to remove the associated data from the log panel and graph panel. Note that to re-display the cleared data, you must return to the Select Run page and re-select it.
Log panel	Displays details of each run in text format.
Graph panel	Displays a plot of each run (pressure versus time). Each run is represented by a coloured trace as indicated by the palette displayed adjacent to the run data in the Log panel. The graph can be scaled in each axis by the controls located at the bottom-left corner of the graph.

5.7 Operator adjustments

5.7.1 Manual adjustment of the RF matching unit

A manual adjustment panel, shown in Fig 5.8, is located behind a flap in the front of the equipment rack. It comprises the following controls and indicators:

- Auto / Manual switch: Sets the operating mode of the RF matching unit.
- C1 MAX / MIN: Manual adjustment of RF matching capacitor C1. (Rotating its shaft clockwise or counter clockwise.)
- C2 MAX / MIN: Manual adjustment of RF matching capacitor C2. (Rotating its shaft clockwise or counter clockwise.)
- C1 PARK: Park position potentiometer for C1.
- C2 PARK: Park position potentiometer for C2.
- RF Interlock ON/OFF: Disables the RF interlock. RF generators deliver no power if the interlock is off.

Capacitor positions for C1 and C2 are displayed as numbers from 000 (minimum) to 999 (maximum).

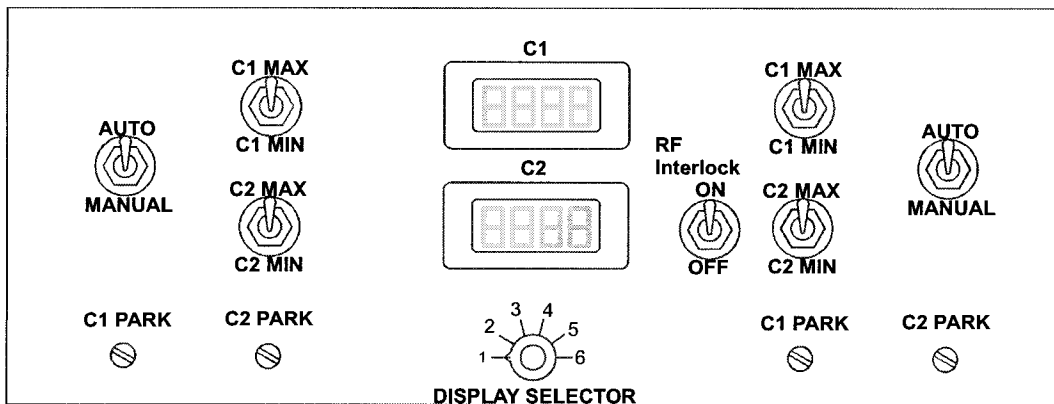

Fig 5.8: Typical AMU control panel

Note that Fig 5.8 shows an AMU control panel with control facilities for two AMUs. The left-hand side controls are for AMU1 and the right-hand side controls are for AMU2. The LCD displays are switched using the DISPLAY SELECTOR switch as shown in the following table.

DISPLAY SELECTOR POSITION	LCD 1 (UPPER)	LCD 2 (LOWER)
1	AMU 1 C1 POSITION	AMU 1 C2 POSITION
2	RF 1 FORWARD POWER	RF 1 REFLECTED POWER
3	RF 1 SETPOINT	RF 1 Hi/Lo
4	RF 2 FORWARD POWER	RF 2 REFLECTED POWER
5	RF 2 SETPOINT	SPARE
6	AMU 2 C1 POSITION	AMU 2 C2 POSITION

For full details of the Oxford Instruments Plasma Technology AMU, refer to its Operation and Maintenance manual in Volume 3 of this manual.

5.7.2 Adjusting the nitrogen regulator outlet pressure

NOTE: Refer to Section 2 for a description of the Nitrogen vent distribution circuit.

The regulator outlet pressure should not usually require adjustment from its factory setting. However, if adjustment is necessary, proceed as follows.

WARNING

THIS PROCEDURE INVOLVES WORKING ON THE SYSTEM WITH COVERS REMOVED AND WITH THE ELECTRICAL POWER ON. THEREFORE IT MUST ONLY BE CARRIED OUT BY TRAINED AND COMPETENT PERSONNEL WHO ARE AWARE OF THE RISKS INVOLVED.

- 1) Remove system panels as necessary to gain access to the regulator.

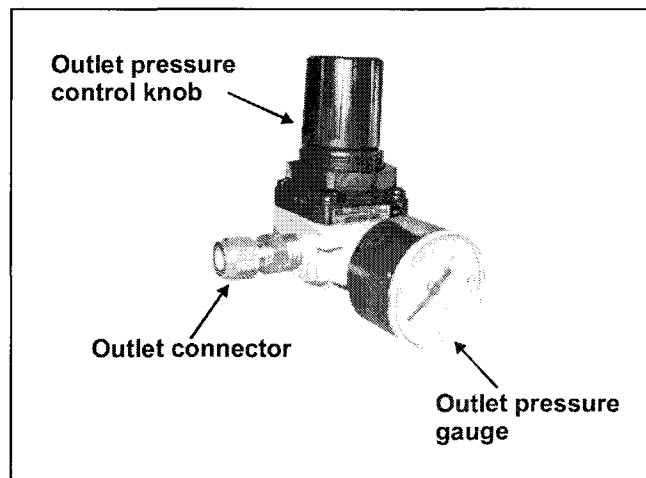

Fig 5.9: N₂ Pressure regulator/gauge

- 2) Adjust the regulator outlet pressure control knob to set the outlet pressure to the maximum which will not open the check valve; normally 0.5 to 0.7 bar gauge as indicated on the regulator gauge.

NOTE: Setting the outlet pressure too low will extend system venting times excessively, and may compromise the purge gas flow to the turbo pump if fitted. Setting the outlet pressure too high will open the check valve and waste gas, but will not reduce venting times.

- 3) Refit all system covers.
- 4) Carry out a simple process to check that the vent sequence operates correctly.

5.7.3 Rotary/dry pump N₂ purge flow rate adjustment

CAUTION

If the rotary/dry pump's N₂ purge flow rate is inadequate, damage to the pump could occur.

Ensure that the flow rate is set to the value recommended by the pump manufacturer.

The rotary/dry pump's N₂ purge flow rate is set at the factory before system shipment and should not need adjustment. However, the pump purge rate will need to be confirmed on installation and at any time the purge gas supply pressure changes significantly. If adjustment is necessary, refer to Appendix R in this manual.

5.8 PC 2000 screens

5.8.1 Pump control page

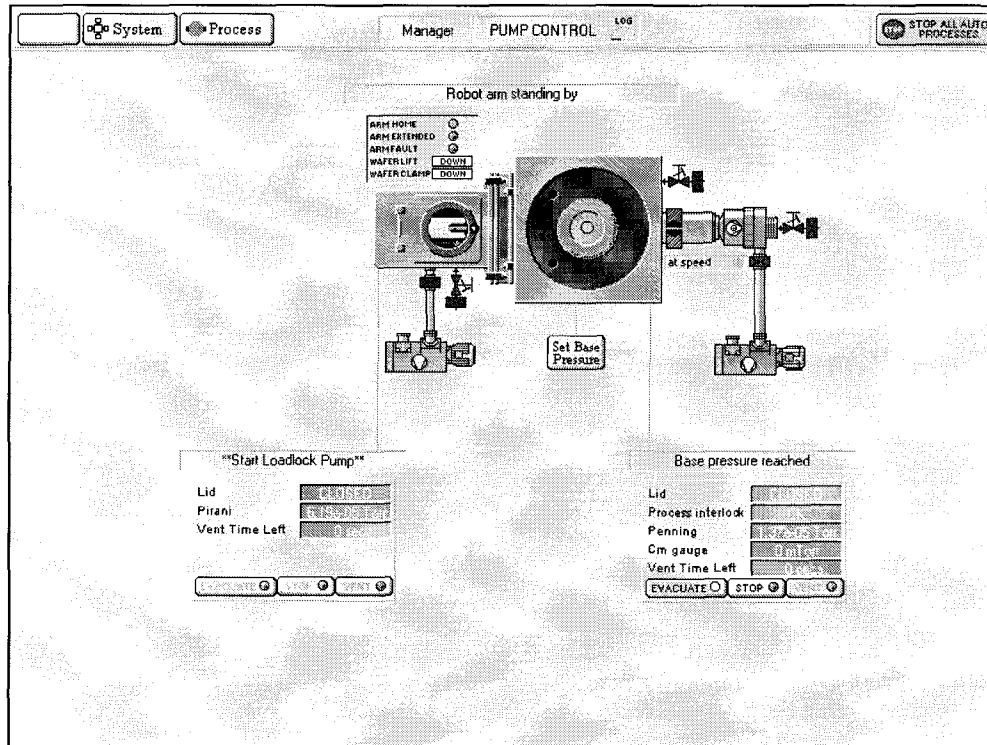

Fig 5.10: Pump control page

The pump control page provides control and monitoring of the vacuum system. The page has the following features:

Vacuum system mimic

The vacuum system mimic is shown in Fig 5.11. Each chamber contains a wafer indicator which when coloured green indicates that a wafer is present in the chamber. Clicking on a green wafer indicator will display the Robot Control page showing the possible wafer destination.

Note that the Automatic Pressure Controller (APC) mimic displays the current status of the valve, i.e. open, closed, mid position or fault (indicated by a red dot).

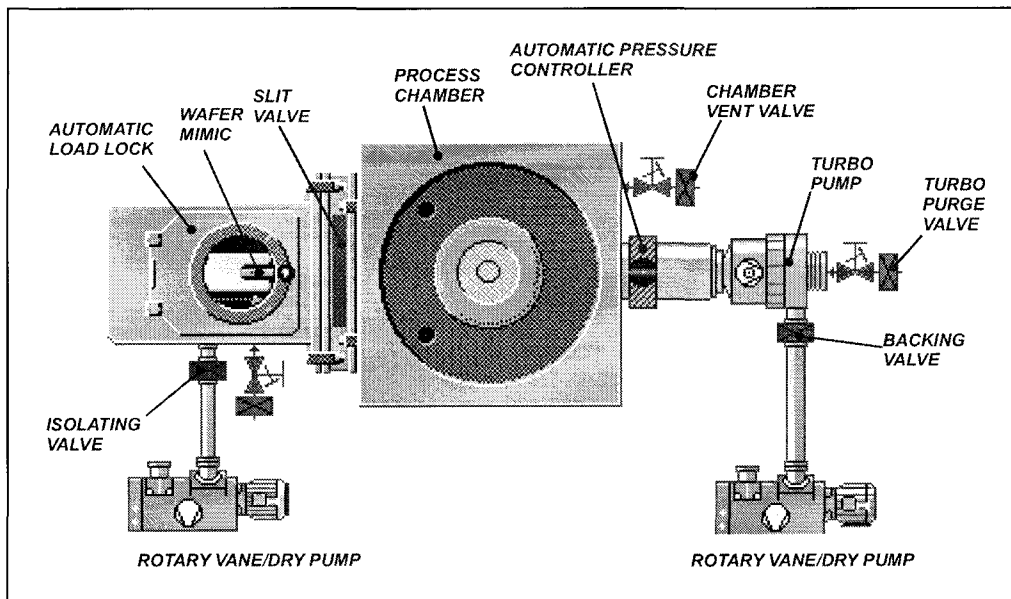

Fig 5.11: Pump control page vacuum mimic

Operator interface

The operator interface facilities are labelled in Fig 5.12.

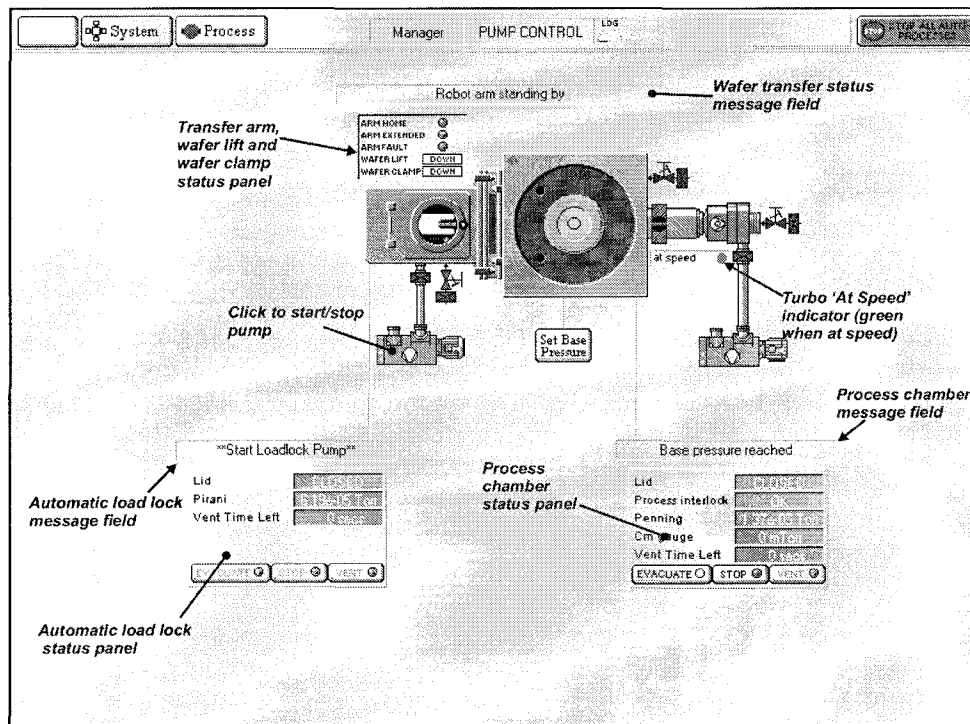

Fig 5.12: Pump control page operator interface

The following controls are provided:

- a) Control and status panels for the process chamber and Automatic load lock. Each Control and status panel has associated EVACUATE, STOP and VENT buttons.
 - i) **EVACUATE** buttons: Select to pump-down the associated chamber.

- ii) **STOP** buttons: Select to stop either pumping down or venting the associated chamber. Note that the **STOP** button must be selected before venting to ensure the correct sequencing of the valves.
- iii) **VENT** buttons: Select to vent the associated chamber.
- b) Mimics of all valves showing open/closed status (coloured green when open, red when closed).
- c) Rotary/dry pump controls. Clicking on a rotary vane/dry pump mimic button will switch the associated pump on or off (a running rotary pump is indicated by animation).
- d) Transfer arm, Wafer lift and Wafer clamp status panel. Displays indicators for ARM HOME, ARM EXTENDED and ARM FAULT (illuminated when active). Also displays WAFER LIFT and WAFER CLAMP status (up, down, moving or fault). See the following table.

Message	Meaning
UP	The UP microswitch is detected as active.
DOWN	The DOWN microswitch is detected as active.
MOVING	Both microswitches are detected as inactive.
FAULT	Both microswitches are detected as active.

- e) The run status of the turbo pump is indicated by an associated message panel containing an indicator. While the turbo pump is running up to speed, the message 'accelerating' is displayed and the indicator is flashing yellow. While the turbo pump is at its operating speed, the message 'at speed' is displayed and the indicator is green.
- f) A SET BASE PRESSURE button. Select to set the Process Chamber Base Pressure.
- g) Context related message panels for the process chamber, Automatic load lock and wafer transfer progress.
- h) 'Ready for transfer' indicators (◀▶) - displayed when the associated chamber or load lock is evacuated and ready for wafer transfers.

5.8.2 Robot control page

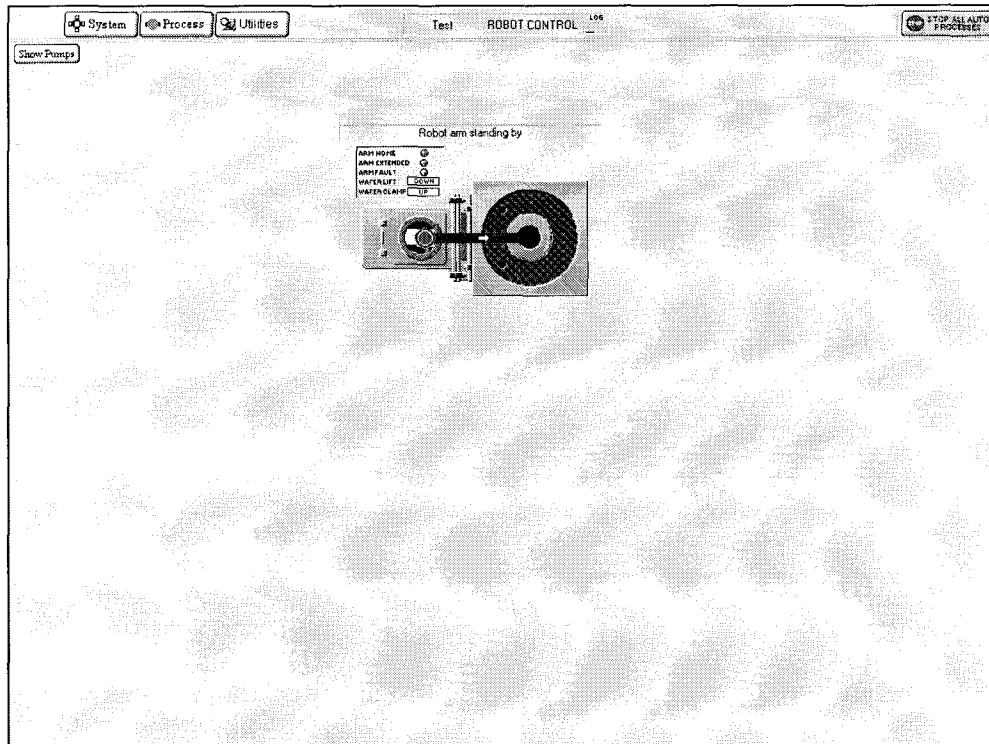

Fig 5.13: Robot control page

The Robot Control page is used to manually transfer a wafer between chambers (when operating in automatic mode, i.e. running a recipe, wafers are transferred automatically). The location of the wafer is indicated by a green wafer indicator. The arrowed path shows the currently available wafer destination.

The page provides the following features:

Show Pumps button	Displays the Pump Control page
Transfer arm and Wafer lift status panel	Displays indicators for ARM HOME, ARM EXTENDED and ARM FAULT (illuminated when active). Also displays WAFER LIFT and WAFER CLAMP status (up or down).
Transfer status message field	Displays context-related message about the wafer transfer progress.
Process chamber and Automatic load lock mimic	Displays the wafer location and possible wafer destination.

To transfer a wafer from the Automatic load lock to the process chamber to carry out a manual process, use the following steps:

- 1) Click on the Automatic load lock wafer mimic. The blue arrowed path is displayed showing the available destination.

- 2) Click on the process chamber wafer indicator. The wafer is transferred to the process chamber.

To transfer a wafer from a process chamber to the Automatic load lock on completion of a manual process, use the following steps:

- 1) Click on the process chamber's green wafer indicator. The blue arrowed path is displayed showing the available destination.
- 2) On the Automatic load lock mimic, click on the wafer indicator. The wafer is transferred to the Automatic load lock.

5.8.3 Recipe page

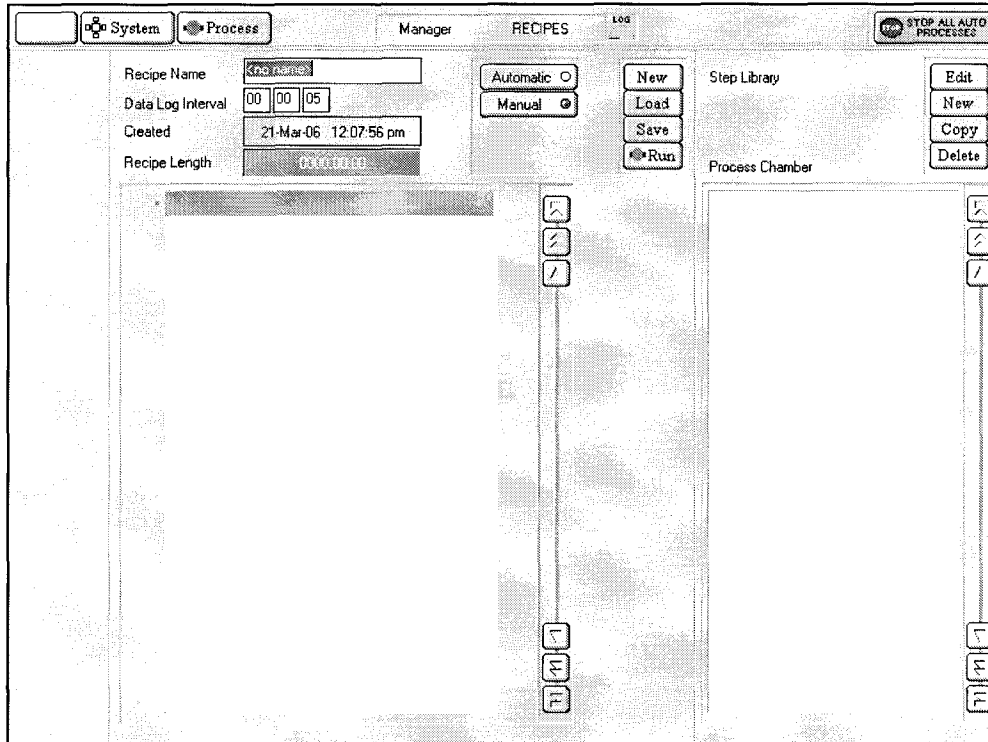

Fig 5.14: Recipe page

The recipe page is used to create, edit and run recipes. See sub-section 5.4.5 (Automatic process run, page 5-16) and sub-section 5.5 (Creating and editing recipes, page 5-21).

The facilities on this page are:

Automatic button Select to carry out an automatic process run using a recipe. The button's indicator is coloured yellow when selected.

The recipe will be performed on a substrate. The substrate will start at the normal wafer entry point and will be automatically transferred to each chamber, as the recipe requires. At the end of processing, the wafer will be returned to its starting point.

Manual button	Select to carry out a manual process run. The button's indicator is coloured yellow when selected. The recipe is associated with a chamber. If selected, further options 'wafer' and 'no wafer' are given. No automatic wafer transfers are performed; therefore a wafer must be loaded using the Robot Control page if required.
Recipe Name field	The name of the currently loaded recipe.
Data Log Interval field	Displays the data log interval, i.e. the time interval between the logging of system parameters.
Created field	The date and time of recipe creation.
Recipe length field	The length of time taken to run the recipe. This is the sum of all the process times, excluding wafer transfer time, process stabilisation and pumping times.
Recipe step list	A scrollable sequential list of steps contained in the recipe.
New button	Select to create a new recipe.
Load button	Select to load an existing recipe.
Save button	Select to save the current recipe.
Run button	Select to run the current recipe. Be aware that selecting this button will cause the robotic arm, slit valve, etc to operate!

Step Library Panel

Edit button	Select to edit the selected (highlighted) recipe step.
New button	Select to create a new recipe step.
Copy button	Select to copy the selected recipe (you are prompted for a new step name).
Delete button	Select to delete the selected (highlighted) recipe.
Step Library list	Displays the recipe steps available in a scrollable list.

5.8.4 Production mode page

The production mode page is automatically displayed when a user logs on in production mode. To use the production mode facility, refer to sub-section 5.4.7 (page 5-18).

Note that the **System** menu button can be used to select the pumping option. This provides the facility of evacuating and venting the automatic load lock.

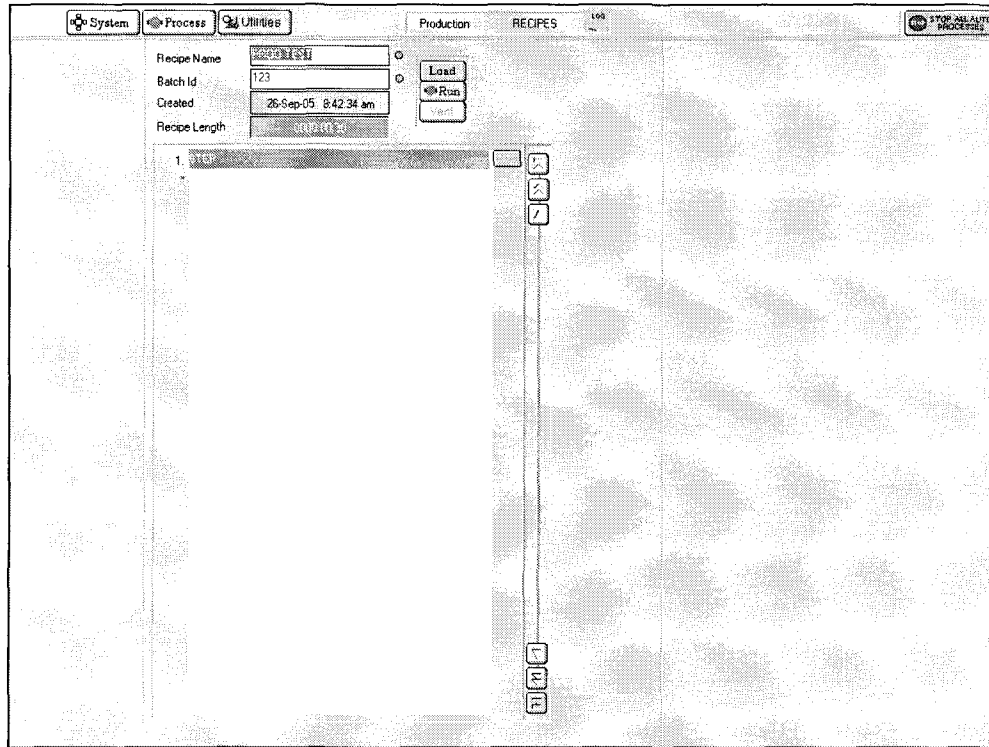

Fig 5.15: Production mode page

The facilities available on this page are:

- | | |
|----------------------------|---|
| Recipe Name field | The name of the currently loaded recipe. The indicator at the right of this field is coloured red until a recipe is loaded when it changes to green. |
| Batch Id field | Enter the batch identity of the currently loaded wafer. The indicator at the right of this field is coloured red until a batch identity is entered when it changes to green. |
| Created field | The date and time of recipe creation. |
| Recipe Length field | The length of time taken to run the recipe. |
| Load button | Select to load an existing recipe. |
| Run button | Select to run the current recipe. Be aware that selecting this button will cause system components, e.g. valves, heaters, etc., to operate! Note that this button only becomes active when a recipe has been loaded and a batch identity has been entered. |

Recipe step list A scrollable sequential list of steps contained in the recipe.

5.8.5 Chamber 1 process control page

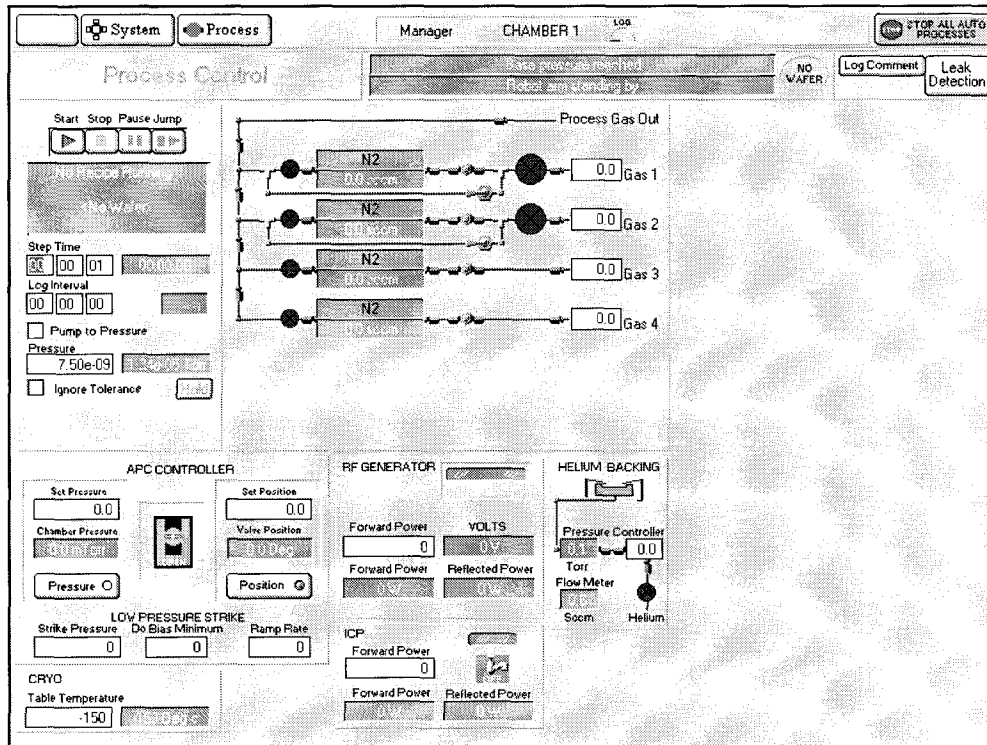

Fig 5.16: Chamber 1 process control page

This page is used to set the process parameters either for a manual run, or for a process step to be used in an automatic run recipe.

The facilities available on this page are:

- | | |
|---|---|
| Process chamber message field | Displays context related messages about the process chamber. |
| Transfer status/Log Comment message field | Displays context related messages about wafer transfer status. This field is also used to enter comments about the current process run which can be viewed on the log viewer page. |
| Wafer status field | Displays context related messages about the wafer currently in the Automatic load lock or process chamber. |
| Log Comment button | Allows comments about the current process to be entered in the Transfer status/Log Comment message field. While entering a comment, the button title changes to OK to allow the comment to be accepted. |
| Leak Detection button | Displays the leak detection page. See sub-section 5.8.6, page 5-45. |
| Start button | Select to start a manual process run using the parameters set on this page. |

Stop button	Select to stop the current process step.
Pause button	Select to pause the current process.
Jump button	Select to jump to the next process step.
Recipe message field	Displays information about the current recipe, step, loaded wafer identity, etc..
Step Time fields	Enter the required step time in hours:minutes:seconds. While a process is running, the adjacent field displays the time remaining to the end of the step.
Log Interval fields	Enter the interval required between data logging events.
Process status field	Indicates the process status; either Ready, Auto or Manual
Pump to Pressure checkbox	Select to create a pumping step. The system will pump down until the demanded pressure is reached. The step will remain active until this condition is met. Both RF Generators are automatically switched off during the step. (✓ Indicates selected). All setpoints are automatically set to zero, except for base pressure.
Pressure fields	Enter the required Process Chamber pressure for the step. The measured pressure is displayed in the adjacent field.
Ignore Tolerances checkbox	Select to disable tolerance checking during the current step. (✓ indicates selected).
Hold button	Used in multi-step recipes to keep the plasma on between steps.

NOTES:

The Hold button is only displayed on the Process Control page when a recipe is loaded. The Hold facility can be selected when creating/editing a process step using the Process Editor page.

When running the recipe, at the end of the process time for a process step without the Hold button selected, all process setpoints (chamber pressure, helium backing pressure, table temperature, RF power, ICP power, gas flow, etc) are set to zero (off) before starting the next process step. This means that the plasma would be extinguished between two plasma process steps if the Hold button were not selected.

When running the recipe, at the end of the process time for a process step with the Hold button selected, all process setpoints (chamber pressure, helium backing pressure, table temperature, RF power, ICP power, gas flow, etc) are set to the values of the next process step to run. This means that the plasma remains on between two plasma process steps if the Hold button is selected.

RF Generator
panel

Enter the required forward power. The forward power, reflected power, power ON/OFF status and DC bias are displayed.

Clicking the **Set Fwd Power** button toggles the demand between a forward power set point and a DC bias set point. If a DC bias demand is set, the RF power will be varied to try to achieve the required bias. Use this facility with care: if the plasma does not strike or if the DC bias cannot be read (by covering the table with insulator), then the RF power will increase to maximum.

ICP
GENERATOR
panel

Enter the required forward power. The forward power, reflected power, ON/OFF status are displayed.

CRYO panel

Enter the required table temperature. The current table temperature is displayed.

HELIUM
BACKING panel

Enter the required backing pressure. The current pressure (Torr) and flow rate (sccm) are displayed. The open/closed status of the control valve is displayed.

The table mimic, at the top of the panel, displays the up/down status of the wafer clamp and whether a wafer is loaded or not. The bitmaps below show all possible states of the mimic.

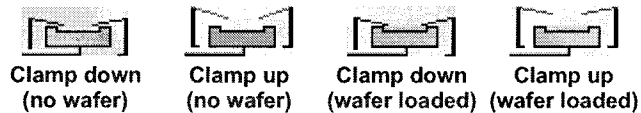
**APC**
CONTROLLER
panel

Select either the **Pressure** or the **Position** button. Enter the required Chamber Pressure or APC valve position. The current Process Chamber pressure, Valve Position and valve status are displayed.

**LOW PRESSURE
STRIKE** panel

The low pressure strike feature allows plasma processing at low pressures. When the gas pressure is too low, it is not possible to strike a plasma; however it is possible to sustain a plasma to very low pressures once it has been ignited. This software feature enables the user to raise the pressure temporarily, strike a plasma, and automatically reduce the pressure to the desired value for processing. The three data fields and their effects are:

**Strike
Pressure** field

Enter the value in mTorr at which the RF should turn on and strike the plasma. If a zero is entered, the feature is disabled and the RF will turn on once the pressure has stabilised at the requested process pressure.

**DC bias
Minimum**
field

Enter a positive number for the minimum DC bias value expected once the plasma has struck. Enter zero if DC bias cannot be read because the substrate (and any wafer clamp) completely cover the electrode, or if the electrode has an insulating coating. A non-zero value is used by the software to detect if the plasma has been properly established. If a zero is entered, then the software assumes the plasma has struck once the RF reflected power goes low.

Ramp Rate
field

Enter a number to set the rate at which the pressure is reduced from the strike value to the set point. The higher the number entered, the faster the transition to process conditions will be. Note that too high a value can cause the plasma to go out if the plasma impedance changes faster than the RF matching unit can track.

Process gas pod mimic Displays a mimic of the gas lines installed in the gas pod.

Enter the required gas flow in sccm for each gas line. Click on the Gas Name in an MFC mimic to edit the associated Gas Factors; the following dialogue is displayed.

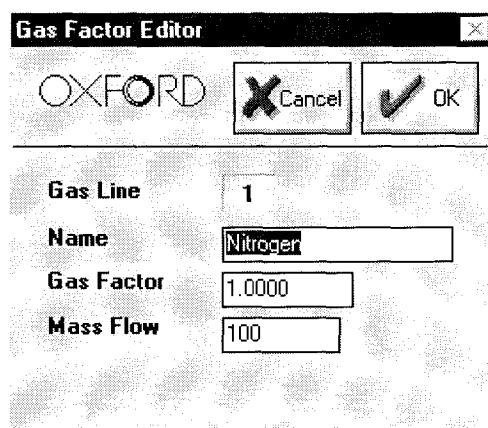

It is recommended to keep the **Gas Factor** as 1, and to put the full scale of the MFC for the gas used in the **Mass Flow** field.

For example, if Argon is used with a 100 sccm N₂ MFC. Put gas factor 1 and Mass Flow 141 sccm.

5.8.6 Leak detection page

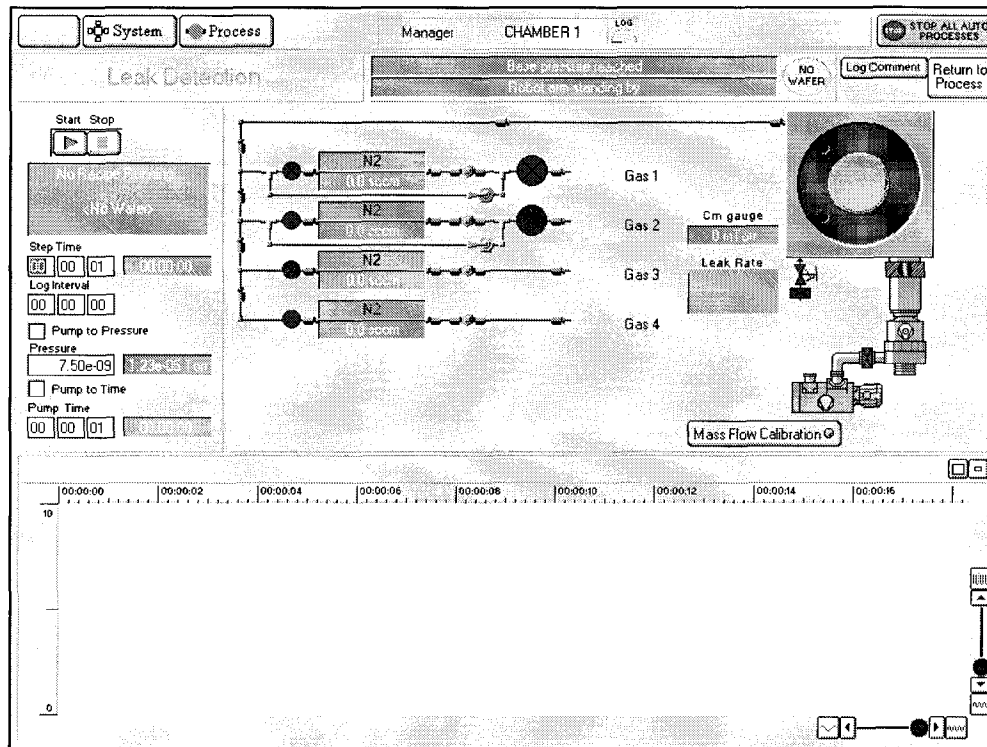

Fig 5.17: Leak detection page

The leak detection page, accessed from the Chamber 1 process page by selecting the **Leak Detection** button, allows you to perform automatic or manual leak detection runs. The Leak Detection page for a process chamber can be used to check the rate-of-pressure rise in a sealed chamber. The chamber is first pumped (either for a fixed time, or to a given pressure). The chamber then seals and the pressure rise rate is calculated. A graph of the chamber pressure against time is plotted. The test stops either when a test time elapses, or when the pressure gauge reaches full scale. The chamber is returned to pumping at the end of the test.

The rate-of-pressure rise will depend on:

- The leak rate from atmosphere. Leaks are not improved by more pumping.
- The outgassing rate from all surfaces.
- The 'virtual leak' rate from parts of the system furthest from the vacuum pump, especially gas feed pipes.

Outgassing and virtual leaks are reduced by more pumping. Outgassing is increased if the temperature of the whole system is raised.

The facilities available on this page are:

- | | |
|-------------------------------|--|
| Page function title field | Displays the current function of the page, i.e. Leak Detection |
| Process chamber message field | Displays context related messages about the process chamber. |

Transfer status/ Log Comment message field	Displays context related messages about wafer transfer status. This field is also used to enter comments about the current process run which can be viewed on the log viewer page.
Wafer status field	Displays context related messages about the currently selected wafer.
Log Comment button	Allows comments about the current process to be entered in the Transfer status/Log Comment message field. While entering a comment, the button title changes to OK to allow the comment to be accepted.
Return to Process button	Select to return to the Chamber 1 or Chamber 2 process page.
Start button	Select to commence a leak detection test.
Stop button	Select to halt a leak detection test and return to pumping.
Recipe message field	Displays information about the current recipe, step, loaded wafer identity etc.
Step Time fields	Enter the required step time (in hours:minutes:seconds) for the duration of the pressure-rise test. While a process is running, the adjacent field displays the time remaining to the end of the step.
Log Interval fields	Enter the sampling rate for the datalogging log file (in hours:minutes:seconds). <u>If set to zero, no data log will be made.</u>
Pump to Pressure checkbox	Select to cause the initial pumpdown to continue until a given pressure is reached. The step will remain active until this condition is met. (✓Indicates selected). All setpoints are automatically set to zero, except for base pressure. See the NOTE at the end of this sub-section.
Pressure fields	Enter the required Process Chamber target pressure. The measured pressure is displayed in the adjacent field.
Pump to time checkbox	Select to give the initial pumpdown a fixed duration. See the NOTE at the end of this sub-section.
Pump Time	Duration of initial pumpdown (in hours:minutes:seconds).
Gas pod and process chamber mimic	Displays a mimic of the gas pod, process chamber and vacuum system. The pressures read by the chamber Penning and CM gauges are also displayed.
Mass Flow Calibration button	Select to calibrate the MFCs. Calibration is carried out by clicking on each MFC mimic, then entering the Gas Name, Gas Factor and Mass Flow.
NOTE:	If both 'Pump to pressure' and 'Pump to time' are selected, then 'Pump to time' takes precedence.

5.8.7 Mass flow calibration page

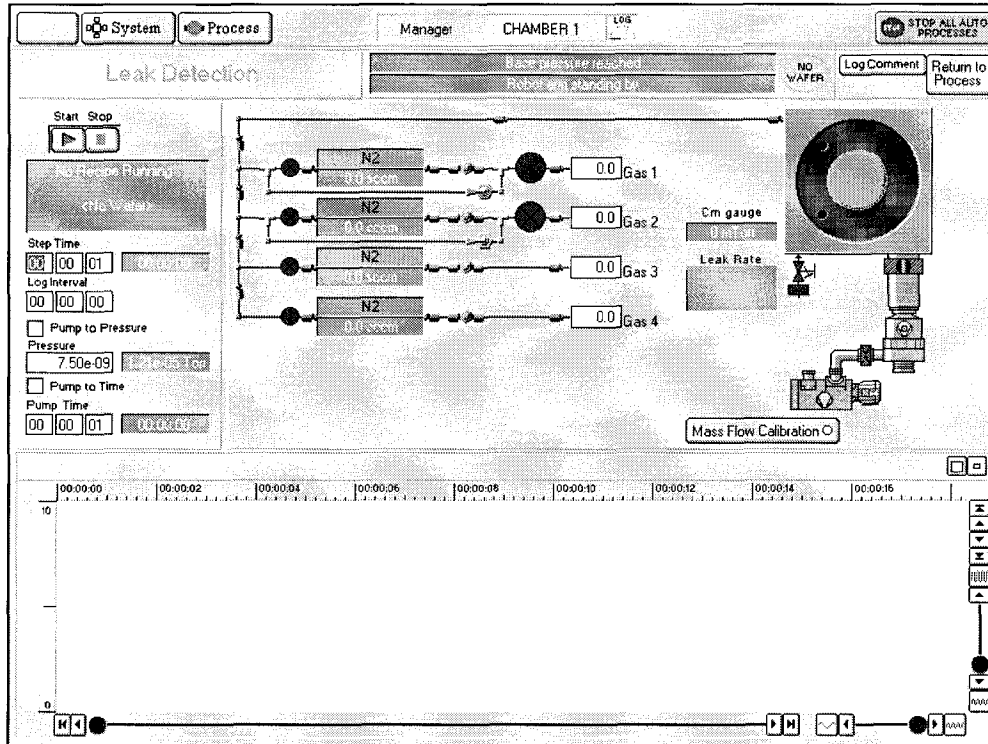

Fig 5.18: Mass flow calibration page

CAUTION

Some gas mixtures may produce particles in the chamber or gas lines.

Check only ONE gas at a time.

Allow at least 15 minutes of pumping before and after any chamber fill using Silane or SiCl₄.

This is similar to the Leak Detection page (see sub-section 5.8.6, page 5-45.) with the addition of setpoint boxes for the Mass Flow Controllers. Only the 'Pump to Time' feature should be selected, because the selected gases will turn on during the initial pumpdown period. (If 'Pump to pressure' is selected with a gas flowing, it is unlikely to reach the target pressure).

When the initial pumping and MFC stabilisation period ends, the chamber seals and fills slowly. The rate-of-pressure rise is calculated and displayed.

NOTE: Chamber pressure depends on quantity of gas added and on the chamber temperature. If a high-power plasma has been run recently, the chamber will be hotter and the rate-of-pressure rise will be greater for the same gas flow.

5.8.8 Service mode

The Service Mode page is displayed by selecting the **System** button, then the **Service** option.

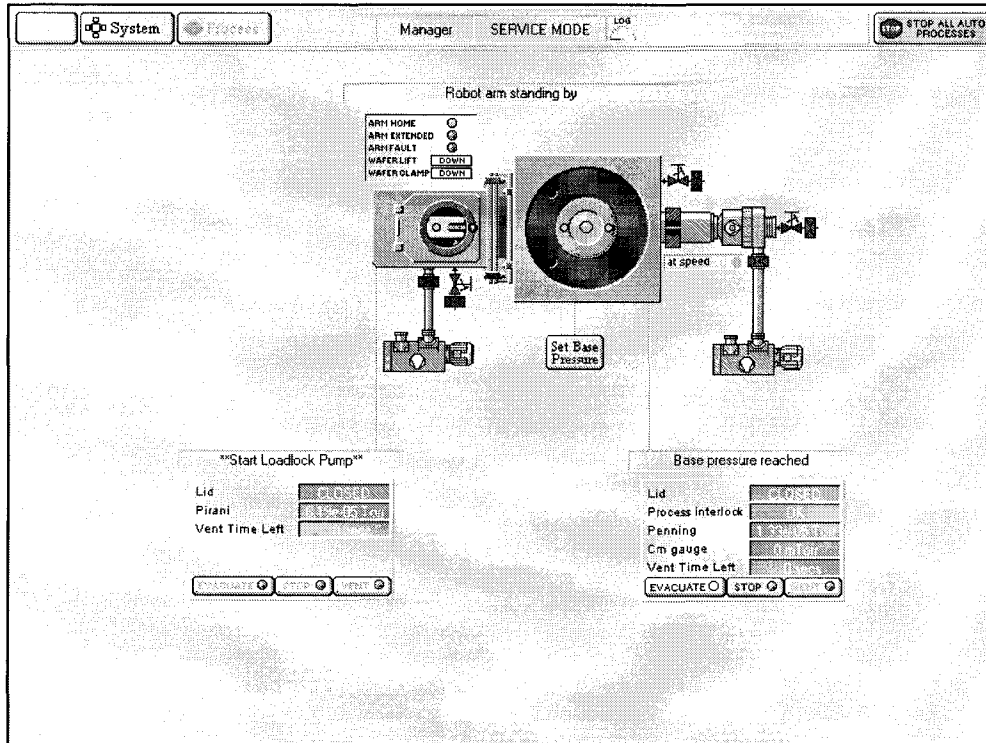

Fig 5.19: Service mode page

CAUTION

The software interlocks which prevent collisions between the wafer, robot arm, slit valve and the wafer clamp are overridden in the Service Mode. Therefore, before clicking on any button, consider very carefully the consequences of your proposed actions.

This page is used during maintenance to manually control system components. The page can also be used to manually transfer wafers between the Automatic load lock and process chamber.

Manual control of the following features is available by clicking on them (confirmation is requested before any action is carried out):

Note that moving the mouse pointer over a feature will cause a box to be displayed around the feature indicating that it can be manually controlled.

- Process chamber turbo pump.
- Process chamber wafer lift and wafer clamp.
- Process chamber vent valve.
- Process chamber APC valve.
- Process chamber turbo backing valve and purge valve.

- f) Process chamber rotary vane/dry pump.
- g) Automatic load lock transfer arm (click red dot to insert/withdraw arm).
- h) Automatic load lock isolating valve.
- i) Automatic load lock vent valve.
- j) Automatic load lock dry/rotary vane pump.
- k) Slit valve.

5.8.8.1 Transferring wafers in service mode

To transfer wafers between chambers in service mode, click on the wafer mimic (either in the Automatic load lock or process chamber). The following screen is displayed:

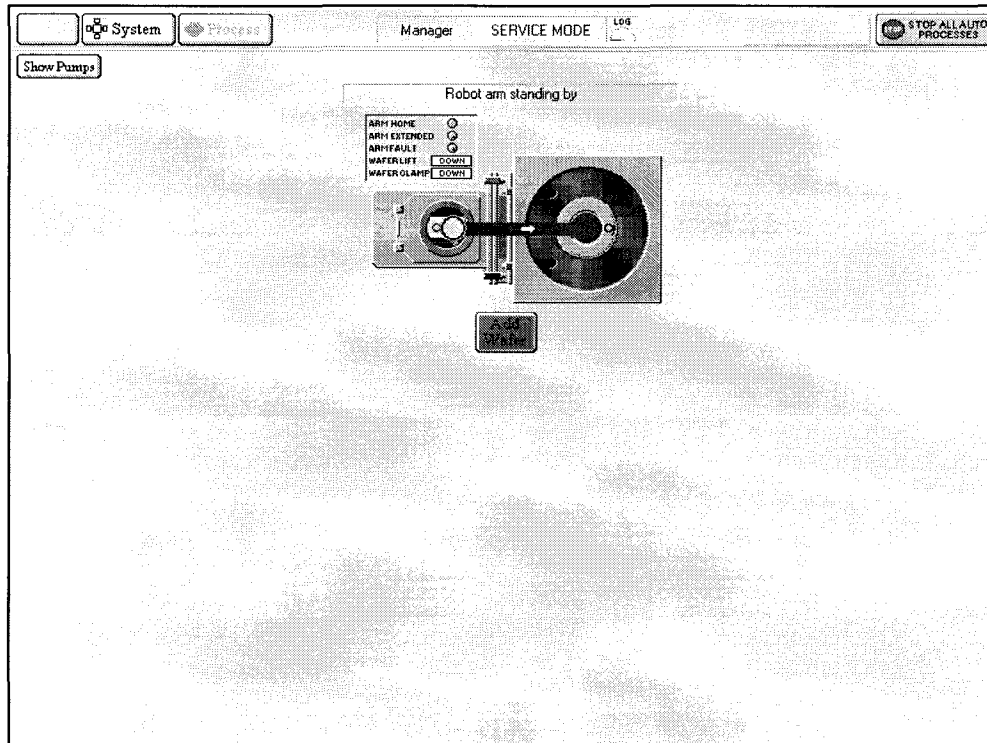

Fig 5.20: Wafer transfer in service mode

Click on the wafer destination. The wafer will be transferred.

The **ADD WAFER** button is used to inform the system that a wafer is present. This facility would be used if the machine were powered-up with a wafer in the Automatic load lock. The legend on this button changes to **KILL WAFER** when a wafer is present, enabling the selected wafer to be removed from system memory.

The page provides the following facilities:

Show Pumps button	Displays the Pump Control page
Message field	Displays status messages about the wafer transfer.
Add/Kill Wafer button	The ADD WAFER button is used to inform the system that a wafer is present. This facility would be used if the machine were powered-up with a wafer in the Automatic load lock. The legend on this button changes to KILL WAFER when a wafer is present, enabling the selected wafer to be removed from system memory.
Wafer transfer path	Displayed when the wafer mimic has been clicked. An arrow indicates the direction of the possible transfer. Clicking on the destination will cause the transfer to be carried out.

5.8.8.2 Exiting from service mode

To exit from service mode, select the system menu and then the **Exit Service** option. The following dialogue box is displayed:

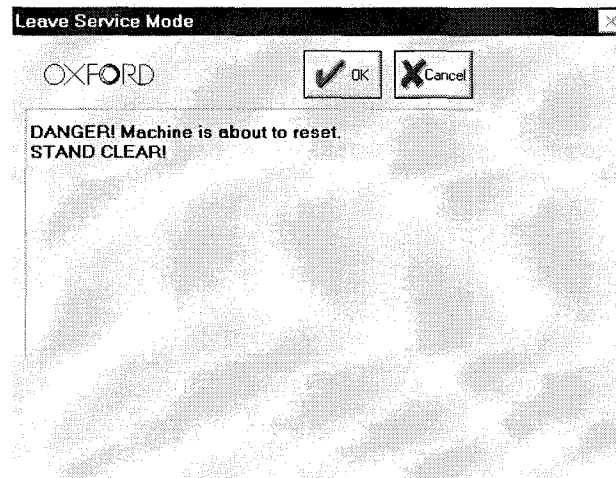

Ensure that there are no personnel close to the system, and then select the **OK** button.

After exiting from service mode, the system configuration will depend on which service mode facilities were used as follows:

- If no service mode facilities were used, e.g. no valves were open or closed; the system configuration will be the same as it was before entering service mode.
- If the service facilities were used, the system configuration will depend on which of the facilities were used as follows.

To prevent damage to the system, any chamber which had any of its features altered in service mode, e.g. valves opened/closed, pumps turned on/off etc., will have its pumping stopped. All other chambers will continue to be pumped.

To return the chamber which had its pumping stopped to the pumping or vent state, click on the associated **Stop** button, and then on the **Evacuate** button or the **Vent** button as required. The chamber will then pump down or vent.

5.8.9 System log page

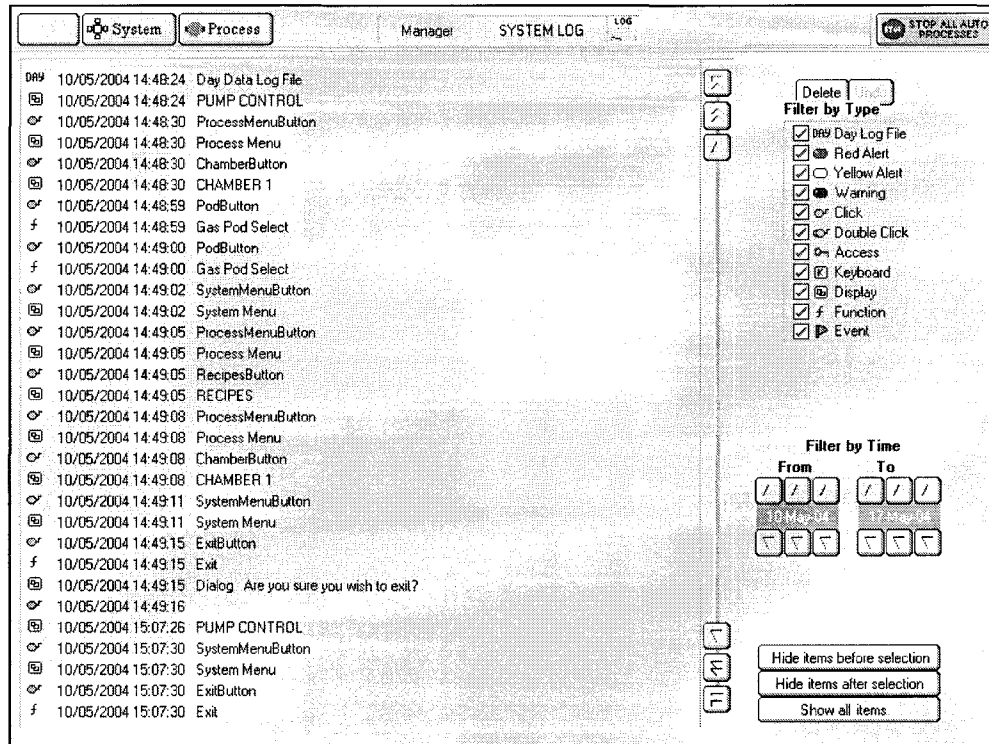

Fig 5.21: System log page

The system log page allows logged system events to be viewed. A filter facility allows the viewed events to be displayed by event type and time of occurrence.

The page provides the following features:

- Event list:** A scrollable list of events in date/time order. Each event is categorised by an icon, and an event description is given. Use the scrollbar and associated buttons to move the list up or down by a single event, a page of events or to the end of the list.
- Delete button** Removes the selected event(s) from the Event list.
- Undo button** Only active after a Delete action. Restores the last deleted event.
- Filter by Event Type panel:** A list of event types with associated checkboxes. Use this panel to select the events to display in the Event list. A checkbox showing an 'x' indicates that the associated event type will not be displayed. A checkbox showing a '✓' indicates that the associated event type will be displayed.
- Filter by time controls:** Use these controls to select events occurring in a time range to be displayed.
- Hide events before selection button** Displays all events after and including the highlighted event.

Hide events after selection button	Displays all events before and including the highlighted event.
Show all events button:	Displays all previously hidden events.

5.9 Log files

While PC 2000 is running, two log files are maintained, one for the system log and the other for the data log. These files are stored on your hard disk in the folder **C:\Optysyslg**. Details of the log files are as follows.

System log file – The filename for this file is of the form **s0Caabb** where **aa** represents the month, e.g. 06 (for June) and **bb** represents the day of the month, e.g. 11 (for the eleventh day).

Data log file – The filename for this file is of the form **p1caabb** where **aa** represents the month, e.g. 06 (for June) and **bb** represents the day of the month, e.g. 11 (for the eleventh day).

When PC 2000 is shut down correctly (select the System menu, then the **Exit** option), both log files are automatically saved and closed. If PC 2000 is then started again, the files are automatically opened and their data is available via the System Log page and the Select Log Data page.

If PC 2000 is not shut down correctly, e.g. the PC is switched off or the PC 'hangs' etc., one or both of the log files can become corrupted. If this happens, the next time PC 2000 is started the corrupt log file(s) will be detected and reported on-screen by an error dialogue. To correct this problem, use the following procedure:

- 1) Close PC 2000.
- 2) Use Windows Explorer to navigate to **C:\Optysyslg**.
- 3) Delete the reported log file.
- 4) Re-start PC 2000.

WARNING**BEFORE PROCEEDING WITH ANY MAINTENANCE WORK, READ SECTION 1 - HEALTH AND SAFETY.****6. Maintenance**

6. Maintenance	6-1
6.1 Customer support facilities	6-3
6.2 General	6-4
6.3 Safety maintenance	6-5
6.3.1 Inspection and renewal	6-5
6.3.1.1 Quartz components	6-5
6.3.1.2 Alumina components	6-5
6.4 94-100-BW-2F Base wired 2-frame kit	6-6
6.4.1 Weekly	6-6
6.4.2 Monthly	6-6
6.4.3 Three-Monthly	6-7
6.4.4 Annually	6-7
6.4.5 Changing the gas bottles	6-7
6.4.6 Etch cleaning	6-7
6.5 94-100-3-41C ICP 180 chamber kit with gate valve	6-9
6.5.1 Monthly	6-9
6.5.2 O-rings	6-9
6.6 Top electrode	6-10
6.6.1 Monthly	6-10
6.6.2 Six-monthly (tools with a removable showerhead)	6-10
6.6.3 Annually (tools having access to the gas inlet isolation assembly from the top side only)	6-10
6.7 94-100-5-12A Cryo He lower electrode	6-11
6.7.1 Monthly	6-11
6.8 94-100-6-500/200V RIE 500W RF generator / OIPT AMU kit	6-12
6.8.1 Three-monthly	6-12
6.9 Vacuum system	6-13
6.9.1 Active Pirani gauge	6-13
6.9.2 Capacitance manometer	6-13
6.9.2.1 Six-monthly (or as necessary)	6-13
6.9.3 Penning gauge	6-13
6.9.3.1 Dismantling the body tube	6-14
6.9.3.2 Cleaning	6-15
6.9.4 Turbomolecular pumps	6-15
6.9.4.1 Daily	6-15
6.9.4.2 Re-greasing of turbo pumps fitted to process chambers	6-15
6.9.4.3 2000 to 8000 hours (3 to 12 months): pump relubrication	6-15
6.9.4.4 Alcatel turbo pumps fitted with bake-out collars	6-16
6.9.5 Rotary vane pumps	6-16
6.10 Gas handling system	6-17
6.10.1 Wall-mounted gas pod	6-17
6.10.1.1 Annually	6-17
6.10.2 Mass flow controllers	6-17
6.10.2.1 Annually (or as necessary)	6-17
6.10.3 Filters	6-17
6.10.3.1 Annually (or as necessary)	6-17
6.11 Pump lubricants	6-18

WARNING**BEFORE PROCEEDING WITH ANY MAINTENANCE WORK, READ SECTION 1 - HEALTH AND SAFETY.**

6.11.1	General.....	6-18
6.11.2	Perfluorised polyethers	6-18
6.11.3	Hydrocarbon lubricants.....	6-19
6.12	94-100-5-12A Cryo / heated -150 / 400C He lower electrode wafer clamping plate changeover procedure	6-19
6.13	Adjusting the lower electrode wafer clamp clamping force	6-21
6.14	Automatic load lock end effector adjustments for different wafer sizes.....	6-22
Fig 6.1:	94-100-5-12A Cryo / heated -150 / 400C He lower electrode	6-20
Fig 6.2:	Clamping force adjustment	6-21
Fig 6.3:	End effector wafer size adjustments.....	6-22

WARNING**BEFORE PROCEEDING WITH ANY MAINTENANCE WORK, READ SECTION 1 - HEALTH AND SAFETY.**

6.1 Customer support facilities

Oxford Instruments Plasma Technology has global Customer Support Facilities to provide a co-ordinated response to customer's queries. All queries are recorded on our Support Database and dealt with as quickly as possible. If we are not able to answer the query immediately, we will contact you as soon as possible.

Before contacting a Customer Support Facility, please ensure that you have referred to the appropriate section of your system manual, OEM manuals and electrical drawings.

Please direct all queries through your nearest support facility (see below) and have the following details available.

System Type, e.g. **PlasmalabSystem100** etc.

Works Order No. – This can be found on the front cover of your system manual.

Contact Information – Your name, Company and how we can contact you.

Details of your query – nature of the problem, part numbers of spares required, etc.

You can contact us via any of the following:

China**Beijing**

Tel: +86 106518 8160

Email: pt.support@oichina.cn

Shanghai

Tel: +8621 6360 8530

Email: pt.support@oichina.cn

Germany

Tel: +49 6122 937 161

Email: info@oxford.de

Japan

Tel: +81 3 5245 3591

Email: oikkpt@oxinst.co.jp

Singapore

Tel: +65 6337 6848

Email: pt.support@oxford-instruments.com.sg

Taiwan

Tel: +886 3 5788696

Email: pt.support@oxford-instruments.com.tw

UK

Customer Support Hotline: +44(0) 1934 837070

(0800 – 2000 UK local time)

Fax: +44(0) 1934 837071

Email: pt.support@oxinst.co.uk

USA

Concord, MA

Tel: +1 978 9933 ext. 444

Toll Free: +1 800 447 4717 ext. 444

Fax: +1 978 369 8287

Email: support.pt@ma.oxinst.com

WARNING

BEFORE PROCEEDING WITH ANY MAINTENANCE WORK, READ SECTION 1 - HEALTH AND SAFETY.

6.2 General**WARNINGS**

- A) BEFORE STARTING ANY MAINTENANCE WORK, SWITCH OFF AND LOCK OFF THE WALL-MOUNTED SAFETY ISOLATION BOX.**
- B) ENSURE THAT ONLY FULLY AND APPROPRIATELY QUALIFIED PERSONNEL ARE ALLOWED TO WORK ON THE SYSTEM.**
- C) READ SECTION 1 - HEALTH AND SAFETY AT THE BEGINNING OF THIS MANUAL.**

WARNING

ISOPROPYL ALCOHOL IS HIGHLY INFLAMMABLE (FLAMMABLE). DO NOT USE IT NEAR A NAKED FLAME OR ENERGISED ELECTRICAL EQUIPMENT.

CAUTION

When changing or topping up oil in a pump, always use oil of the same brand and type.

Always replace filters with those of a similar type and brand.

WARNING**BEFORE PROCEEDING WITH ANY MAINTENANCE WORK, READ SECTION 1 - HEALTH AND SAFETY.**

6.3 Safety maintenance

Induction coupled plasma sources contain quartz or alumina tubes or windows under vacuum, which may be subject to attack by the plasma process. If these components fail whilst under vacuum, an implosion can occur. This should not present a safety hazard, provided the equipment is used with all covers and screens in place, but may cause damage to system components.

Failure by implosion becomes more likely as the components age, therefore they should be regarded as consumable items. A programme of regular inspection and renewal of these components is necessary to minimise the risk of implosion.

6.3.1 Inspection and renewal

WARNING**DISCARDED COMPONENTS MAY BE CONTAMINATED WITH RESIDUES FROM THE PLASMA PROCESS AND MAY BE ACIDIC OR TOXIC. DISPOSE WITH REGARD TO LOCAL PRACTICES.**

IMPORTANT: The following inspection intervals should be reduced if the source is operated for prolonged periods at high powers, especially for quartz components operating in fluorine-containing plasmas.

6.3.1.1 Quartz components

The internal surfaces of these components should be inspected at intervals of three months or less. Components showing significant signs of wear should be discarded and replaced by a new component. For details of changing the ICP 180 dielectric tube, refer to the ICP 180 Equipment Manual Section 6 (Maintenance).

6.3.1.2 Alumina components

The internal surfaces of these components should be inspected at intervals of six months or less. Components showing significant signs of wear should be discarded and replaced by a new component. For details of changing the ICP 180 dielectric tube, refer to the ICP 180 Equipment Manual Section 6 (Maintenance).

WARNING**BEFORE PROCEEDING WITH ANY MAINTENANCE WORK, READ SECTION 1 - HEALTH AND SAFETY.****6.4 94-100-BW-2F Base wired 2-frame kit****6.4.1 Weekly**

Examine the exterior of the machine for damage or signs of overheating and for failed indicator lamps.

Closed loop (recirculating) cooling systems:

Top up with Hexid A40 coolant (Oxford Plasma Technology Part No. G/WTR/SUN/007 for 15 litres). This product is propylene glycol based and is pre-diluted ready for use. Refer to Appendix S (Services Specifications for Plasmalab and Ionfab systems) sub-section 2.1 for the warranty impact of not using this product.

6.4.2 Monthly

- 1) Monitor the vacuum integrity of the system by pumping thoroughly, isolating the process chamber and noting the rate of pressure rise. An abnormally high value (i.e. > 2mTorr/minute) may indicate a leak or heavy contamination of the process chamber. (The chamber can be isolated by clicking the **Stop** button on the corresponding Pump Control page.)
- 2) Monitor the backing pump(s)' condition by timing how long it takes to pump from atmosphere to 0.1 Torr (without a turbomolecular pump turned on). An increase in time may indicate deteriorating pump performance.
- 3) Check the zero setting of the Capacitance Manometer (CM gauge). Note that the CM gauge output does not stabilise until it has been switched on and under vacuum for 15 minutes. A turbo pumped system will have a base pressure well below 0.1 mTorr, so the zero point can be adjusted readily in this case (see manufacturer's data). A Roots / rotary combination should give a base pressure below 1 mTorr, and can be used to set the zero point of a 10 Torr gauge. A rotary pump should give a base pressure below 10 mTorr, so a true zero pressure cannot be set in this case. Either the gauge should be set to the same arbitrary reference level (e.g. 10 mTorr), or it should be set to zero on another vacuum system with a known base pressure, and carefully re-installed in the System 100.
- 4) Monitor the performance of each mass flow controller, by noting the system pressure with 10%, 50% and 100% flow setpoints and the throttle fully open. A change may indicate a deterioration in MFC performance, or a change in pumping speed.

WARNING**BEFORE PROCEEDING WITH ANY MAINTENANCE WORK, READ SECTION 1 - HEALTH AND SAFETY.****6.4.3 Three-Monthly**

- 1) Heater/chiller unit (on closed loop cooling systems).

If the condenser on the refrigeration circuit is air-cooled, it should be kept clean enough to allow the free flow of air through it. Dirt can be removed by brushing or vacuum cleaning.

Radio frequency radiation leakage:

Carry out the Radio Frequency radiation leakage tests as detailed in Appendix A 'Measurement of RF and microwave emissions'.

6.4.4 Annually

- 1) Replace or clean the filters used in the compressed air supply system.
- 2) Replace the filters in the cooling water system.
- 3) Where closed loop (recirculating) water cooling systems are used, drain the system and replace the coolant with Hexid A40 coolant (Oxford Plasma Technology Part No. G/WTR/SUN/007 for 15 litres). This product is propylene glycol based and is pre-diluted ready for use. Refer to Appendix S (Services Specifications for Plasmalab and Ionfab systems) sub-section 2.1 for the warranty impact of not using this product.

6.4.5 Changing the gas bottles

The operator should be aware that certain process parameters may change as the process gas bottles pressure drops. For example, inert gas bottles which are normally filled to about 3000 psi, should be changed when the pressure drops below 400 psi. The inlet pressure should be 25 - 35 psia. Before disconnecting the empty bottle it is advisable to thoroughly evacuate the gas line (by closing the gas bottle tap and pumping the line via the MFC). The line should then be filled with dry N₂ if available.

Once the new bottle has been connected, monitor the vacuum integrity of the gas line before opening the bottle by setting a high flow on the MFC, pumping the line thoroughly (via the MFC), isolating the process chamber and noting the rate of pressure rise. An abnormally high value (>2mTorr/minute) may indicate a leak in the gas line or the regulator to bottle connection.

During normal operation the bottle pressure and line pressure on the cylinder regulator should be regularly checked for loss of pressure during periods when the gas bottle tap is turned off (during shut-down periods, overnight or over a weekend). This will indicate a leak from the gas line or the regulator.

6.4.6 Etch cleaning

Where the system is used for Plasma Enhanced Chemical Vapour Deposition (PECVD), the manual processing runs should be interspersed with etching processes as an efficient method of cleaning the electrodes and chamber walls.

The etching processes may be optimised to suit particular processing requirements; however, the following recommendations may be used as a starting point.

WARNING**BEFORE PROCEEDING WITH ANY MAINTENANCE WORK, READ SECTION 1 - HEALTH AND SAFETY.**

The etch cleaning should be performed each time the aggregate of the deposition layers reaches ~10 microns.

The recommended clean process is:

CF_4/O_2 8% or 20%, 700mTorr, 200W, ≥ 30 minutes

This process is optimised for rapid electrode cleaning. If it is found that the cleaning rate of the chamber walls is too slow with the above process, then a low pressure process can also be used:

CF_4/O_2 8% or 20%, 350mTorr, 200W, ≥ 30 minutes

The two processes can be alternated until the chamber and electrodes are etched clean.

A chamber conditioning step (using the normal deposition conditions in the empty chamber to deposit 0.2-0.5 μm) is recommended before processing wafers.

WARNING

BEFORE PROCEEDING WITH ANY MAINTENANCE WORK, READ SECTION 1 - HEALTH AND SAFETY.

6.5 94-100-3-41C ICP 180 chamber kit with gate valve

WARNING

BEFORE ATTEMPTING ANY MAINTENANCE WORK ON THE PROCESS CHAMBER, IT MUST BE SUBJECTED TO AT LEAST TWO VENT CYCLES SUBSEQUENT TO A PROCESSING RUN.

6.5.1 Monthly

- 1) Visually examine the interior of the chamber for contamination. Any necessary cleaning should be carried out using a lint-free cloth moistened with Isopropyl Alcohol (IPA). Tougher deposits can be removed using an abrasive pad first.

WARNING

ISOPROPYL ALCOHOL IS HIGHLY INFLAMMABLE (FLAMMABLE). DO NOT USE IT NEAR A NAKED FLAME OR ENERGISED ELECTRICAL EQUIPMENT.

Examine the exterior of the chamber and its fittings for damage.

Examine the lid and seals for any damage or deterioration.

Examine the heating/cooling water flow system for signs of leakage.

Purge the process chamber for thirty minutes with dry nitrogen if IPA has been used for cleaning.

Visually examine the top electrode for contamination. Any necessary cleaning should be carried out using a lint-free cloth moistened with Isopropyl Alcohol (IPA).

Examine the top electrode and its integral gas and water fittings for damage.

Examine the seals for signs of deterioration.

6.5.2 O-rings

The O-rings should be checked monthly but replaced as and when necessary.

Replacement O-rings should be constructed of Viton and pre-baked to 150°C to minimise the risk of water vapour from the O-rings. The chamber lid O-ring should not need to be removed unless it leaks. Clean the O-ring *in situ* using a lint-free cloth wetted with Isopropyl Alcohol.

To change the lid O-ring (use gloves):

- 1) Remove the O-ring, being careful not to damage the retaining groove.
- 2) Use a lint-free cloth and IPA to clean the O-ring sealing face on the chamber.
- 3) The new O-ring, cleaned with IPA, should be inserted with no twists. Stretch the O-ring evenly as it is inserted to avoid local regions of stretching.

WARNING

BEFORE PROCEEDING WITH ANY MAINTENANCE WORK, READ SECTION 1 - HEALTH AND SAFETY.

6.6 Top electrode

WARNING

BEFORE ATTEMPTING ANY MAINTENANCE WORK ON THE PROCESS CHAMBER, IT MUST BE SUBJECTED TO AT LEAST TWO VENT CYCLES SUBSEQUENT TO A PROCESSING RUN.

6.6.1 Monthly

- 1) Visually examine the top electrode for contamination. Any necessary cleaning should be carried out using a lint-free cloth moistened with Isopropyl Alcohol (IPA).

WARNING

ISOPROPYL ALCOHOL IS HIGHLY INFLAMMABLE (FLAMMABLE). DO NOT USE IT NEAR A NAKED FLAME OR ENERGISED ELECTRICAL EQUIPMENT.

- 2) Examine the top electrode and its integral gas and water fittings for damage. Carefully inspect gas inlet showerhead plates for signs of plasma concentrating in a hole and enlarging the hole.
- 3) Examine the seal for signs of incipient deterioration.

6.6.2 Six-monthly (tools with a removable showerhead)

Check the condition of the gas inlet isolation assembly for any signs of brown discoloration of the white PTFE. (It goes brown sometimes before failing with a major enlargement of the through-holes.)

6.6.3 Annually (tools having access to the gas inlet isolation assembly from the top side only)

Check the condition of the gas inlet isolation assembly for any signs of brown discoloration of the white PTFE. (It goes brown sometimes before failing with a major enlargement of the through-holes.)

WARNING

BEFORE PROCEEDING WITH ANY MAINTENANCE WORK, READ SECTION 1 - HEALTH AND SAFETY.

6.7 94-100-5-12A Cryo He lower electrode**WARNING**

BEFORE ATTEMPTING ANY MAINTENANCE WORK ON THE PROCESS CHAMBER, IT MUST BE SUBJECTED TO AT LEAST TWO VENT CYCLES SUBSEQUENT TO A PROCESSING RUN.

6.7.1 Monthly

- 1) Visually examine the substrate table for contamination. Any necessary cleaning should be carried out using a lint-free cloth soaked in Isopropyl Alcohol (IPA).

WARNING

ISOPROPYL ALCOHOL IS HIGHLY INFLAMMABLE (FLAMMABLE). DO NOT USE IT NEAR A NAKED FLAME OR ENERGISED ELECTRICAL EQUIPMENT.

Examine the table and its integral heating and/or cooling systems for signs of damage.

WARNING**BEFORE PROCEEDING WITH ANY MAINTENANCE WORK, READ SECTION 1 - HEALTH AND SAFETY.****6.8 94-100-6-500/200V RIE 500W RF generator / OIPT AMU kit****6.8.1 Three-monthly**

Ensure that the RF/microwave radiation leakage tests, detailed in Appendix A are carried out.

For details of maintenance required, refer to the manufacturer's literature in Volume 3 of this manual.

WARNING**BEFORE PROCEEDING WITH ANY MAINTENANCE WORK, READ SECTION 1 - HEALTH AND SAFETY.****6.9 Vacuum system****6.9.1 Active Pirani gauge**

Refer to the manufacturer's literature in Volume 3 for details of the following maintenance:

- a) Atmosphere and vacuum adjustment.
- b) Filter cleaning.

6.9.2 Capacitance manometer**6.9.2.1 Six-monthly (or as necessary)**

- 1) Remove the capacitance manometer from the process chamber.

WARNING**ISOPROPYL ALCOHOL IS HIGHLY INFLAMMABLE (FLAMMABLE). DO NOT USE IT NEAR A NAKED FLAME OR ENERGISED ELECTRICAL EQUIPMENT.**

Carefully pour a measure of Isopropyl Alcohol (IPA) at room temperature into the pressure-measurement cavity. Do not allow IPA to come into contact with electronic components.

Agitate the solvent carefully and then pour it out.

CAUTION**Because the diaphragm in the gauge is thin tensioned metal, it can be destroyed by sudden changes in temperature or by clumsy handling.**

Re-install the gauge, allowing sufficient time for outgassing of the cavity and diaphragm prior to operation.

NOTE: Refer to the manufacturer's manual for calibration adjustments.

6.9.3 Penning gauge

The following applies to an Edwards Active Inverted Magnetron gauge. If a different Penning gauge is fitted, refer to the manufacturer's literature.

WARNING**BEFORE PROCEEDING WITH ANY MAINTENANCE WORK, READ SECTION 1 - HEALTH AND SAFETY.****WARNING****IF THE ELECTRONICS ARE DISCONNECTED FROM THE BODY TUBE AND THE BODY TUBE IS LEFT CONNECTED TO A VACUUM SYSTEM, THEN IF A PLASMA DISCHARGE IS MAINTAINED IN THE VICINITY OF THE BODY TUBE, THE ANODE AND GUARD RING OF THE BODY TUBE ASSEMBLY MAY BECOME CHARGED UP.****SWITCH OFF THE POWER SUPPLY BEFORE REMOVING THE GAUGE FROM THE VACUUM SYSTEM. HIGH VOLTAGES EXIST INTERNALLY IN THE GAUGE. THE CONNECTING CABLE SHOULD BE REMOVED BEFORE ATTEMPTING TO DISMANTLE THE GAUGE.****6.9.3.1 Dismantling the body tube**

The body tube assembly can be removed from the gauge by gripping the magnet housing and twisting the body tube flange clockwise to unlock the bayonet fitting. The tube can then be completely withdrawn from the gauge electronics / magnet housing.

The electrode can be removed from the body tube for cleaning / replacement as follows:

Using the flat spanner provided with the spares kit, locate the two lugs in the end of the collar and rotate anti-clockwise to completely unscrew. Once the collar is removed, the anode assembly and O-ring can be withdrawn.

The two cathode cups are removed from the flange end of the body tube by releasing the circlip using a pair of circlip pliers. Note the correct orientation of the cups. The cup with the reduced central hole size should be closest to the O-ring end of the body tube.

Re-assembly is the reverse procedure, taking care not to bend the anode, and ensuring that it is centralised in the body tube when tightening the threaded collar.

WARNING**BEFORE PROCEEDING WITH ANY MAINTENANCE WORK, READ SECTION 1 - HEALTH AND SAFETY.****6.9.3.2 Cleaning****WARNING****ISOPROPYL ALCOHOL IS HIGHLY INFLAMMABLE (FLAMMABLE). DO NOT USE IT NEAR A NAKED FLAME OR ENERGISED ELECTRICAL EQUIPMENT.**

The cathode cups, body tube and anode assembly can be cleaned by firstly degreasing in a proprietary degreasing agent, and then thoroughly soaking in a laboratory detergent. After soaking, the parts should be thoroughly rinsed in clean water and then in Isopropyl Alcohol, to remove all traces of water. The parts should be dried thoroughly.

6.9.4 Turbomolecular pumps

Refer to the manufacturer's literature in Volume 3 for details of maintenance required. Also, refer to Appendix B 'Operation and Maintenance of Turbomolecular Pumps'.

6.9.4.1 Daily

Ensure that the turbo pump temperature is sufficiently high, i.e. $>50^{\circ}\text{C}$. The turbo pump temperature can be monitored on the turbo pump controller's display. Refer to the pump manufacturer's manual for details. If the turbo pump temperature is too low, adjust the manually-operated flow valve to reduce the flow rate of the turbo pump cooling water.

6.9.4.2 Re-greasing of turbo pumps fitted to process chambers

The following instruction applies to conventionally greased bearing turbo pumps, e.g. the Alcatel ATP series. It does not apply to Maglev turbo pumps.

To prevent damage to turbo pumps fitted to process chambers, OIPT strongly recommends that bearing re-greasing is carried out periodically after every 2500 hours of pump running time.

Details of re-greasing are given in sub-section 6.9.4.3.

6.9.4.3 2000 to 8000 hours (3 to 12 months): pump relubrication**CAUTION****Failure to perform regular pump maintenance will result in pump warranty being suspended.**

Refer to the manufacturer's manual in Volume 3 of this manual.

Alcatel ATP series turbo pumps are conventional greased bearing pumps. Periodically, these bearings need to be re-greased.

The re-greasing interval depends on a number of factors; Refer to the graph in the Maintenance section of the manufacturer's manual to establish the re-greasing interval for the pump in your system. **Remember that turbo pumps fitted to process chambers must be re-greased at 2500 hour intervals.** The re-greasing interval for turbo pumps

WARNING

BEFORE PROCEEDING WITH ANY MAINTENANCE WORK, READ SECTION 1 - HEALTH AND SAFETY.

fitted to load locks and transfer chambers is not so critical, therefore the manufacturer's recommendations can be used.

The ATP turbo pumps are supplied with series ACT intelligent controllers which are menu-driven. The 'SET-UP' menu allows the re-greasing interval to be set so that a visual warning with an optional audible alarm is displayed at the relevant time. Note that this visual warning does not require any action immediately; it only indicates that the bearing should be re-greased at the next available opportunity. If required, the visual warning and audible alarm can be disabled via the 'SET-UP' menu.

When the pumps are supplied, the ACT controller is pre-set with a 5,000 hour re-grease interval. If the pumps are running continuously, the visual re-grease warning will be automatically triggered after approximately seven months.

The customer is advised to use the 'SET-UP' menu to set the re-greasing interval for the pump fitted to his system. Refer to the pump manufacturer's manual. Note that this change takes approximately five minutes.

When the re-greasing time is reached, lubrication is carried out using a pre-loaded syringe to apply a metered quantity of a specific grease to one point on the bearing. Refer to the pump manufacturer's manual. The Alcatel part numbers of the syringes are:

Pump Type	Pre-loaded Syringe Part Number
ATP80	056993
150C/400HPC/900HPC	101924

Note that the grease syringe has a limited shelf life so shouldn't be ordered from the Alcatel service centre until it is needed. Alcatel exercises strict stock control on this item to ensure that the grease is always in good condition.

Once the grease has been applied to the bearing, it needs to be evenly distributed around the bearing. This is done automatically by using the ACT controller's 'RUNNING IN' menu.

Note that the grease distribution takes approximately 2.5 hours.

6.9.4.4 Alcatel turbo pumps fitted with bake-out collars

Some systems incorporate a bake-out collar fitted to the turbo pump to assist heating the process chamber to approximately 50°C - 60°C.

If the flow rate of the cooling water to the turbo pump is too high, the pump will be over cooled, thus reducing the heating effect of the bake-out collar.

6.9.5 Rotary vane pumps

Refer to the manufacture's literature for details of the maintenance required.

WARNING

BEFORE PROCEEDING WITH ANY MAINTENANCE WORK, READ SECTION 1 - HEALTH AND SAFETY.

6.10 Gas handling system

WARNING

BEFORE ATTEMPTING ANY MAINTENANCE WORK ON THE GAS HANDLING SYSTEM, ELECTRICALLY ISOLATE THE SYSTEM BY SWITCHING OFF AND LOCKING OFF THE WALL-MOUNTED SAFETY ISOLATION BOX. PROCESS GASES USED MAY BE TOXIC OR FLAMMABLE. ADOPT THE CORRECT PROCEDURES WITH REGARD TO PURGING BEFORE REMOVING OR LOOSENING COMPONENTS CARRYING THESE GASES. WEAR PROTECTIVE CLOTHING.

6.10.1 Wall-mounted gas pod

6.10.1.1 Annually

Ensure the gas pod and its fixings are secure.

IMPORTANT: OIPT gas pods typically weigh >40kg. Ensure the wall and gas pod fixings are sturdy enough to bear at least four times the weight of the gas pod.

6.10.2 Mass flow controllers

6.10.2.1 Annually (or as necessary)

If valves need cleaning, repair or re-calibration:

- 1) Make sure valve has been thoroughly purged before removal.
- 2) Discuss with the vendor the return of the Mass Flow Controllers for service work. Inform the vendor if hazardous gases have been used.

6.10.3 Filters

6.10.3.1 Annually (or as necessary)

The process gas filter elements will need replacing at a frequency that depends on both the nature and purity of the process gases, and of other materials that come into contact with them. The filters could need changing more or less often than annually.

- 1) Make sure line has been thoroughly purged before removal.
- 2) Unscrew union nut and remove assembly.
- 3) Tap filter element lightly on side with a fibre mallet to loosen and remove element.
- 4) Fit new element.
- 5) Re-assemble.

WARNING**BEFORE PROCEEDING WITH ANY MAINTENANCE WORK, READ SECTION 1 - HEALTH AND SAFETY.**

6.11 Pump lubricants

CAUTION

When changing or topping-up the lubricating oil in a pump, always use oil of the same brand and type. If a change of brand or type is contemplated, refer to Oxford Instruments Plasma Technology for advice.

6.11.1 General

The lubricating oils used for pumps where the oil comes into contact with the pumped gases, i.e. oil-sealed pumps such as rotary vane types, should be chosen to meet the specific characteristics necessary for the process involved.

The vapour pressure must be low at the temperatures reached at the rubbing surfaces. Viscosity should not vary significantly over the temperature range involved, and the water absorption rate and content must be low.

Lubricating oils generally fall into one of two categories: mineral (hydrocarbon) based oil or synthetic oil such as perfluorinated polyether. The synthetic oils are normally used where they come into contact with strong oxidants such as nitrogen dioxide, oxygen, or one of the halogens.

6.11.2 Perfluorised polyethers

Perfluorised polyether (PFPE) lubricants have the following properties:

- a) They are stable up to 350°C, i.e. they do not decompose below this temperature.
- b) They are chemically inert. They will, however, react with Lewis acids (BCl_3 , AlCl_3 etc.) at temperatures over 100°C.
- c) They do not polymerise under the impact of high-energy radiation.
- d) Since they tend not to keep contaminants suspended, pumps using these lubricants must always be fitted with suitable oil filters.
- e) They do not 'age' and therefore, if used correctly, need not be replaced during the lifetime of the pump.
- f) Any contaminants in the lubricant may be removed by fitting clean filters and letting the pump run for several hours with inert gas ballast, the intake port having been closed.
- g) They do not protect metal surfaces against corrosion. Pumps should therefore always be flushed with inert gas. Pumps using PFPE should be allowed to run continuously.
- h) PFPE is incompatible with hydrocarbon oils, i.e. mineral oils, conventional greases and cleaning agents.
- i) If a pump uses PFPE lubricant only Freon 113 or Frigen 113 may be used as a cleaning agent, and only PFPE grease may be employed.

WARNING**BEFORE PROCEEDING WITH ANY MAINTENANCE WORK, READ SECTION 1 - HEALTH AND SAFETY.**

- j) If it should become necessary to change from PFPE to mineral oil lubrication or vice versa, the pump must be completely disassembled, freed of lubricant and fitted with new gaskets and vanes.
- k) At temperatures over 350°C, hazardous gaseous decomposition products are formed. Therefore do not smoke in rooms where PFPE is used, and make sure that no tobacco comes into contact with PFPE.
- l) When handling PFPE, protective clothing must be used.
- m) Do not mix PFPE with used oil. Dispose of them separately.
- n) PFPE is normally odourless and colourless. Cloudiness or odour is a sign of contamination.

6.11.3 Hydrocarbon lubricants

Where mineral oils are used, the rate of oil deterioration for a particular pump and process should be established at an early stage, and oil changes based upon this information.

6.12 94-100-5-12A Cryo / heated -150 / 400C He lower electrode wafer clamping plate changeover procedure

Before carrying out a process, in the process chamber on a wafer which is a different size to that last processed, it is necessary to fit the correct type of clamping plate. Clamping plates are available for various sized wafers.

To change the clamping plate, use the following procedure (refer to Fig 6.1, page 6-20):

- 6) If necessary, vent the process chamber.
- 7) Open the process chamber lid.
- 8) Wearing powder-free gloves, unscrew the three clamping plate securing screws then remove the clamping plate from the process chamber and place on a clean surface.
- 9) Take the replacement clamping plate and mount it on the three supporting pillars then insert and tighten the three securing screws.
- 10) Close the process chamber lid.

WARNING

BEFORE PROCEEDING WITH ANY MAINTENANCE WORK, READ SECTION 1 - HEALTH AND SAFETY.

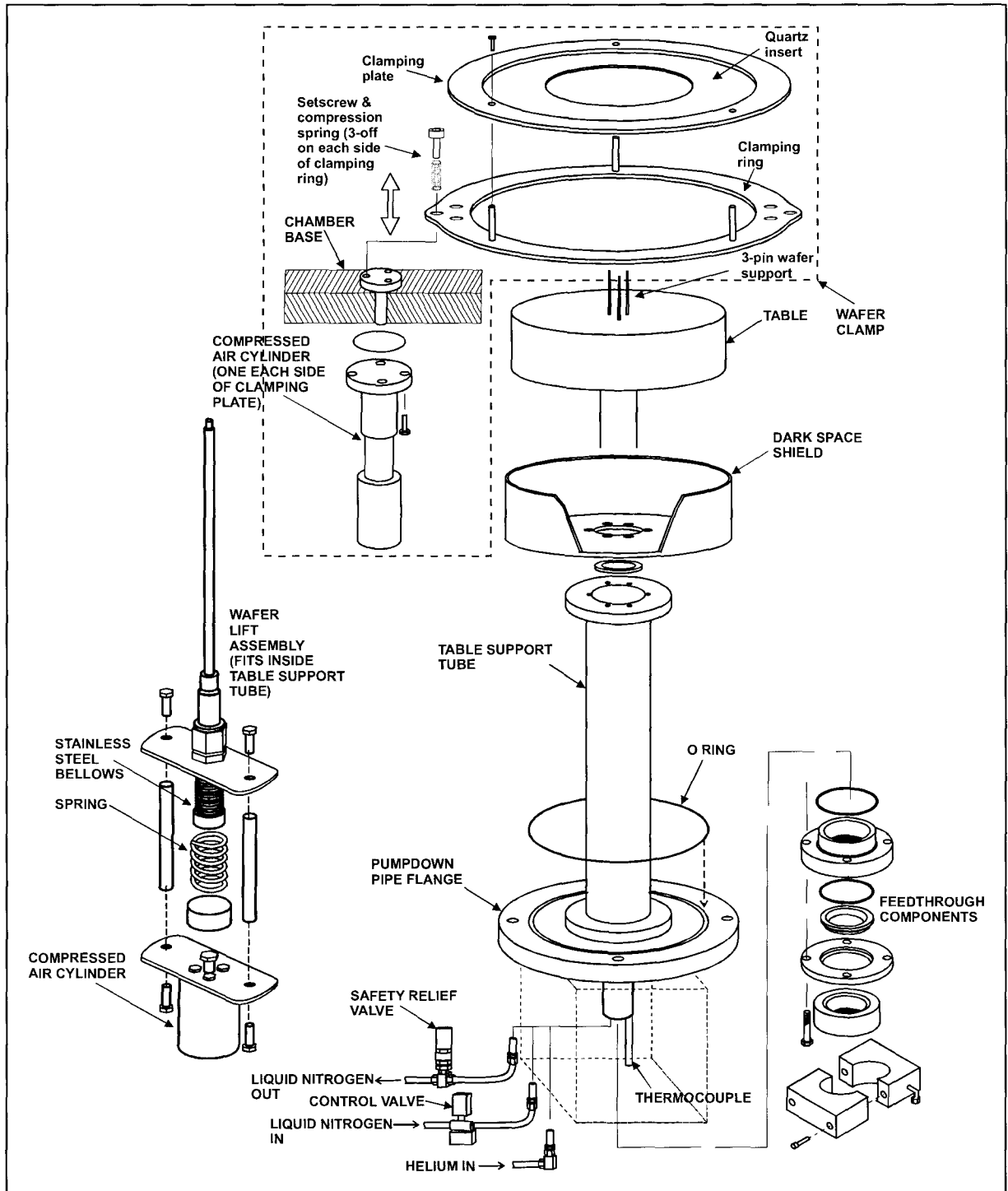

Fig 6.1: 94-100-5-12A Cryo / heated -150 / 400C He lower electrode

WARNING**BEFORE PROCEEDING WITH ANY MAINTENANCE WORK, READ SECTION 1 - HEALTH AND SAFETY.**

6.13 Adjusting the lower electrode wafer clamp clamping force

To adjust the clamping force, use the following procedure (refer to Fig 6.1 and Fig 6.2):

- 11) Open the process chamber lid.
- 12) Wearing powder-free gloves, unscrew the three clamping plate securing screws then remove the clamping plate from the process chamber and place it on a clean surface.
- 13) Using an M5 socket wrench, rotate the setscrews to adjust the length of compression springs. Ensure that all six setscrews (i.e. three at each side of the clamping ring) are rotated sequentially and equally.

NOTE: The nominal distance between the base of the clamping plate and the top of the head of each setscrew is 17mm to give a minimal clamping force. This distance can be decreased to a minimum of 10mm to increase the clamping force. Each spring gives a force of 1 Newton per mm compression, so for example, a 5mm increase in compression (i.e. reducing the distance) on each spring gives $5 \times 6 = 30$ Newtons increased clamping force.

Re-fit the clamping plate, reversing Step 2).

Close the process chamber lid.

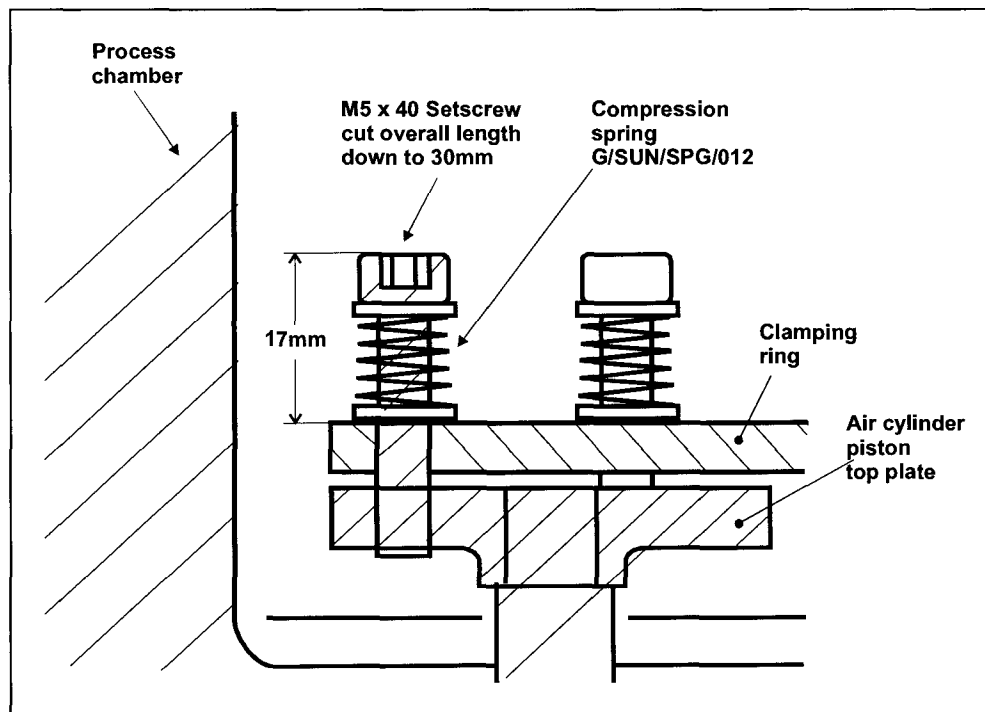

Fig 6.2: Clamping force adjustment

WARNING

BEFORE PROCEEDING WITH ANY MAINTENANCE WORK, READ SECTION 1 - HEALTH AND SAFETY.

6.14 Automatic load lock end effector adjustments for different wafer sizes

The automatic load lock end effector can accommodate wafer diameters of 3" to 8". This is achieved using a series of pairs of holes appropriately spaced for the different wafer sizes into which concentric cams are secured. See Fig 6.3.

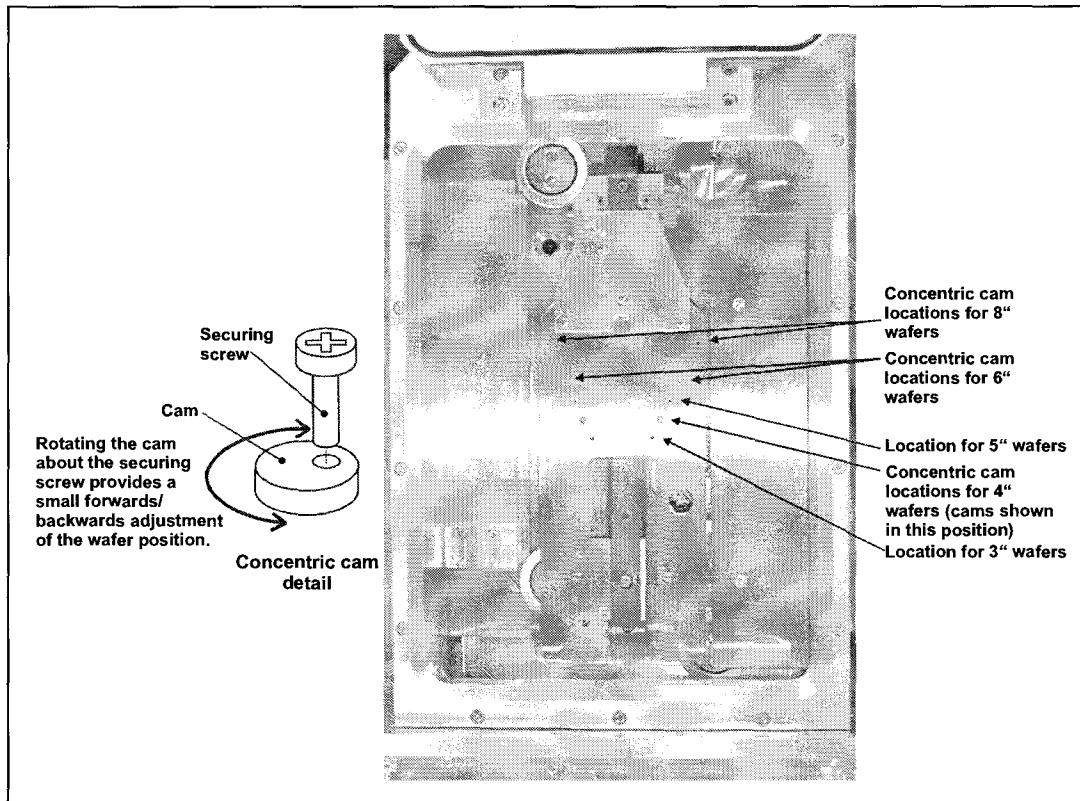

Fig 6.3: End effector wafer size adjustments

To set up the end effector for a wafer size different to that previously processed, use the following procedure:

- 1) If necessary, vent the automatic load lock.
- 2) Open the automatic load lock's lid.
- 3) Wearing powder-free gloves, remove both concentric cams/securing screws from the end effector, then fit them into the appropriate holes for the wafer size to be processed. See Fig 6.3.
- 4) Close the automatic load lock's lid, then carry out a test wafer load into a process chamber. Ensure that the wafer is located centrally on the lower electrode. If necessary, rotate the concentric cams until the wafer is located centrally.

7. Process guide & glossary

7.1 About this Section

This Section contains the OIPT 'Process Guide' document. Note that this document includes a Glossary of Terms.

Plasmalab Process Guide



Contents

1 Introduction	3
1.1 About this guide.....	3
1.2 Health and safety	3
1.3 Terminology.....	3
1.4 Document structure.....	3
2 The clean room	4
3 Processes	5
3.1 General.....	5
3.2 RIE processes	6
3.2.1 RIE operating parameter ranges	6
3.2.2 ICP operating parameter ranges	7
3.2.3 Low-pressure strike facility	8
3.2.4 DC bias.....	8
3.2.4.1 Electronegative gas mixtures	8
3.2.4.2 ICP sources	9
3.2.4.3 DC bias polarity	9
3.2.4.4 DC bias control	9
3.2.4.5 DC bias reproducibility.....	9
3.2.5 Arcing / pitting.....	10
3.2.6 Etch process chamber cleaning recipes	10
3.2.7 Sample cooling / gluing.....	11
3.2.8 Use of helium backing for effective process temperature control	12
3.2.8.1 Scope	12
3.2.8.2 Purpose.....	12
3.2.8.3 Simple Method to check Helium backing.....	12
3.2.9 Gases with low vapour pressure.....	14
3.2.10 Endpoint detection techniques	14
3.2.10.1 Optical emission spectroscopy.....	14
3.2.10.2 Laser interferometry	15
3.2.10.3 Comparison of OES and laser endpoint techniques	15
3.2.10.4 Typical OES endpoint wavelengths.....	16
3.2.10.5 Endpoint algorithm examples.....	16
3.2.11 Gas calibration factors.....	17
3.2.12 Exhaust emissions	17
3.3 PECVD processes	18
3.3.1 PECVD operating parameter ranges	18
3.3.2 Low frequency matching	18
3.3.3 Premature flaking of chamber wall / showerhead material	19
3.3.4 PECVD particles.....	20
3.3.5 Enlarging of showerhead holes.....	21
3.3.6 Optical emission endpoint detector for chamber clean process	21
3.4 Process troubleshooting.....	23
3.4.1 Partial process failure	23
3.4.1.1 Example problems	23
3.4.1.2 Typical causes.....	23
3.4.2 Total process failure	23
3.4.2.1 Example problems	23
3.4.2.2 Typical causes.....	23
4 Glossary of terms	25
5 OIPT locations worldwide	30

1 Introduction

1.1 About this guide

This guide gives information about plasma processes based on Oxford Instruments Plasma Technology's (OIPT) long experience in the semiconductor industry.

The scope of the guide is to provide a general introduction to process strategies and common process problems, and has not been prepared for a particular version of hardware. The information is presented to help users obtain optimum results from their specific process applications using Plasmalab systems.

To ensure that the information is as comprehensive and up-to-date as possible, it has been collated from the following sources within OIPT:

In-house Applications Laboratory¹ (Process Lab reports, manager's notes, customer feedback etc.)

Service Department (customer feedback, on-site experience etc.)

Technology Department (external information sources, design reviews, customer liaison, etc.)

1.2 Health and safety

For health and safety information, see Section 1 (Health and Safety) of your Plasmalab system manual.

The customer is always responsible for:

- (A) Delivery of process gases to the tool.
- (B) Removal of exhaust gases from the tool.
- (C) Maintaining a safe system of work in using and maintaining the tool.

1.3 Terminology

Material presented within this guide is aimed at users who have knowledge of plasma processes and the terms used. However, if you come across an unfamiliar term, please refer to Section 4 (Glossary of Terms).

1.4 Document structure

The text in this document is logically divided into general information and specific information relevant to the main process types (RIE and PECVD) and is generally applicable to all Plasmalab systems. Where information is only applicable to a specific system, e.g. the Plasmalab 80 Plus RIE, this is stated.

¹ The Application Laboratory is a purpose-built clean room facility housing examples of all of our Plasmalab systems for research and development purposes. Each of these systems is installed in accordance with our standard installation data documents supplied to customers for each system type.

2 The clean room

It is recommended that the OIPT process tool(s) are installed in a 'clean room' that meets the following requirements:

- HEPA filtered air conditioning system, ideally laminar flow.
- Clean room walls/ceiling/flooring constructed from low particulate materials.
- Work areas shall remain free from waste materials.
- Covered waste containers shall be provided and emptied regularly.
- Gangways shall remain clear at all times.
- Access to H&S / COSHH data sheets shall be maintained at all times.
- Access to fire protection equipment shall be maintained at all times..
- Appropriate warning labels shall be provided where required.
- Samples shall be covered where practicable, particularly at the end of a working shift.
- No eating /drinking or smoking shall be permitted in the clean room/laboratory.
- Restricted access shall be maintained and a list of authorised persons shall be displayed outside the processing areas. All other persons entering the area shall be escorted at all times.
- Items entering the processing area shall be inspected for cleanliness prior to entry.
- Non-essential items shall be precluded from the processing areas.
- Non-essential equipment or documentation shall not be stored on the floor area.
- Prior to entering the processing rooms, protective clothing shall be worn and shall constitute at least over-shoes, coat and hat. These shall be made available within the laboratory access room and will be replaced at a controlled frequency. A bench shall be provided to aid dressing with protective clothing. The bench area immediately adjacent to the entry door to the laboratory shall contain a tack mat to further prevent contamination ingress. Over shoes must not come into contact with the area that has been used for day shoes.
- Cleaning of the processing areas shall be performed with suitably filtered vacuum equipment.
- A cleaning programme shall be established and evidence of compliance maintained for audit purposes.
- All samples in current use or in temporary storage within the area shall be identified.
- Non-conforming samples shall be identified and physically segregated from acceptable work.
- Gloves shall be worn when handling unprotected samples.
- Unused tooling / equipment shall be stored in a manner to prevent damage and deterioration.
- It shall remain the responsibility of the users to ensure that tooling / equipment remains suitable for its intended purpose.

For Health & Safety guidelines, refer to Section 1 (Health & Safety) of your Plasmalab system manual.

For services required, refer to OIPT Services Specifications and the relevant Installation Data document for your Plasmalab system.

3 Processes

3.1 General

Recommendations for all systems, i.e. etch & deposition.

Day-to-day operation

- It is strongly recommended that the tools are left switched on and pumping continuously (i.e. do not switch off system or pumps). This ensures the maximum lifetime for system and pumps and optimum process repeatability.
- Datalogging of each run is strongly recommended to allow the system to maintain full records of all process runs. Items to monitor regularly via datalogs are as follows:
 - APC valve angle during process - if this is different from original/earlier data it indicates MFC and/or pumping problems.
 - RF reflected power during process - indicates matching or striking problems.
 - DC bias readings without a wafer in chamber (for etch tools only). This may identify faulty generator, loss of power in matching unit or shorting of electrode.
 - RF Automatch capacitor positions (if available) – for checking reliability of RF matching.

Weekly checks

- Leak-up rate - APC closed, measure rate of pressure rise: should be <1mTorr/minute.
- Partial pressure checks - APC fully open, measure pressure versus flow for all MFCs individually: see relevant calibration graph. This will identify problems with MFCs or pumping.
- Fill rates (if possible), i.e. measure rate of pressure rise with APC closed (can be performed using leak check software, if present), for each gas at a range of flow rates, and in particular at the flow rates of the processes in use. This may not be possible for very high flow rates (i.e. deposition processes) and is not recommended for flammable or pyrophoric gases. This will identify problems with MFCs or APC/gate valve seals.
- Pumpdown times from vent to moderate pressure e.g. 50mTorr. For example, this would be typically 18 to 20 seconds for a roots/ rotary system (e.g. standard deposition tool). This will identify problems with pumping performance. For load locked chambers, this check would be performed less frequently, e.g. only when the chamber is vented for maintenance.

3.2 RIE processes

3.2.1 RIE operating parameter ranges

For an RIE tool the typical process operating ranges are:

Total gas flows = 10 to 150 sccm. The maximum flow depends on type of pumps fitted to the system i.e. their maximum flow capacity, their pumping performance, and the required operating pressure. If you need to use a low pressure, you may have to limit the flow rate to achieve this.

Pressure = 5 to 500mTorr. Below 50mTorr, the plasma may not strike easily (or with sufficient stability) for certain gases and power levels, so you need to check this and adjust the process accordingly, since operating the system without a plasma could cause damage. This is because it is likely to cause a high reflected power, or dumping of power into the matching unit. It is always essential to check for a plasma. You can use the 'low pressure strike' feature in the software to allow easier striking for low pressure processes. For certain flow/pressure combinations, the pressure controller may have difficulty in maintaining a constant pressure, therefore this may also be a determining factor in the flow/pressure used.

RF power = typically 20W to 400W (or up to 1200W for RIE System133 or RIE 800 Plus). A plasma may not strike easily for low power levels for certain gases. You will need to check this and adjust the process accordingly, since operating the system without a plasma could cause damage. It is always important to have a cover plate (typically quartz or graphite) on the RIE electrode to protect it from sputter etch damage, particularly when operating with high RF powers and therefore high DC biases.

Helium pressure (if applicable) = 0 to 30Torr. Depends on the cooling efficiency required (some processes benefit from no cooling) and the maximum tolerable helium leakage.

Temperature is limited by the operating range of the electrode or its heater/chiller, depending on type of electrode or heater/chiller used.

NOTES:

- (A) The system base pressure will be approaching 10^{-6} Torr when measured using the Penning gauge. However, the time taken to reach this pressure will depend on whether the chamber has recently been vented to atmosphere and the cleanliness of the chamber walls. If the process chamber / electrodes are anodised, the time will increase as the anodised surfaces will take longer to outgas compared with bare metal surfaces.
- (B) Operating with chlorine-based processes can cause damage to the electrode unless it is protected with a cover plate (or dummy wafer in a tool with wafer clamping).
- (C) Operating with a high reflected power (>5% of forward power) is not advised, as this will cause damage to the matching unit or RF generator. To reduce the high reflected power, adjust the process parameters or re-tune the matching unit.

3.2.2 ICP operating parameter ranges

For an ICP 180 or ICP 380 the typical process operating ranges are:

Total gas flows = 10 to 200sccm. The maximum flow depends on type of turbo pump, i.e. its maximum flow capacity, and the required operating pressure. If you need to use a low pressure, you may have to limit the flow rate to achieve this.

Pressure = 1 to 60mTorr. Below 5mTorr and above 20mTorr the plasma may not strike easily (or with sufficient stability) for certain gases and power levels, so you need to check this and adjust the process accordingly, since operating the system without a plasma either on the substrate electrode or in the ICP tube could cause damage. This is because it is likely to cause a high reflected power, or dumping of power into matching unit. It is always essential to check for a plasma in both regions. You can use the 'low pressure strike' feature in the software to allow easier striking for low pressure processes. For certain flow/pressure combinations, the pressure controller may have difficulty in maintaining a constant pressure, therefore this may also be a determining factor in the flow/pressure used.

ICP power = approximately 200W to 2500W (or 4000W for ICP 380). The minimum power level will be dependent on how easily the plasma strikes for certain gases. You will need to check this and adjust process accordingly, since operating system without a plasma either on the substrate electrode or in the ICP tube could cause damage.

The maximum ICP power limit is set by the power rating of the RF generator. However, most processes perform well with only moderate ICP power levels. This also helps to avoid excessive substrate heating.

Substrate electrode RF power = typically 5W to 400W. A plasma may not strike easily for low power levels for certain gases. You will need to check this and adjust the process accordingly, since operating the system without a plasma either on the substrate electrode or in the ICP tube could cause damage.

Helium pressure = 0 to 30Torr. Depends on the cooling efficiency required (some processes benefit from no cooling) and the maximum tolerable helium leakage.

Temperature is limited by the operating range of the electrode or its heater/chiller, depending on type of electrode or heater/chiller used.

NOTES:

- (A) The system base pressure will be of approaching 10^{-6} Torr or better when measured using the Penning gauge. However, the time taken to reach this pressure will depend on whether the chamber has recently been vented to atmosphere and the cleanliness of the chamber walls. If the process chamber / electrodes are anodised, the time will increase as the anodised surfaces will take longer to outgas compared with bare metal surfaces.
- (B) Operating with chlorine based processes can cause damage to the electrode unless it is protected with a dummy wafer.
- (C) Operating with a high-reflected power (>5% of forward power) is not advised, as this will cause damage to the matching unit or RF generator. To reduce the high-reflected power, adjust the process parameters or re-tune the matching unit.

3.2.3 Low-pressure strike facility

"Low pressure strike" is a necessary software facility, since for low pressure RIE or ICP processes, the concentration of free electrons being produced simply isn't high enough to start and maintain the ionisation 'chain reaction' or avalanche which is required to initiate the plasma. So it is necessary to use higher pressures during the first few seconds of the process step. The software therefore allows the operator to raise the pressure briefly at the start of the plasma process to enable the plasma to strike.

This does not cause any problems for the processes involved, because the time taken to strike the plasma at the higher pressure is very short, and will be a very small percentage of the total process time.

3.2.4 DC bias

With any plasma etch system it is important to remember that DC bias readings can be affected by surface coatings on the lower electrode. These can include:

- (a) Quartz cover plate (or any other insulating cover plate material),
- (b) Electrode surface anodisation,
- (c) Polymer coating on electrode surface generated by process,
- (d) Any other insulating coating generated by plasma.

In all of these cases, the DC bias reading will be inaccurate due to the lack of DC contact to the plasma. Quite often, the measured DC bias will be close to zero if there is a complete insulation of the electrode or if the process conditions are such that there is minimal contact between the exposed areas of the electrode and the plasma.

This is not to say that the sheath potential (or ion energy) has actually reduced to zero; in fact it has not changed at all from the non-insulated case. It is simply that the measurement of this value via DC bias is no longer possible. It is also quite common in these cases for the DC bias reading to vary sharply throughout the run.

It is therefore recommended that the DC bias for a particular process condition be measured with a bare electrode (e.g. prior to loading the quartz cover plate). In load locked single wafer systems, it is necessary to measure the DC bias without a wafer loaded, as this will expose the central wafer lift pin to provide accurate DC bias measurement.

This is the only way of obtaining a reliable/stable DC bias measurement.

If the electrode is anodised, it may also be necessary to ensure that the wafer lift pin is exposed and clean as this will be the only conductive path for the DC bias measurement. If there is no wafer lift pin (e.g. RIE 80 Plus), it may be necessary to use the central locating pin for the DC bias measurement or even to scratch away a small area of anodisation.

If it is suspected that there has been polymer deposition on the electrode, it may be necessary to clean off the polymer (with an O₂ plasma or by mechanical cleaning) to allow an accurate measurement of the DC bias.

3.2.4.1 Electronegative gas mixtures

Strongly electronegative mixtures, such as SF₆ gas above 10 Pa (70 mTorr), may give close-to-zero DC bias. This is not a fault, but is due to the formation of negative ions in the plasma. A DC bias exists only because of the difference in mobility between the negative and positive charges in a normal plasma. When both charge carriers are heavy ions, the plasma does not rectify and the dc bias collapses.

3.2.4.2 ICP sources

The DC bias on the lower electrode can be a strong function of the power in any auxiliary plasma source, for a fixed lower electrode RF power. At low ICP power, there can be a rise in DC bias reading, because of the increase in the effective area of the grounded electrode. As the ICP power rises, the DC bias is reduced, as ions from the source begin to dominate the ion flux at the electrode. This reduction in DC bias is a good sign of plasma from the source reaching the lower electrode.

3.2.4.3 DC bias polarity

The surface of the RF driven electrode takes a negative bias with respect to the plasma. However, the literature and the industry tend to refer to DC bias as a positive quantity, and we follow this convention in our equipment.

3.2.4.4 DC bias control

The DC bias value will depend on all the process parameters and several aspects of the machine condition. When the DC bias value is important to the correct operation of the process, it is often possible to use DC bias as the recipe parameter, and have the RF bias power as a free parameter. The control mode (power or bias) is selectable on the PC screen where this feature has been provided. However, if you are planning to use DC bias control mode, it is worth noting the points raised in the preceding sub-sections about potential causes of inaccuracies / variability in DC bias readings.

3.2.4.5 DC bias reproducibility

DC bias is a very sensitive indicator of the state of the plasma tool. While this makes it a useful parameter to measure and record, it also makes it difficult to ensure that the value is consistent from day-to-day on the same machine, and between nominally identical systems.

It is occasionally requested that the DC bias reading is adjusted to make the reading the same across different tools, but we have taken the view that it is better to know the actual value.

The main hardware causes for DC bias changes are:

- (a) Electrical conductivity of the cooling medium for the electrode or automatch. Check this by running briefly with the cooling fluid removed completely. Shifts in DC bias between dry and cooled states of up to 5% are common. A shift of more than 10% indicates the fluid is too conducting.
- (b) Inadequate cooling of a fluid-cooled automatch. This is sometimes linked with fluid conductivity, with an electrochemical reaction depositing material in the stainless steel bulkhead fitting of the automatch.
- (c) Changes in dark space shield distance. If the table is not seated correctly, the shield gap changes and the DC bias value is altered
- (d) Oxidation of components in the RF delivery path. The connection between the automatch and the electrode carries several amperes of RF current. The connection must be sound, or it can become heated, with a progressive addition to the losses
- (e) Loss of the ground path. RF current driving the plasma flows in a closed loop circuit. High resistance or breaks in the ground return path will alter the DC bias – but usually manifest themselves first as RF interference problems. Pay particular attention to any straps securing the dark space screen, the RF shielding under the lower electrode, and the mounting of the automatch.

3.2.5 Arcing / pitting

Arcing around the showerhead could be related to:

- (a) Contamination of the showerhead / chamber walls (e.g. insulating/polymer coating, backstreaming of pump oil or excessive use of vacuum grease on o-rings).
- (b) A fault in the matching unit, more specifically the DC bias measurement circuit. Running at high bias for extended periods can potentially cause damage to the DC bias measurement circuit which can lead to a change in electrode performance and increased plasma potential causing sparking on grounded walls. DC bias readings are also greatly reduced by this fault.

It may be worth manually scrubbing the showerhead and then trying again. If you are still seeing sparking then it is worth investigating the matching unit.

3.2.6 Etch process chamber cleaning recipes

There are a number of plasma clean strategies currently in use:

- (a) For polymer processes (any process containing C_4F_8 , CHF_3 , or CH_4 , e.g. C_4F_8/O_2 , CHF_3/Ar , CH_4/H_2 , CHF_3/Ar) we use an O_2 based etch to remove the polymer. The rate can often be increased by adding 10-20% SF_6 , - this is more common in cleaning recipes for ICP chambers.

Typical examples are:

RIE chamber:

O_2	100 sccm
Pressure	100mT
Electrode	200 W
Time*	1-2 hours, but dependent on total process time since last clean
Period*	After every 3-10hours etching

* These parameters are dependent on process gases, conditions and chamber wall temperature, so are subject to change

ICP chamber:

O_2	40 sccm
SF_6	10 sccm (optional, if not available)
Pressure	20mT
ICP Power	1500 W
Electrode	150 W
Backside He	0 mbar
Time*	1-2 hours, but dependent on total process time since last clean
Period*	After every 3 to 10 hours etching

* These parameters are dependent on process gases, conditions and chamber wall temperature, so are subject to change.

- (b) For processes which deposit an inorganic film, e.g. a-Si, SiO_2 , BO_x etc from $SiCl_4$, or BCl_3 it may be necessary to use a more chemical process, e.g.:

SF_6	50 sccm
Pressure	20mT
ICP Power	1500 W
Electrode	150 W
Backside He	0 mbar

- (c) For processes which deposit a combination of etched material and mask layer, e.g. GaAs and sputtered photoresist during GaAs 'via hole etching' it is common to use a mixed Chlorine/fluorine chemistry:

RIE chamber:

SF₆ 85 sccm
Cl₂ 50 sccm
Pressure 45mT
Power 150W
Temperature 20 C
Quartz carrier plate

ICP chamber:

Step1: 40sccm Cl₂, 20sccm SF₆, 50mT, 500W ICP, 200W RF, 22C, 0Torr He, 20mins to remove GaAs and PR residues (may need to be longer after lots of 'via hole etching').

Step2: 50sccm O₂, 20mT, 2000W ICP, 200W RF, 22C, 0Torr He, 30mins

Step3: 50sccm O₂, 60mT, 2000W ICP, 200W RF, 22C, 0Torr He, 30mins

3.2.7 Sample cooling / gluing

It is quite a common requirement to process small samples or pieces of wafer. If the process requires cooling to improve the etch profile or to allow use of resist mask at high power levels, then the small pieces of wafer must be glued/fixated to a carrier wafer which is clamped and helium cooled. There are several ways of attaching the small pieces of wafer to the carrier:

- (a) Vacuum grease (after etching has been completed the vacuum grease can be removed from back of wafer using IPA or acetone).
- (b) Thermal compound.
- (c) Photoresist (i.e. spin a few microns of resist onto a carrier wafer, place the sample on top while the resist is still wet, push sample down well into resist, and then bake resist).
- (d) Use a thermally conductive elastomer pad (see [EMI Shielding and Thermal Management Solutions](#)).

With methods (a), (b) and (d) it is important that the sample completely covers the bonding material, so that no bonding material is exposed to the plasma and therefore cannot be re-deposited on the wafer.

With all these methods it is necessary to also clamp the carrier wafer and apply helium pressure to the back of the carrier wafer to provide cooling to the sample (there is no cooling effect simply from gluing the sample to the carrier if there is no cooling of the carrier).

If the process does not need cooling (as with most low power RIE-only processes) then it is not necessary to bond the sample to carrier. If the sample is liable to slide off the carrier during transfer, it is often better to glue pieces of Si to the carrier wafer to act as locating pieces to hold the sample in place. This avoids the need to glue the sample and therefore keeps the sample cleaner.

3.2.8 Use of helium backing for effective process temperature control

3.2.8.1 Scope

For all systems with wafer clamping and helium backing for wafer temperature control. i.e. Plasmalab System 100 with ICP 65, 180 and 380 sources. Also, occasionally RIE 133 systems and RIE 80 Plus.

3.2.8.2 Purpose

It is important to ensure that the helium is sealed adequately behind the wafer. If the helium is leaking out past the wafer with a poor seal against the table, the thermal contact to the temperature-controlled table will be degraded. The wafer will then heat up more than expected and the process results may suffer. For example, in SiO₂ etching the profile may become partially isotropic and/or any photoresist masking used may burn too easily.

3.2.8.3 Simple Method to check Helium backing

- (a) If the wafer is sealing the helium effectively, the measured He flow will be less than that when no wafer is present.
- (b) Set a range of He pressures and note the measured helium flows with no wafer loaded. (Set all process gases, RF and pressure to zero and work in 'manual' mode.)
- (c) Load a blank Si wafer of the correct size (if the system is a standard single wafer type) and note the He flows for the same range of set He pressures.
- (d) Load a typical customer wafer (e.g. with a thick SiO₂ layer) and note the He flows for the same range of set He pressures. If a carrier is appropriate for the system, use that.
- (e) Fill results in the following table. (If you do not have the capability to measure Helium flow then measure CM gauge chamber pressure with APC fully open, no other gases flowing).

Set He/Torr	He flow/sccm No wafer	He flow/sccm Si wafer	He flow/sccm Customer wafer
7			
10			
15			
20			

- (f) The larger the difference between 'No wafer' and 'With wafer' flows, the better the seal. 'With wafer' values should be less. Pass criteria are still being evaluated but a recent example with acceptable results is as follows.
- (g) Recent acceptable example:

Set He pressure	No wafer He flow	With wafer He flow*
7Torr	4.2sccm	<3.9sccm
10Torr	7.2sccm	<6.5sccm

*These were the maximum values observed (usually occurring for wafers with thick SiO₂ layers) and cooling was thought to be adequate because profiles were acceptable.

If there is little or no difference between the 'No wafer' and 'with wafer' flows, then the seal is ineffective.

(h) Troubleshooting:

Check the backs of wafers for excessive contamination, scratching or curvature/bowing. Vent chamber and check electrode for particles, scratches, or erosion. Check wafer clamp integrity and wafer clamping force i.e. can you move the wafer by finger pressure when clamped?

Compare results with blank Si if possible. If blank Si is OK, there is a problem with the customer wafers, i.e. they are warped or too flexible or too thin (thin wafers may require reduced He pressure to avoid flexing of wafers), or the clamp ring does not have sufficient clamping points to maintain wafer flatness.

Also check that the measured He pressure is correct – if the Helium pressure gauge is faulty, the actual pressure could be far too high. Typical CM gauge pressure when wafer is clamped and helium pressure applied (APC fully open and no other gases flowing) is in the range 0.3-2mT for the range of Helium pressures given above.

For the range of helium pressures given previously: Typical CM gauge pressure when the wafer is clamped and the helium pressure applied (with the APC fully open and no other gases flowing) is in the range 0.3mTorr to 2mTorr.

Checks with the system vented:

- (1) Ensure that the electrode is very flat and clean (no bumps or grooves eroded into it) and that the back of the wafer is clean and smooth (no resist or glue or anything else adhering to the back), and is mechanically strong so that it does not buckle or bow.
- (2) Check that the wafer lift star (or pins) retracts fully below the surface of the electrode. This can be checked with a flat edge placed on top of the star - if it wobbles then the star is too high. If the star sticks up above the electrode, the helium will escape and the cooling efficiency will be severely reduced (also, because of the increased gap between wafer and electrode surface, which needs to be a few tens of microns for best cooling).
- (3) Check that the clamping ring is actually clamping the wafer to give maximum clamp force. Often, there can be a discrepancy between the wafer clamp recess height and the wafer thickness, meaning that the wafer is not clamped and 'rattles' about inside the clamp ring. The clamping force should therefore be adjusted as described in Section 6. of the system manual.

You should try to move the wafer with your finger, if you can move it then it is not clamped properly and you may need to temporarily modify the ring by adding strips of PTFE or aluminium foil to make it press down on the wafer.

- (4) The wafer should be placed centrally in the clamp ring.
- (5) Press down on the wafer in various places and see if it moves. This will indicate that the wafer is not sitting down flat on the electrode. Try polishing away any bumps.

Checks with the system under vacuum:

- (1) A good test of whether the wafer is being clamped properly is to measure the helium pressure in the chamber (measured on CM gauge) both with and without a wafer in place for a variety of helium pressure setpoints.

There should be a clear difference between helium pressure with and without wafer. If there is no difference then it indicates that there is a helium leak caused by incorrect clamping.

- (2) The helium setpoint should be set so that there is 1-2 mTorr chamber pressure with a wafer in place. This ensures that there is sufficient cooling. It is probably best to work at as high a level as you can tolerate if there is any doubt over cooling efficiency.

3.2.9 Gases with low vapour pressure

Gases with a low vapour pressure (e.g. SiCl_4 , BCl_3) present unique problems for the gas supply system, e.g. temperature dependence of gas pressure, condensation in the gas lines, and low line pressure.

To avoid the loss of line pressure during cold weather, it is recommended that gases with a low vapour pressure are sited indoors, inside an extracted gas cabinet. However, it is NOT recommended to deliberately heat the gas cylinder (e.g. by using a heated jacket) as this will result in the re-condensation of the gas in the gas line and/or MFC, since these areas are likely to be cooler than the cylinder. The presence of condensed gas in the gas line or MFC will cause loss of flow or severe pulsing of measured gas flow.

Note that condensation problems can sometimes be observed even without direct cylinder heating. This is usually due to a slight temperature difference between cylinder and MFC. In such cases, it is recommended that heating tape is placed around the MFC, filter and valve assembly of the gas line to ensure that the MFC and other components are kept at a higher temperature than the gas cylinder. An alternative solution would be to use a heated MFC.

3.2.10 Endpoint detection techniques

3.2.10.1 Optical emission spectroscopy

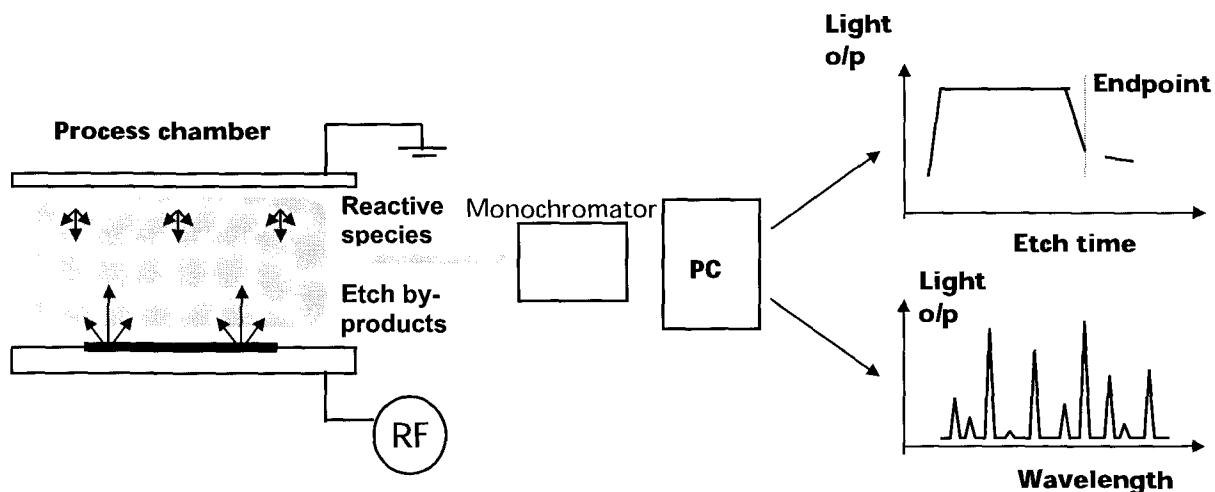

- Monitoring of reactive species or etch by-products provides endpoint signal.
- Endpoint relies on etch stop layer.
- Scanned monochromator allows full spectrum analysis.

3.2.10.2 Laser interferometry

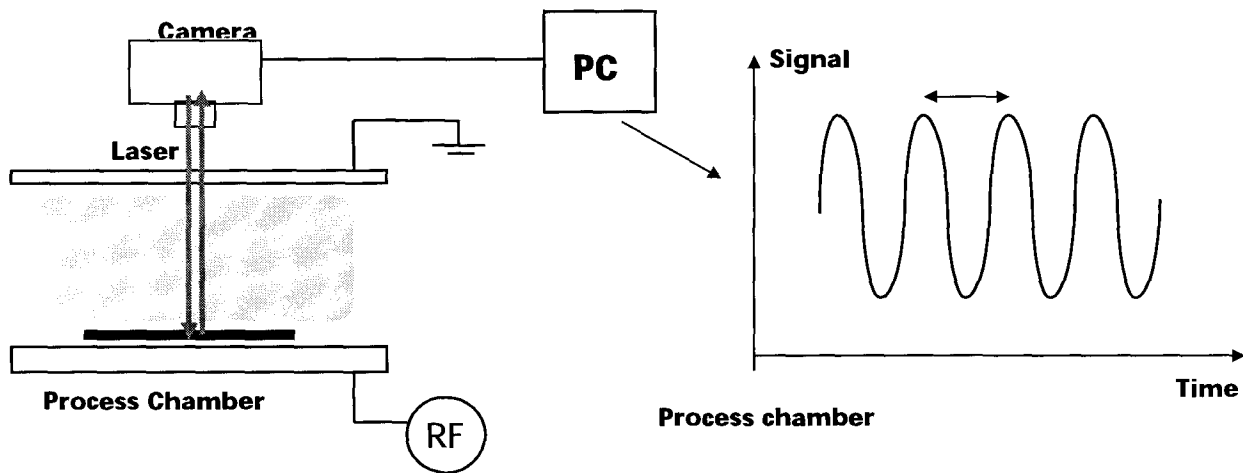

- In-situ etch rate monitoring
- Endpoint does not require etch stop layer
- Endpoint can be chosen anywhere within the layer once etch rate has been established.

3.2.10.3 Comparison of OES and laser endpoint techniques

A laser interferometer (LI) endpoint system has the benefits that it gives very precise measurement of etch depth in the etched layer or layers and can be used on very small pieces of wafer.

It works best with a flat transparent layer (or stack of layers) on a reflective substrate.

It can be used to determine when the etch reaches an interface between differing materials (by detecting a change in slope of the laser reflectance signal with time), or can measure the etch depth when partially etching through a layer (by counting interference ripples).

It can also often be used to identify multiple interfaces when etching through different layers in a multi-layer stack of materials (through the changes in reflectance of the materials in question).

The disadvantage is that the laser spot needs to be aligned every time to a suitable measurement point on the wafer (i.e. an etched area, not a masked area). Also, it only measures a single point, so any process non-uniformity will result in a range of etch depths across-wafer or across batch.

The optical emission spectroscopy (OES) system has the benefit that it does not require alignment for every run, it simply looks at optical emission from the whole plasma. This however, means that it needs larger wafers or a larger etched area (>2cm²) to effectively determine endpoint. The size of the etched area needed for good OE endpoint is also dependent on the materials being etched since the emission lines for certain materials can be very faint. Also, if the etch rate of the material is low then the concentration of its etch species will be low.

OE can only detect a change in the strength of a particular emission line (or group of emission lines), so can only detect when the etch passes through an interface between differing materials.

OE can give a qualitative idea of uniformity, since the length of the transition of the signal from before endpoint to after endpoint will indicate the quality of the etch uniformity. Also the endpoint is more accurate for the whole (average) of the wafer rather than a single point on the wafer.

3.2.10.4 Typical OES endpoint wavelengths

Material etched	Gas species detected	Wavelength nm	Rise/fall at endpoint
Si	F	704	Rise
Si	SiF	440, 777	Fall
Si	SiCl	287	Fall
SiO2	F	704	Rise
SiO2	CO	483	Fall
Resist, polyimide	O	843	Rise
Resist, polyimide	CO	483	Fall
Resist, polyimide	OH	309	Fall
Resist, polyimide	H	656	Fall
Si3N4	N2	337	Fall
Si3N4	CN	387	Fall
Si3N4	N	674	Fall
W	F	704	Rise
Al	Al	391, 394, 396	Fall

3.2.10.5 Endpoint algorithm examples

Endpoint trace - (signal, falling)

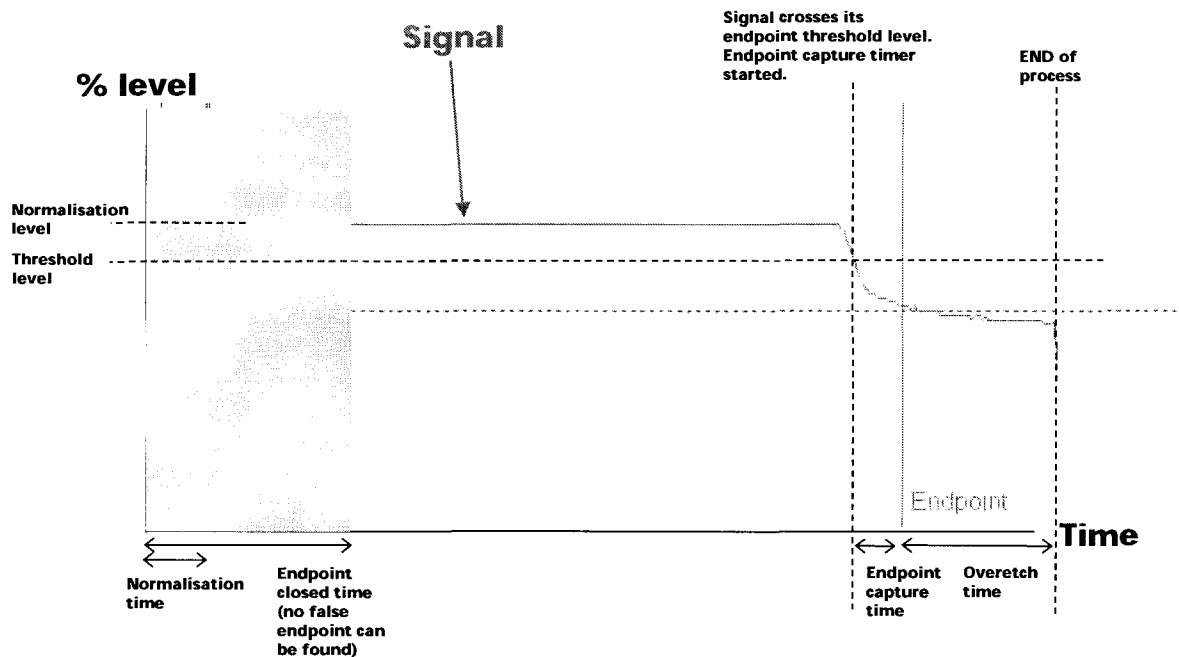

Endpoint trace - (derivative, less than)

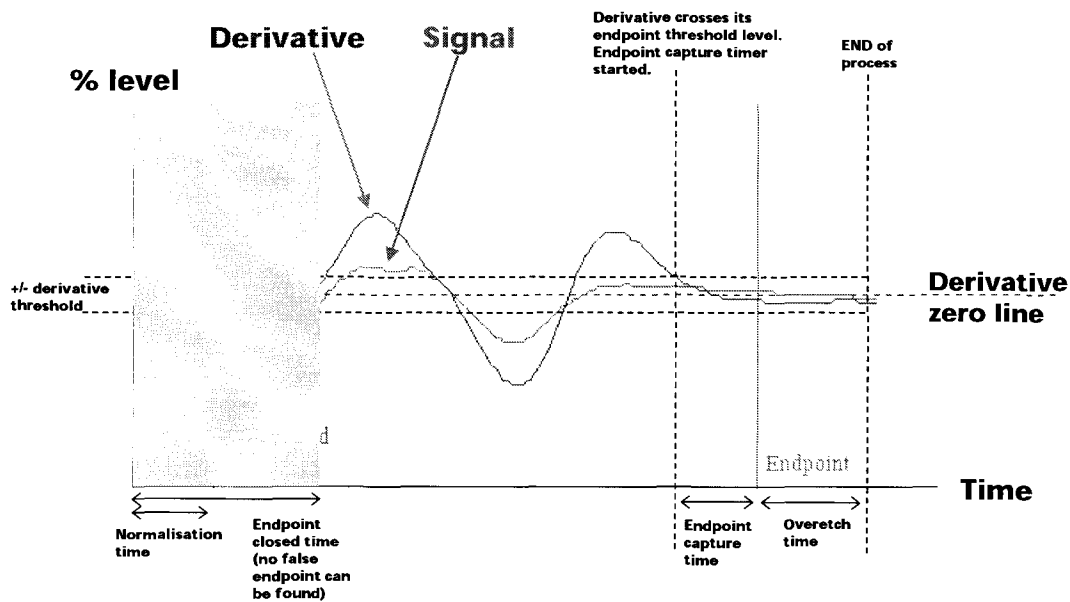

3.2.11 Gas calibration factors

See the MKS OEM manual for details of gas correction factors. However, it is worth pointing out that for certain gases (e.g. H₂ or He) it is recommended that the MFC is calibrated for that particular gas, since they have very different gas properties compared to other gases, and hence the errors on calibration factors is large.

3.2.12 Exhaust emissions

The gas emitted by a plasma etch process will be mostly made up of the input gases. However, there will be a small but significant component of etch or plasma by-products (say up to ~10% in an RIE tool, possibly more for ICP). The exact amounts will depend on process type and conditions. These can be any combination of etch gas material and etched material.

For example:

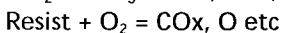
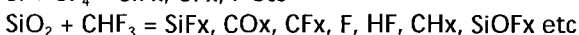
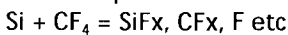

As many of these by-products are toxic, it is a minimum requirement that these gases are exhausted in an enclosed extraction system to the roof of the building - following health and safety regulations. In addition to this, depending on local regulations, it may be necessary to have some form of gas scrubbing before releasing these materials to the atmosphere.

Even if we were not running gases through the system, we would recommend that the system exhaust is extracted correctly, since the pump exhaust will contain small droplets of pump oil which are in themselves harmful to lung function.

Another important consideration is the gas absorbed in the pump oil. Since the exhaust gases contain HF there will be a build up of HF in the pump oil. Therefore, it is important to use the correct protective equipment when servicing the pump or changing pump oil, i.e. suitable gloves, protective clothing, filtered facemask or breathing apparatus.

It is also worth remembering that when using O₂ processes the pump oil should be Fomblin oil and NOT mineral oil to avoid risk of fire or explosive reaction between O₂ and mineral oil.

3.3 PECVD processes

3.3.1 PECVD operating parameter ranges

For a PECVD tool the typical process operating ranges are:

Total gas flows = 150 to 3000scm. The maximum depends on the type of pumps i.e. their maximum flow capacity, their pumping performance, and the required operating pressure. If you need to use a low pressure, you may have to limit flow rate to achieve this.

Pressure = 200 to 2000mTorr. Below 300mTorr the plasma may not strike easily (or with sufficient stability) for certain gases and power levels, so you need to check this and adjust process accordingly, since operating the system without a plasma could cause damage. This is because it is likely to cause a high reflected power, or dumping of power into matching unit. It is always essential to check for a plasma. You can use the low pressure strike feature in the software to allow easier striking for low pressure processes. For certain flow/pressure combinations, the pressure controller may have difficulty in maintaining a constant pressure, therefore this may also be a determining factor in the flow/pressure used.

RF power = typically 20W to 300W. A plasma may not strike easily for low power levels for certain gases. You will need to check this and adjust process accordingly, since operating system without a plasma could cause damage.

Temperature = room temperature to 400C (or up to 700C for a 700C stainless steel electrode). Film quality/density will be worse at lower temperatures, therefore, it is recommended to operate at the maximum temperature that the substrate will allow for best film properties.

The system base pressure for PECVD chambers is often measured simply by using the CM gauge, hence base pressures are typically a few mTorr. The exact value is mainly determined by the offset of the CM gauge zero (this is usually set slightly positive by a few mTorr to ensure a sensible reading, since a negative offset will always read zero).

Operating with a high reflected power (>5% of forward power) is not advised as this will cause damage to matching unit or generator. In such cases it will be necessary to adjust process parameters or re-tune the matching unit.

3.3.2 Low frequency matching

The uniformity of nitride films is usually worse for Low Frequency (LF) deposition since the LF is closer to DC and hence is much more sensitive to the electrical conductance from electrode to plasma, and from plasma through wafer and back to ground. So if the chamber and/or table are dirty then there is likely to be more non-uniformity in the LF film.

It is recommended that when performing an LF or mixed frequency deposition, that the customer should do a brief conditioning of a few thousand angstroms, and then endeavor to keep that constant thickness of film on the table under the wafer throughout the subsequent runs. This means putting dummy wafers or Aluminum blanks over the unused wafer position to avoid a build up of film in the unused locations, because it is known that these locations will give a very poor uniformity if this procedure is not carried out.

If this does not cure the problem then it may be that the system needs a thorough clean, back to bare Aluminum. Initially, using a plasma clean, but if that doesn't work, a bead-blast of the showerhead or the table may be required.

It is not recommended to use an IPA or water wipe-down of the chamber interior, - just an occasional dry wipe-down, if necessary, to remove loose powder. This should only be done with the system stone cold (to avoid melting/residues of clean room wipes on hot surfaces).

Another possible cause of non-uniformity is wafer material - GaAs is less conductive, so large GaAs wafers show more non-uniformity, which can be counteracted to some degree by increasing the LF frequency, but there is a trade-off with matching (i.e. reflected power is generally higher at higher frequency). (To adjust the frequency, Press the Program button - adjust the Frequency - press the Program button again to run at the new frequency).

For LF power, the PC should be setting (and the generator should be controlling) load power as this is the power that actually reaches the plasma. The matching is often quite bad for LF, but this doesn't matter too much as the LF generator increases its power output to compensate and to ensure that the power delivered to the load (load power) is always as requested.

However, it is advisable to adjust the step-up transformer to minimize reflected power, to avoid overheating of the LF generator, especially as the RFPP generators will switch themselves off automatically if reflected power is above 40-50W for self-protection.

3.3.3 Premature flaking of chamber wall / showerhead material

Premature flaking of chamber wall / showerhead material can occur for a number of reasons:

- 1) For new systems the showerhead may need several deposition/clean cycles before it reaches its best film adhesion performance. This can be improved by bead blasting the showerhead.
- 2) Temperature cycling of showerhead / chamber walls can cause flaking, therefore it is important that chamber walls are set to a stable temperature, e.g. 60C, and that the showerhead cooling water is flowing properly. It is also important that electrode temperature is maintained at a constant value as this will also affect showerhead temperature.
- 3) The system should not be switched off overnight to save power. The system should be left pumping with electrode maintained at deposition temperature at all times to avoid flaking.
- 4) Incomplete cleaning during a previous clean cycle can lead to premature flaking.
- 5) Wiping of chamber and or showerhead with water or IPA can leave residues which subsequently causes early flake-off of films deposited.
- 6) Wiping of chamber walls / showerhead with clean room wipes while they are hot can also leave behind residues which cause premature flaking.
- 7) Repeated venting of chamber will cause flaking. This one of the main reasons that for a PECVD 80 Plus or a PECVD 800 Plus, it is recommended to clean every 5-10 microns of film, whereas for a load locked PECVD System 100 running high rate SiO₂ films, it is not necessary to clean as often.
- 8) Mixed deposition of oxide, nitride, and oxynitride films can cause increased stresses in deposited films and hence premature flaking.
- 9) Changes to standard recipes can also cause increased stress and hence premature flaking.

For a PECVD System100 running high rate oxide we recommend plasma cleaning every 100microns for best film repeatability. A dry wipe of showerhead and vacuum cleaning of any large particles may also be required.

For a PECVD 80 Plus or PECVD 800 Plus, it is recommended to clean every 5-10microns of film. Plasma cleaning may need to be carried out more often if mixing depositions or using a range of electrode temperatures etc as listed above. A dry wipe of showerhead and vacuum cleaning of any large particles may also be required.

3.3.4 PECVD particles

Please note that once particles have been noticed, all wafers should be examined under a strong light source at various angles of incidence, say a microscope light source, to really be sure there are no particles still present in the wafer. This is by no means a comprehensive list of all the particles, which can occur in a PECVD process chamber, but is intended as a helpful guide to quickly eliminate the common problems.

Particle descriptions	When they most often occur	Possible causes	Remedy/Quick Fix -Test
<p>Small particles less than 5µm, which appear in concentrated, clusters. These clusters appear in a pattern, which mirrors that of the showerhead holes.</p> <p>They are concentrated mainly in one focal plane of the microscope and appear to be at the bottom of the film.</p>	The first run after a clean	Running the machine too soon after the completion of a clean process. Silane forms particles when it reacts with residual oxygen in the gas lines (remember all of the gas line up to the normally open, hardware interlock nupro valve is incorporated in the chamber vacuum and needs to de-gas at the end of a long clean run).	Wait 30 minutes before running a deposition process using Silane after finishing a clean. Or run pump/purge cycles with N2 gas.
<p>Small particles less than 5µm, which appear in concentrated, clusters. These clusters appear in a pattern, which mirrors that of the showerhead holes.</p> <p>They are concentrated mainly in one focal plane of the microscope and appear to be at the bottom of the film.</p>	The first run after a long period of machine disuse (say overnight)	A small leak in the Silane line, particularly around the mass flow, allowing a build-up of Silane dust, which is blown though on to the first wafer.	Fix the leak in the Silane line. Flow Silane gas after a significant period of machine disuse without a wafer in the chamber to clear the dust.
<p>Small particles less than 5µm, which appear in concentrated, clusters. These clusters appear in a pattern, which may or may not mirror that of the showerhead holes.</p> <p>They appear in many different focal planes of the microscope, at regular intervals throughout the film.</p>	Every run	<p>A leak in the gas in-let assembly or a severe leak in the Silane line.</p> <p>Plasma forming behind the showerhead or in the gas inlet assembly.</p>	Leak check chamber and gas line. If both less than 1mT per minute contact Oxford service department and give this description. If greater than 1 mTorr per minute take apart gas inlet assembly and clean O-rings and PTFE part.
Flakes or larger non-metallic particles	First run after a clean	Residual particles not etched during the cleaning process	Vacuum the chamber inside, this is necessary periodically after cleaning. It may be a good idea to cool the chamber first to prevent risk of injury with the hot table.
	After a power failure or other reason which caused a significant drop in table temperature	When the lower electrode cools deposited film, particularly around the edges, cracks and is blown on to the wafer during subsequent deposition runs.	Clean the chamber.
	After a certain amount of deposition on the chamber, but it varies when they occur.	If you are depositing films of many different chemistries and stresses, particularly those with high stress, then the film will flake off much earlier than expected.	Clean more regularly.
	After a certain amount of deposition but it seems to be getting less and less after every clean.	The films are not adhering to the showerhead very well. Someone has cleaned the showerhead using solvent, leaving behind a residue that is giving poor adhesion for the deposited films. The showerhead has become dirty and the clean process is unable to clean it – the showerhead is ready for its periodic maintenance.	Bead blast the showerhead.
Metal particles, which shine under normal clean room light and are greater than 20µm in maximum dimension.	Mostly all the time	Showerhead holes may be lighting-up or the showerhead holes have become damaged due to normal wear and tear.	Bead blast the showerhead.

Particle descriptions	When they most often occur	Possible causes	Remedy/Quick Fix -Test
Particles or marks, which appear randomly on the wafer, but look as if they are underneath the film.	Every run	The wafer has been cleaned using solvents, which have not been properly washed off with de-ionised water.	Use a fresh wafer straight from a new box.

As part of the regular maintenance of the system the showerhead (and doughnut ring) must be bead blasted. This is the only Oxford Instruments Plasma Technology approved way of cleaning a showerhead. The use of solvents and ultra-sonic baths is strongly discouraged. Scrubbing with Scotchbrite is also not recommended. OIPT will not be able to support you if you use these alternative cleaning methods and still experience problems the problems described in the above table with showerhead particles.

Recommended bead blasting specification:

Bead blast using alumina powder (aluminium oxide beads) of 180 grit size or less - maybe 120. Do not use any solvents. Clean the showerhead after bead blasting using compressed air only. Hold the showerhead up to the light to check that none of the holes are blocked by any grit from the bead blasting. Clean out holes with paper clip or similar if blocked.

3.3.5 Enlarging of showerhead holes

PECVD showerhead holes can become enlarged during use. This is caused during high-power processing (on an 80 Plus this is typically during plasma cleaning). Any holes, which have slightly sharper edges, will form an intense discharge over the hole (due to the high fields generated by the sharper edges). This can be seen as a 'bright spot' in the plasma located over the hole during the clean process.

This can cause some erosion of the hole and widening of the hole opening (on the outlet side only). Eventually, the bright spot burning itself out, i.e. the erosion removes the sharp edges and hence the bright spot no longer occurs at that hole. This may happen for several holes during the initial run-up of the system, until the showerhead 'stabilises' itself.

The bright spot may also result in some black/brown polymer deposition around the holes which, can cause premature flake-off of deposited films. It is recommended that the showerhead is bead-blasted clean to remove such residues.

The bright spots should not be observed during low power (<50W) 80 Plus deposition processes. If they are, it is recommended that the showerhead is plasma cleaned and bead-blasted cleaned until the bright spots are eliminated. If bright spots are still present then it may be necessary to obtain a replacement showerhead.

The effect of the enlarged holes on the deposition results should be minimal, since they only enlarge the outlet of the hole, hence they do not affect the gas flow.

3.3.6 Optical emission endpoint detector for chamber clean process

Oxford Instruments Plasma Technology has integrated its optical emission spectroscopy (OES) end-point detector with the **Plasmalab** standard PC 2000 operating software. This provides a real-time display of detector signal, and allows for automatic process end-point detection or user terminated end-point.

Part No. 81-12-70

The end-point detector is a fixed, single wavelength detector with a narrow bandpass optical filter and high sensitivity photodiode. The kit includes a KF40 process window and detector mount assembly.

The system monitors the 704 nm wavelength (atomic fluorine) emission. This fluorine is consumed while the deposited material in the chamber is clearing and rises at endpoint, indicating the completion of the chamber plasma cleaning process. An example of clearing a thick film (100um) deposition is shown in the following graph.

**END POINT SIGNAL : SiO₂ CLEANING
(100 microns deposition)**

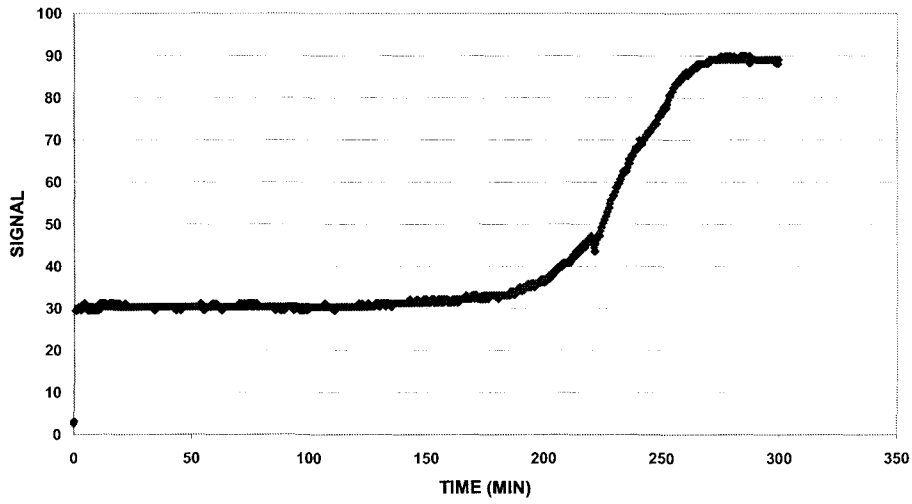

3.4 Process troubleshooting

3.4.1 Partial process failure

3.4.1.1 Example problems

- Etch rate has dropped
- Selectivity reduced
- Profile no longer anisotropic
- Non-uniform etching (or deposition)

3.4.1.2 Typical causes

- Hardware has changed – new gas cylinder, new cover plate, RF connection / grounding is faulty.
- Chamber leak – Check leak-up rate
- Faulty MFC – check partial pressures
- APC cannot control pressure – check MFCs / Pumps
- RF generator/matching – adjust matching unit set-up, check generator range switch, watch HF matching time in mixed frequency pulsed process
- Incorrect gases used
- Temperature – poor clamping / cooling, e.g. particles on electrode/wafer, lift pin not fully down, wafer piece not glued to carrier, incorrect set-up of Eurotherm, high power, or poor resist preparation
- Chamber is dirty – needs more frequent cleaning
- Incorrect process regime (knife-edge process)
- Wrong hardware for given process - wrong cover plate, wafer not being cooled / heated sufficiently, wrong electrode gap
- Wrong process for given hardware - no pumpdown time, no preheat step, no pre-clean step

3.4.2 Total process failure

3.4.2.1 Example problems

- Process not etching / depositing – does plasma ignite?
- Plasma does not ignite/light up
- Plasma is unstable/pulsing
- Plasma is flickering

3.4.2.2 Typical causes

Check that readbacks are within tolerance – MFCs, pressure control, RF matching, temperature.

Check that base pressure has been reached (this can always be changed if you are in a hurry!)

Read error / warning / information messages

Check that plasma is striking – try high pressure strike (>50mT RIE, >8mT ICP), or increased RF power input, or addition of more DC bias

Try selecting 'ignore tolerance' checkbox

Sudden pressure rise – check for dissociation, - try Ar instead, strike at reduced ICP power

Sudden pressure rise at plasma strike – check for cross talk between RF power and CM gauge

Sudden temperature rise at plasma strike – check for cross talk between RF power and temperature gauge

Sudden gas flow change at plasma strike – check for RF cross talk

4 Glossary of terms

AMU	Abbreviation for Automatch Unit. This is a self-controlling variable capacitor, which is connected between an electrode (to which it is normally close-coupled) and the discharge power supply. Its purpose is to shift the voltage and current waveforms to maximise the power transfer. It also transforms the load impedance to 50Ω.
APC	Abbreviation for Automatic Pressure Controller. Refers to a variable conductance valve, which, under the control of a closed loop feedback system, controls the chamber pressure. The controller is a remote electronic module with inputs from a chamber pressure gauge, and from the system master controller.
Backing pump	A pump in series with, and downstream of, the main high vacuum pump. (See also Rotary pump)
Backing valve	The valve which, when open, allows the backing pump to pump gas from the main pump.
Baratron	See CM gauge. <i>Baratron</i> is a trade name.
Base pressure	The lowest pressure attainable by a high vacuum pump. Alternatively, the pressure, which should be attained before starting a process.
Bayard-Alpert gauge	See Ion gauge
Clean gas	This refers, in fact, to 'cleaning gas'. It is a gas which, when converted to a plasma, removes contamination from the walls of the chamber and from the electrodes.
Cluster	An array of processing chambers around a single load lock chamber housing a substrate-handling robot.
CM gauge (Baratron)	Capacitance manometer gauge in which gas pressure deflects a membrane and thus a measured capacitance. Measures absolute pressure down to approximately 10^{-5} Torr. Not affected by corrosive gases. Does not need a correction factor for different types of gas.
Cryo pump (Meissner coil)	These pumps trap gas on a very cold surface. They usually consist of a closed circuit helium refrigeration system. They require periodic regeneration, during which they cannot be used for pumping. Base pressure approximately 10^{-9} Torr.
Driven electrode	The electrode to which the electrical discharge power is applied. The other electrode may be either earthed or at floating potential.
DSμW	An abbreviation for the Downstream Microwave process.
ECR	An abbreviation for the Electron Cyclotron Resonance process.

Electrode	One of two metal plates within the process chamber, which form part of the electrical discharge system. The lower electrode is sometimes referred to as the 'table'. They are fabricated from aluminium alloy or stainless steel, and may either be heated by integral electrical resistance elements, or cooled by chilled water pipes.
Foreline	The line immediately downstream of the high-vacuum pump (see Roughing line).
Foreline pump	See Rotary pump
Gas ballast	Inert gas introduced into a port on a rotary pump to improve its ability to pump condensable vapours.
Gas factor	Ion gauges, Pirani gauges, Penning gauges and mass flow controllers need to be adjusted when run on different gases, to prevent them from being inaccurate. This 'gas factor' depends on the gas and also the type of instrument.
Gate valve	A high vacuum valve with a stainless steel shutter having linear motion. It may be used for high vacuum isolation and also for pressure control.
Hivac valve (High vacuum valve)	The valve which isolates the turbo / cryo pump from the process chamber.
HPN	An abbreviation for 'High Power Neutralizer'; the name the Oxford Instruments Plasma Technology gives to their ion beam neutralizer.
ICP	An abbreviation for Induction Coupled Plasma.
Interlock	A safety device (either software or electrically implemented) that allows a piece of apparatus to function only when predetermined conditions are fulfilled.
Ion beam system	This uses an ion source in a vacuum chamber to direct a flux of energetic ions at a substrate in order to etch the surface or uses the ion source to sputter from a target to deposit material on to the substrate.
Ion gauge (Bayard-Alpert gauge)	This gauge uses a glowing cathode to emit electrons. Any positive ions created by collisions with gas molecules are collected on a thin central ion collection wire. The ion current varies with the gas density. Used for checking very low base pressures down to 10^{-10} Torr. It needs to be calibrated to the gases being measured (see Gas factor). The filament lifetime will be limited in reactive gases.
Leak up rate	The rate of increase of pressure, due to leakage and outgassing, in a sealed chamber, which has been pumped down to base pressure.
Load lock	A sealable chamber adjacent to the processing chamber, which allows the specimen to be loaded onto the substrate table without having to vent the processing chamber.
Meissner coil	See Cryo pump
MFC	Short for mass flow controller. This is a closed loop device, which controls the flow rate of piped gases under the control of an analogue signal. It also outputs a measured flow rate analogue signal. It needs to be calibrated to the gases being controlled (see Gas factor).

Micron	Unit of pressure; 10^{-3} Torr. Equivalent to the pressure required to support a column of mercury one micron (length) high.
Micron	Unit of length; 10^{-6} metres.
Millibar	Unit of pressure; 1/1000 of one atmosphere or bar.
Nupro valve	Nupro is a manufacturer of commonly used pneumatically operated gas line valves.
Outgassing	The vaporisation of contaminants from the surfaces of the components exposed to the vacuum.
PE	An abbreviation for the Plasma Etch process.
PECVD	An abbreviation for the Plasma Enhanced Chemical Vapour Deposition process.
Penning gauge	This gauge uses a glow discharge between electrodes and a permanent magnetic field. The ion current varies with the gas density. Used for checking base pressures down to 10^{-8} Torr. It needs to be calibrated to the gases being measured (see Gas factor).
PFPE	An abbreviation for perfluorised polyether lubricating fluid. This synthetic lubricant is used in a highly oxidising environment where mineral (hydrocarbon) oils would deteriorate too rapidly.
Pirani gauge	Senses the thermal conductivity and hence the pressure of a gas by the power required to maintain the temperature of a warm filament. Used to monitor roughing pump pressures down to approximately 10^{-3} Torr. It needs to be calibrated to the gases being measured (see Gas factor).
Plasma	A region of electrons, positive ions and neutral gas particles created between electrodes within which the various etching or deposition processes take place.
Plasma system	This generates a plasma above a substrate in a vacuum chamber and uses the action of the plasma to etch from, or deposit material onto, a substrate.
Platen	The plate, which supports the substrate to be processed.
RF	An abbreviation for Radio Frequency, often 13.56 MHz.
RIE	An abbreviation for the Reactive Ion Etching process.
Roots pump (blower)	A pump having rotating lobes, which intermesh to give a positive displacement of the pumped gas. The parts of the pump exposed to the pumped gas are usually self-lubricating, i.e. lubricating fluids are unnecessary. Approximate base pressure 1 mTorr.
Rotary pump (backing pump, roughing pump, foreline pump)	Short for Rotary Vane Pump, this consisting of an eccentrically mounted shaft carrying spring-loaded vanes rotating within a cylinder. The vanes are oil sealed. The choice of lubricant depends upon the process. Approximate base pressure 40 mTorr (single stage), 1 mTorr (two stage).
Roughing line	The line between the roughing pump and the chamber.

Roughing pump	A secondary pump, which reduces the chamber pressure from atmospheric to a point at which the high vacuum (or main) pump takes over for a further reduction of pressure. (See also rotary pump)
Roughing valve	The valve which, when open, allows the roughing pump to pump gas from the chamber.
Sample	See Substrate
Shower head	A form of top electrode having perforations through which the process gas is introduced into the chamber.
Silane	A process gas, SiH ₄ , which is commonly used in deposition processes. It is extremely toxic, pyrophoric, and, under certain conditions, explosive.
Slit valve	A two-position gate valve used to seal the apertures between chambers.
SMC valve	SMC is the manufacturer of commonly used solenoid operated pneumatic valves. The valves are normally closed, and on receipt of an electrical signal, the pneumatic valve opens. In some cases, the opposite action is used, for example to vent a turbo pump if system power is lost.
Specimen	See substrate.
Substrate / wafer / specimen / sample	The item to be processed in the vacuum chamber.
TEOS	Abbreviation for Tetra Ethoxy Silane. TEOS is a liquid at normal temperature and pressure. In gaseous form it is used in PECVD processes. It is a replacement for silane in silicon oxide deposition.
Throttling valve	An adjustable valve.
Torr	Unit of pressure; 1/760 of one atmosphere or bar.
Turbo pump	Short for turbomolecular pump, this being a multistage axial flow fan rotating at very high speed. Base pressure approximately 10 ⁻⁹ Torr.
Wafer	See Substrate.
Vent	Introduce high purity nitrogen into a chamber or pump to raise it to atmospheric pressure.

NOTES:

5 OIPT locations worldwide

UK

Oxford Instruments Plasma Technology
North End, Yatton,
Bristol, BS49 4AP
Tel: +44(0)1934 837000
Fax: +44(0)1934 837001
Email: plasma.technology@oxinst.co.uk
Web: www.oxford-instruments.com/plmchp5.htm

USA

Oxford Instruments Inc.
130A Baker Avenue Extension
Concord, MA 01742
Tel: +1 978 369 9933
Toll Free +1 800-447-4717
Fax: +1 978 369 8287
Email: info@ma.oxinst.com

Germany

Oxford Instruments GmbH
Otto-von-Guericke Ring 10,
D-65205 Wiesbaden
Tel: +49(0)6122 937161
Fax: +49(0)6122 937175
Email: plasma@oxford.de

Japan

Oxford Instruments K.K.
2-11-6 Tomioka
Koto-ku, Tokyo 135-0047
Tel: +81-3-5245-3261
Fax: +81-3-5245-4466
Email: oiokpt@oxinst.co.jp
Web: www.oxford-instruments.jp

People's Republic of China (Beijing)

Oxford Instruments China
Room 714, Office Tower 3,
Henderson Center,
No. 18 Jianguomennei Ave,
Dongcheng District,
Beijing 100005
Tel: +86 106518 8160/1/2
Fax: +86 106518 8155
Email: ptsales@oichina.cn
Web: www.oxford-instruments.com.cn

People's Republic of China (Shanghai)

Oxford Instruments China
Room 14-F, No.1 Plaza
800 Nanjing East Road
Shanghai 200001
Tel: +86 216360 8530
Fax: +86 216360 8535
Email: ptsales@oichina.cn
Web: www.oxford-instruments.com.cn

Singapore

Oxford Instruments Pte. Ltd
371 Beach Road,
#02-07 Keypoint
Singapore 199597
Tel: +65 6337 6848
Fax: +65 6337 6286
Email: oipt.sales@oxford-instruments.com.sg

Taiwan

Oxford Instruments Overseas
Marketing Ltd.
1F, No 23 Jing-Shang 19th Street,
Hsinchu, Taiwan
Tel: +65 6337 6848
Fax: +65 6337 6286
Email: oipt.sales@oxford-instruments.com.sg

WARNING**BEFORE PROCEEDING WITH ANY MAINTENANCE WORK, READ SECTION 1 - HEALTH AND SAFETY.**

8. Uninstallation and Disposal

8. Uninstallation and Disposal	8-1
8.1 About this section	8-2
8.2 Uninstalling the system.....	8-2
8.2.1 General considerations for shutting the system down.....	8-2
8.2.2 Shutting the system down	8-2
8.2.3 Disconnecting the services	8-3
8.2.4 Decontamination	8-4
8.2.5 Dismantling the system components	8-4
8.3 Disposal	8-5

WARNING**BEFORE PROCEEDING WITH ANY MAINTENANCE WORK, READ SECTION 1 - HEALTH AND SAFETY.**

8.1 About this section

This section gives guidance for the uninstallation of a **Plasmalab** or **Ionfab** system prior to moving it to another location or disposing of it. Guidance is also given for the disposal of a system.

The guidance given is by necessity of a general nature; detail will vary depending on system type, customer's site, etc.

IMPORTANT: BEFORE UNINSTALLING THE SYSTEM, ENSURE THAT ALL PERSONNEL WHO WILL BE INVOLVED HAVE READ AND UNDERSTOOD SECTION 1 'HEALTH AND SAFETY' OF THE SYSTEM MANUAL.

8.2 Uninstalling the system

To uninstall the system, carry out the following sub-sections in sequence.

8.2.1 General considerations for shutting the system down

The main use of this document will be when a customer requires to move a system to another location. This will involve uninstalling the system, moving the system components and then reinstalling the system. An important consideration is the length of time between shutting the system down and powering the system up. The longer the system is shut down, the greater the need to remove as much residue gas as possible.

It is very important that the customer follows the pump manufacturer's instructions for purging pumps prior to shut down. For periods of more than a few days shutdown, 24 hours of N₂ purging is often recommended.

If the system is to be reinstalled, the vacuum system should be left fully vented with dry nitrogen, with the pump and gas supply service points capped.

8.2.2 Shutting the system down

- 1) Chamber¹ or ion source² plasma cleaning should be conducted to remove residues. Use the normal cleaning process according to the most recent use of the tool.
- 2) Process gas supply lines must be pumped down using the system at least as far as the last isolation valve upstream from the gas pod. Consider whether the gases should be pumped out back to the cylinder, or whether the gas installation has alternative means of exhausting hazardous gases. For shut down periods of longer than two days, purge the gas lines with N₂.
- 3) *Pump the system according to the following criteria:*

Systems fitted with turbomolecular pumps:

- a) For a shut down period of less than two days, pump the system for three hours.
- b) For a shutdown period of longer than two days: Pump the system for one hour with a small N₂ flow, followed by a 12-hour pump down with no gas flow.

¹ For Plasmalab systems, refer to Section 6 (Maintenance) of the System Manual.

² Run a 'discharge' for > 1 hour at ~500W (15cm or 35cm ion source), ~150W (3cm ion source).

WARNING**BEFORE PROCEEDING WITH ANY MAINTENANCE WORK, READ SECTION 1 - HEALTH AND SAFETY.****Systems without turbomolecular pumps:**

- 4) Pump the system for one hour with a small N₂ flow, then pump for a further hour with no gas flow.
- 5) The process chamber, load lock and transfer chamber (if applicable) should be vented with dry nitrogen and the process gas inlet blanked.
- 6) Ensure that the system has been shut down in accordance with the procedure given in Section 5 (Operating Instructions) and Appendix B (Operation and Maintenance of Turbomolecular Pumps).
- 7) Depending on system type, ensure that the front panel compressed air lockout valves are set to their OFF positions and padlocked. (e.g. slit valves, gate valves, RGA, etc. if fitted)

8.2.3 Disconnecting the services

IMPORTANT: BEFORE DISCONNECTING ANY OF THE SERVICES, ENSURE THAT THEY ARE TURNED OFF. E.G. COMPRESSED AIR AND GAS SUPPLY VALVES SET TO THEIR OFF POSITIONS AND ELECTRICAL SUPPLIES SWITCHED OFF AND LOCKED OUT.

- 1) Ensure that all covers and panels are fitted and attach notices to the system indicating that the system is not ready for service.
- 2) Disconnect the electrical supply from the PC.
- 3) Disconnect the electrical supply from the safety isolation box to the system console.
- 4) At the system PC, disconnect the monitor, keyboard and mouse, then disconnect the control cable(s) from the PC to the system console.
- 5) Disconnect the safety earth (ground) between the system and the gas pod, if the gas pod is not bonded to the system.
- 6) Disconnect the cooling circuits from the system console. Coolant may be removed, if so wished by using low pressure (< 1 bar gauge) compressed air. Do not seal the cooling circuits tightly.
- 7) Disconnect the gas outlet line(s) and control cable from the gas pod to the system services panel.
- 8) Disconnect the gas supplies to the gas pod (all gas supply valves closed).
- 9) Disconnect the compressed air supply from the system services panel(s) and from the gas pod.
- 10) Disconnect the Nitrogen purge lines to the system services panel(s) and the rotary vane pump(s).
- 11) Disconnect the rotary pump(s) from the system and cap the pump ports and the system vacuum ports.
- 12) Disconnect the rotary vane pump exhaust line.

WARNING**BEFORE PROCEEDING WITH ANY MAINTENANCE WORK, READ SECTION 1 - HEALTH AND SAFETY.**

- 13) Disconnect the extraction collars on the process chamber(s) (e.g. ICP process chambers) and the gas pod from the extraction systems.

8.2.4 Decontamination

Remove any hazardous residues/deposits from the process chamber, ion sources, pumps and pump lines, gas lines and mass flow controllers in accordance with local safety regulations. Refer to equipment manufacturer's manuals as necessary.

Note that if the system is to be moved and re-installed, it may be acceptable to purge the gas lines / mass flow controllers and ion sources (if fitted) with dry nitrogen and seal all connections.

8.2.5 Dismantling the system components

**WARNING****LIFTING HEAVY OBJECTS INCORRECTLY CAN CAUSE SEVERE INJURY**

When handling heavy system components such as the system unit or vacuum pumps, ensure that the appropriate lifting equipment, operated by fully trained personnel, is used.

When heavy rack-mounted components are handled, ensure that the weight is safely distributed between sufficient personnel.

**WARNING****TOPPLING (TIPOVER) HAZARD – SOME SYSTEM COMPONENTS, E.G. ROBOTIC HANDLERS AND AUTOMATIC LOAD LOCKS / TRANSFER CHAMBERS (ESPECIALLY IF FITTED WITH CASSETTE LOAD LOCKS) CAN TOPPLE CAUSING SEVERE INJURY.**

When transporting or manoeuvring the system frames, robotic handlers etc., ensure that they remain vertical at all times and use the appropriate lifting / handling equipment.

Ensure that any support frames, supplied with the system, are correctly fitted whenever the system is transported / manoeuvred or dismantled for service / maintenance.

It is entirely the user's responsibility to ensure that all components are supported safely before and during any transporting, manoeuvring or maintenance operations. Support frames provided by Oxford Instruments Plasma Technology are not necessarily adequate for any such operations. The absence of a support frame must not be taken as an indication that no further precautions need to be made before such operations are undertaken.

- 1) In the grey area, remove the rotary vane pump from its mounting and prepare it for transport in accordance with the pump manufacturer's instructions. Refer to the manufacturer's literature in Volume 3 of this manual.
- 2) Remove the gas pod from its mounting and prepare it for transport.
- 3) Prepare the system PC for transport.

WARNING**BEFORE PROCEEDING WITH ANY MAINTENANCE WORK, READ SECTION 1 - HEALTH AND SAFETY.**

- 4) Prepare the system frames for transport by disconnecting processing modules from the transfer chamber (if applicable) and fitting the castor assemblies.

8.3 Disposal

This sub-section gives guidance for disposing of the system at the end of its life. The disposal must be carried out in accordance with local safety regulations.

To dispose the system, use the following procedure:

- 1) Carry out the uninstallation procedure given in sub-section 8.2, page 8-2
- 2) Locate, remove and dispose of any hazardous materials in accordance with local safety regulations, e.g. batteries, o-rings, oil etc. Refer to manufacturer's manuals.
- 3) Dispose of the remainder of the system in accordance with local safety regulations.

WARNING

BEFORE PROCEEDING WITH ANY MAINTENANCE WORK, READ SECTION 1 - HEALTH AND SAFETY.

NOTES:

Appendix A Measurement of radio frequency and microwave emissions

1.	Scope of testing	2
2.	Method of testing	2
3.	Acceptable exposure standards.....	3
4.	System design	3

WARNING

THIS APPENDIX COVERS ALL OF THE CURRENT REQUIREMENTS FOR THE MEASUREMENT OF RADIO FREQUENCY AND MICROWAVE EMISSIONS FOR THE OXFORD INSTRUMENTS PLASMA TECHNOLOGY'S RANGE OF PRODUCTS. ENSURE THAT THE ENTIRE APPENDIX IS READ AND UNDERSTOOD BY ALL INVOLVED PERSONNEL AND THAT THE TESTS RELEVANT TO THE INSTALLED SYSTEM ARE CARRIED OUT AT THE SPECIFIED PERIODICITY.

1. Scope of testing

Systems which contain RF generators, both Ion Beam and Plasma systems will be tested for the emission of energy prior to shipment. They will also be tested routinely every three months during use, or as required by safety standards at the customer's site, if this is more frequent.

Systems must also be tested after maintenance, if the maintenance has involved RF shielding components such as covers and viewports, or components in the process chamber such as feedthroughs and vacuum gauges.

Systems with RF generators in the frequency range of 0.1 MHz to 27.12 MHz must be tested for emissions by measuring separately both the electric (E) and magnetic (H) field strengths. Either field can be a safety hazard, hence the need to test both.

Systems with microwave frequency generators at 2.45 GHz will only be tested for power, usually by measuring the electric (E) field.

2. Method of testing

Suitable test meters are the Narda¹ 8511 for 1.7MHz to 2.1MHz, the Narda 8512 for 13.56 MHz and 27.12 MHz, and the Holaday² 1501 for 2.45 GHz. Equivalent meters from other vendors are acceptable. The test meter MUST have a current calibration certificate. Note that if an alternative 13.56 MHz meter is used, it should be able to detect the presence of 27.12 MHz as well as 13.56 MHz.

Testing must be performed on the system in its normal operating configuration, with the usual covers and components in place. The system must be operating at maximum reasonable power, and must be tested both in the presence and the absence of plasma.

The field strength must be measured 50 mm (2 inches) away from the system, at all points that can be reached by hand with the probe (If parts of the system are inaccessible from the ground, a stepladder must be used). The probes of the above meters are designed so that the correct distance is obtained if the head of the probe is touching the system.

Particular attention must be given to viewports, doors and flanges, the automatch unit, and the whole length of waveguides and RF power cables. If viewports are fitted with shutters, then tests must be made with the shutter both open and shut. All cables leaving gauges and other feedthroughs in the process chamber and the pumping system are suspect, and must be checked along their entire length. The pumping system and any separate system racks and power box must also be checked.

¹The Narda Microwave Corporation, Plainview, New York 11803.

²Holaday Industries Inc, 14825 Martin Drive, Eden Prairie, MN 55344.

It is strongly recommended that the operation of all safety interlocks should be tested at the same time, whenever an RF or Microwave leakage test is performed.

3. Acceptable exposure standards

Readings must be equal to or less than the levels shown in Table 1 at all points. Exceptions will only be permitted in certain special circumstances. These exceptions will be clearly documented in the system instructions. In all other situations, these standards must be strictly met.

Frequency	Electric Field (E)		Magnetic field (H)	
	V/m	mW/cm ²	A/m	mW/cm ²
0.1 to 1 MHz	614		16.3/f	
1.7 to 2.1 MHz	614		16.3/f	
13.56 MHz and 27.12 MHz	1842/f	900/f ²	16.3/f	10000/f ²
2.45 GHz		f/300		f/300
Note - f is the frequency in MHz				
Reference: ANSI/IEEE C95.1 maximum permissible exposure for controlled environments.				

Table 1 - Maximum permitted field strengths

4. System design

RF and Microwave components such as RF ion sources may be purchased from Oxford Instruments Plasma Technology and fitted to the customer's system. Such an installation requires a system designed to prevent leakage of RF and Microwave emissions, and requires careful testing by the installer before use.

It is not possible to give a full list of necessary safety precautions, and advice should be sought from a competent authority. However, some of the points to be considered are as follows:

- (a) The system and all of its assemblies should be very well grounded (earthed), using low impedance straps, and ensuring impedances between power supplies and the chamber of ≤ 0.1 Ohms at 25 A.
- (b) Viewports should be shielded with fine conducting mesh to prevent the transmission of RF and Microwave energy, and should be filtered to prevent the transmission of UV light.
- (c) Doors and flanges should provide metal-to-metal contact. In case of doubt, and in the case of access doors, the use of copper beryllium finger strips or wire mesh over elastomer core (e.g. Zemrex products from Warth International³ should be considered. Small flanges in the vacuum system should be joined with metal clamps, not plastic.
- (d) All types of electrical feedthrough and vacuum gauges, together with cables leaving them, may need shielding.
- (e) Interlocks will need to be wired into the system to ensure safe operation. These will include interlocks with the system access door, the customer's water supply to the RF product, and the system vacuum. The product purchased from Oxford Instruments Plasma Technology will also have interlock switches. These interlocks must all force the disconnection of power from the RF, Microwave and HV power supplies if they are opened. See the product manual for more details.

³Warth International Ltd, Charlswood Road, East Grinstead, Sussex, England, RH19 2HH.

NOTES:

Appendix B Operation and maintenance of turbomolecular pumps

Appendix B	Operation and maintenance of turbomolecular pumps	1
1	Maintenance for all Turbo Pumps.....	2
2	Maintenance for Alcatel ATP/ACT Turbo pumps	3
2.1	Re-greasing of turbo pumps fitted to process chambers.....	3
2.2	2000 to 8000 hours (3 to 12 months): pump relubrication.....	3

1 Maintenance for all Turbo Pumps

Please note that premature failure of Turbomolecular Pumps can be caused by failing to observe the following recommendations:

- a) Always follow the maintenance and operating instructions contained in the manufacturers' manuals, copies of which are provided within the system manuals. Note that with some types of pump the lubricant should be replaced when the total running time reaches 500 hours.
- b) When corrosive process gases are being used always purge the turbo pump with dry nitrogen during a processing run. If the process chamber is to be vented adequate time must first be allowed for the process gases to be pumped away.
- c) If corrosive process gases are used in a system with **no gate valve** between the turbo pump and the process chamber and the system is to be left for more than one hour with the turbo pump not running, proceed as follows:
 - 1) Turn off all the manual gas taps on the process gas lines. Also turn off the gas taps on the process gas cylinders.
 - 2) Close the chamber door.
 - 3) Pump the process chamber and turbo pump down to approximately 1×10^{-4} millibars.
 - 4) Vent the process chamber and turbo pump to atmospheric pressure with dry nitrogen. Do not allow the chamber door to open.
 - 5) Repeat Steps 3 and 4 three times.
 - 6) Seal the process chamber and turbo pump.
- d) If corrosive process gases are used in a system **with a gate valve** between the turbo pump and the process chamber and the system is to be left for more than one hour with the turbo pump not running, proceed as follows:
 - 1) With the exception of the Argon and Nitrogen lines, turn off all the manual gas taps on the process gas lines and also turn off the gas taps on the process gas cylinders.
 - 2) Close the chamber door.
 - 3) Run a 'process' sequence (without any samples loaded) using only Argon or Nitrogen as process gases for at least 10 minutes.
 - 4) Vent the process chamber and vent the turbo pump to atmospheric pressure with dry nitrogen. Do not allow the chamber door to open.
 - 5) Pump the process chamber and the turbo pump down to 1×10^{-4} millibars and then vent them with dry nitrogen.
 - 6) Repeat Step 5 three times.
 - 7) Seal the process chamber and the turbo pump.

2 Maintenance for Alcatel ATP/ACT Turbo pumps

2.1 Re-greasing of turbo pumps fitted to process chambers

The following instruction applies to conventionally greased bearing turbo pumps, e.g. the Alcatel ATP series. It does not apply to Maglev turbo pumps.

To prevent damage to turbo pumps fitted to process chambers, OIPT strongly recommends that bearing re-greasing is carried out periodically after every 2500 hours of pump running time.

Details of re-greasing are given in the following sub-section.

2.2 2000 to 8000 hours (3 to 12 months): pump relubrication

CAUTION

Failure to perform regular pump maintenance will result in pump warranty being suspended.

Refer to the manufacturer's manual in Volume 3 of this manual.

Alcatel ATP series turbo pumps are conventional greased bearing pumps. Periodically, these bearings need to be re-greased.

The re-greasing interval depends on a number of factors; Refer to the graph in the Maintenance section of the manufacturer's manual to establish the re-greasing interval for the pump in your system.

Remember that turbo pumps fitted to process chambers must be re-greased at 2500 hour intervals. The re-greasing interval for turbo pumps fitted to load locks and transfer chambers is not so critical, therefore the manufacturer's recommendations can be used.

The ATP turbo pumps are supplied with series ACT intelligent controllers which are menu-driven. The 'SET-UP' menu allows the re-greasing interval to be set so that a visual warning with an optional audible alarm is displayed at the relevant time. Note that this visual warning does not require any action immediately; it only indicates that the bearing should be re-greased at the next available opportunity. If required, the visual warning and audible alarm can be disabled via the 'SET-UP' menu.

When the pumps are supplied, the ACT controller is pre-set with a 5,000 hour re-grease interval. If the pumps are running continuously, the visual re-grease warning will be automatically triggered after approximately seven months.

The customer is advised to use the 'SET-UP' menu to set the re-greasing interval for the pump fitted to his system. Refer to the pump manufacturer's manual. Note that this change takes approximately five minutes.

When the re-greasing time is reached, lubrication is carried out using a pre-loaded syringe to apply a metered quantity of a specific grease to one point on the bearing. Refer to the pump manufacturer's manual. The Alcatel part numbers of the syringes are:

Pump Type	Pre-loaded Syringe Part Number
ATP80	056993
150C/400HPC/900HPC	101924

Note that the grease syringe has a limited shelf life so shouldn't be ordered from the Alcatel service centre until it is needed. Alcatel exercises strict stock control on this item to ensure that the grease is always in good condition.

Once the grease has been applied to the bearing, it needs to be evenly distributed around the bearing. This is done automatically by using the ACT controller's 'RUNNING IN' menu. **Note that the grease distribution takes approximately 2.5 hours.**

Appendix C Concessions

Appendix C Concessions	1
1.1 General	2

1.1 General

A Concession is a Quality Assurance form (QCF27 Engineering Concession) that gives details of a modification applicable to this **Plasmalab** or **Ionfab** system. Each concession is referenced with a unique serial number.

This Section contains a copy of the concessions (if any) applicable to this system, for the Customer's reference.

If there are any applicable concessions, they will be located immediately after this Section (Appendix C), or published as a standalone .pdf file in the same folder as this manual.

Appendix E PC hard drive restore information

Appendix E PC hard drive restore information 1

1. About this Appendix 2

2. Introduction 2

3. Hard disk restore procedure 3

CAUTION

The Norton Ghost 2003® 'Restore' DVD supplied with your OIPT system will only restore the PC's hard disk providing the Specification of the PC is as defined by OIPT.

1. About this Appendix

This Appendix gives information about restoring the hard drive on your OIPT PC after a hard drive failure.

2. Introduction

Every OIPT system is supplied with a system PC to enable the customer to run the necessary software to control the system. On very rare occasions, the PC can fail rendering the system unusable. Repairing the PC and, if necessary, replacing the OIPT software can take some time.

To help remedy this situation, OIPT supplies each system PC with a hard disk 'Restore' package to allow the PC's hard drive to be restored to the state it was in when it was shipped from OIPT. The package comprises the following items:

- (A) A DVD containing a compressed mirror image¹ of the hard drive as it was when shipped from OIPT.
- (B) A bootable floppy disk containing the software utility necessary to copy the mirror image from the DVD to the system PC's hard drive. (²Norton Ghost 2003[®].)
- (C) A booklet giving detailed instructions for restoring the hard drive.

Note that items (B) and (C) are contained in the DVD case.

The DVD and floppy labels contain the OIPT PC serial number which is also labeled on the rear of the PC (next to the OIPT logo). This OIPT serial number is unique to your system PC. Only use the 'Restore' package containing this OIPT PC serial number on the system PC which is also labeled with this number.

The 'Restore' package will help you to quickly get your system up and running again. Ensure that you keep it in a safe place where it is readily available.

The method of restoring the hard drive comprises three main stages:

- (1) Obtain and fit the new hard drive into the PC.
- (2) Copy the mirror image from the DVD to the hard drive.
- (3) Re-boot the PC.

A detailed procedure for carrying out the restore is given in Section 3.

¹ A mirror image is an exact copy of the hard drive including all operating system, application and user files.

² All screen representations contained in this document are derived from Norton Ghost 2003. Each full screen contains the Copyright warning 'Norton Ghost 2003 Copyright (C) 1998-2002 Symantec Corp. All rights reserved.'

3. Hard disk restore procedure

CAUTION

DO NOT ATTEMPT THE FOLLOWING PROCEDURE IN ANY CIRCUMSTANCES OTHER THAN TO RESTORE YOUR HARD DISK DRIVE ON YOUR OIPT SYSTEM PC. ENSURE THAT THE OIPT PC SERIAL NUMBER ON THE PC MATCHES THE PC SERIAL NUMBER ON YOUR 'RESTORE' DVD AND THE 'RESTORE' FLOPPY DISK.

NOTE: The following procedure can be carried out without the system PC connected to the OIPT system.

- (1) Obtain a replacement hard drive. (EIDE with a capacity equal to or greater than that of the original hard drive.)
- (2) Physically install the hard drive into the PC. (Follow the hard drive manufacturer's instructions.)
- (3) Place the 'Restore' floppy disk into Drive A.
- (4) Power up the PC and immediately open the DVD drive, place the 'Restore' DVD onto the DVD drive's tray and then close the DVD drive. The hard drive should be automatically detected and the PC should boot from the floppy disk.
- (5) At this point, you may see the Norton Ghost 2003® License agreement warning screen displayed. If so click the **Continue Without Marking Drive** button, otherwise, proceed to Step 6).

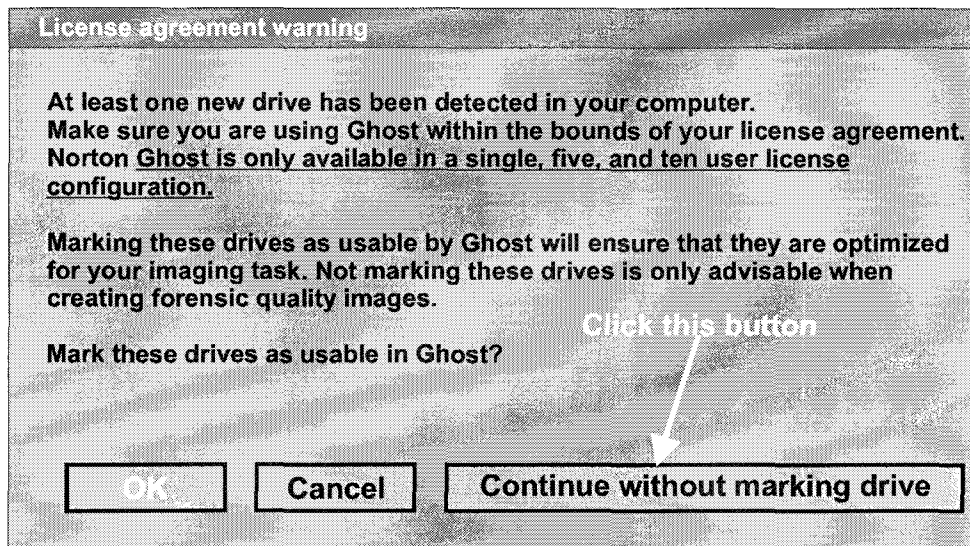

- (6) The 'About Norton Ghost' screen is displayed; click on the **OK** button.

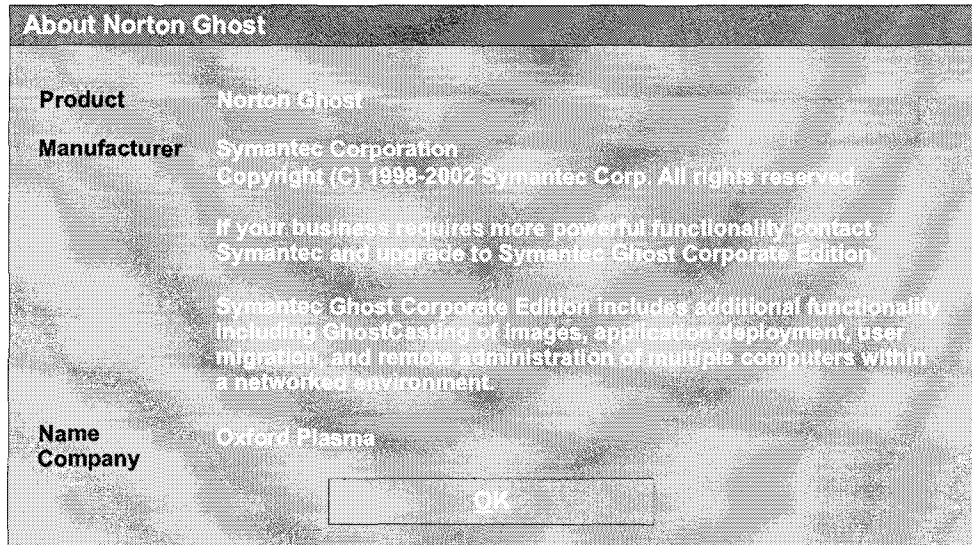

- (7) The selection Menu is displayed. Move the mouse pointer over the '**Local**' menu and then over on the '**Disk**' option and then click on the '**From Image**' option.

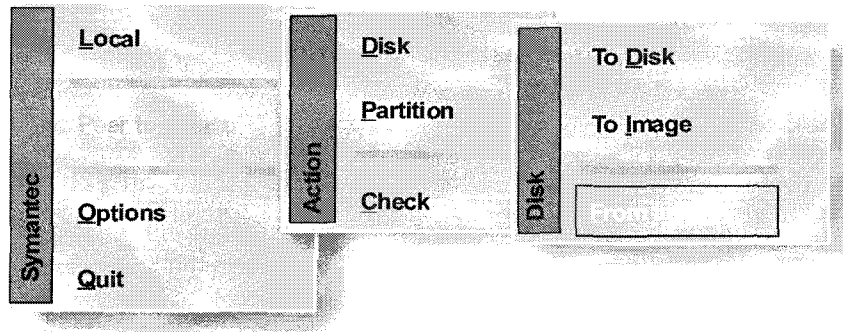

- (8) The 'Image file name to restore from' screen is displayed. Click on the '**Look In**' drop-down menu and then select the CD Rom drive named '**Backup**'.

Note that the following screens will differ in detail, depending on your PC's configuration.

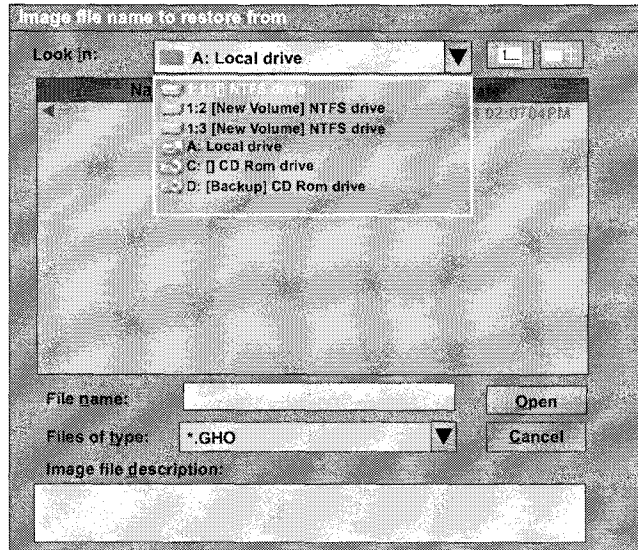

- (9) The screen changes to display the backup CD Rom drive selected with the '**BACKUP**' folder listed. Click on the '**BACKUP**' folder and select the file named '**Backup.gho**'.

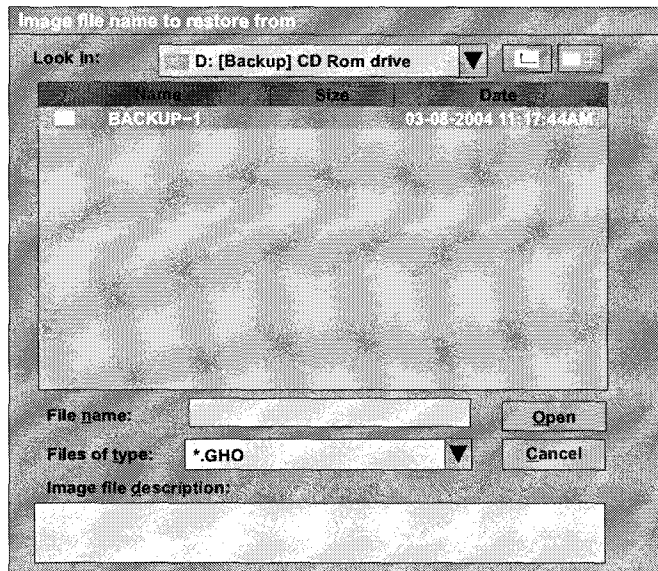

- (10) The next screen displays the destination drive already selected; click on the **OK** button.

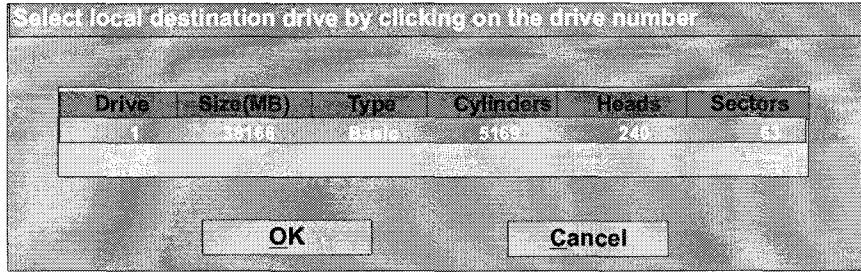

- (11) The 'Destination Drive Details' dialogue is displayed, click on the **OK** button.

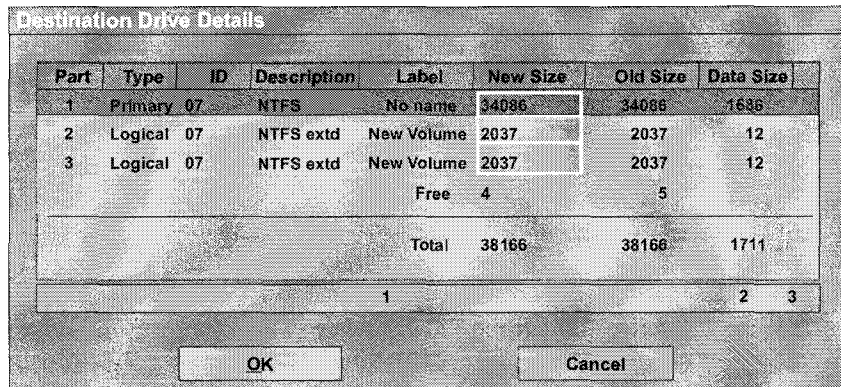

- (12) The following message is displayed:

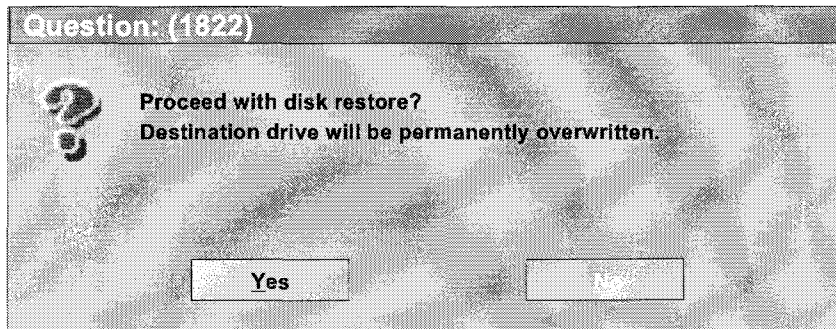

- (13) Click on the **YES** button to start the restore operation.
- (14) Details of the restore progress are displayed. The restore operation will take approximately five minutes (depending on the speed of the hard disk).

- (15) When the restore operation is complete, the following message is displayed:

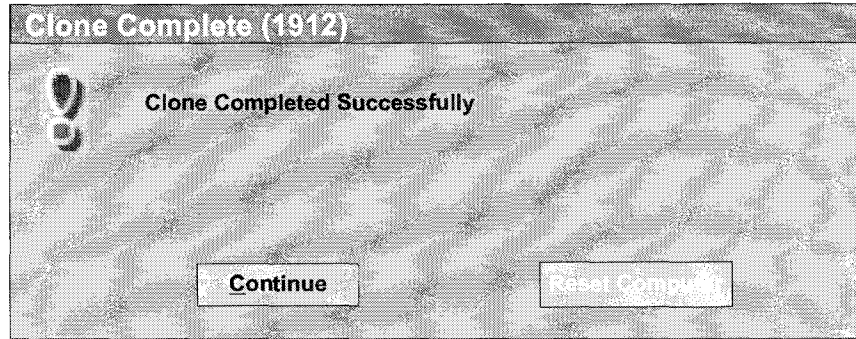

- (16) Remove the floppy disk and DVD from their respective drives.
- (17) Click on the **Reset Computer** button.
- (18) The PC will now boot from the system hard drive. Note that the system may run 'Scandisk' at this time, if so do not interfere. Microsoft Windows™ will automatically start up.
- The PC has now been restored to the state it was in when it was shipped from OIPT. If you have received any software updates from OIPT since the system was shipped, you can install them now.
- (19) If necessary, switch off the system PC and connect it to the OIPT system. The PC can now be switched on to control the OIPT system.

NOTES:

Plasmalab

Modular Cluster System - ICP 180

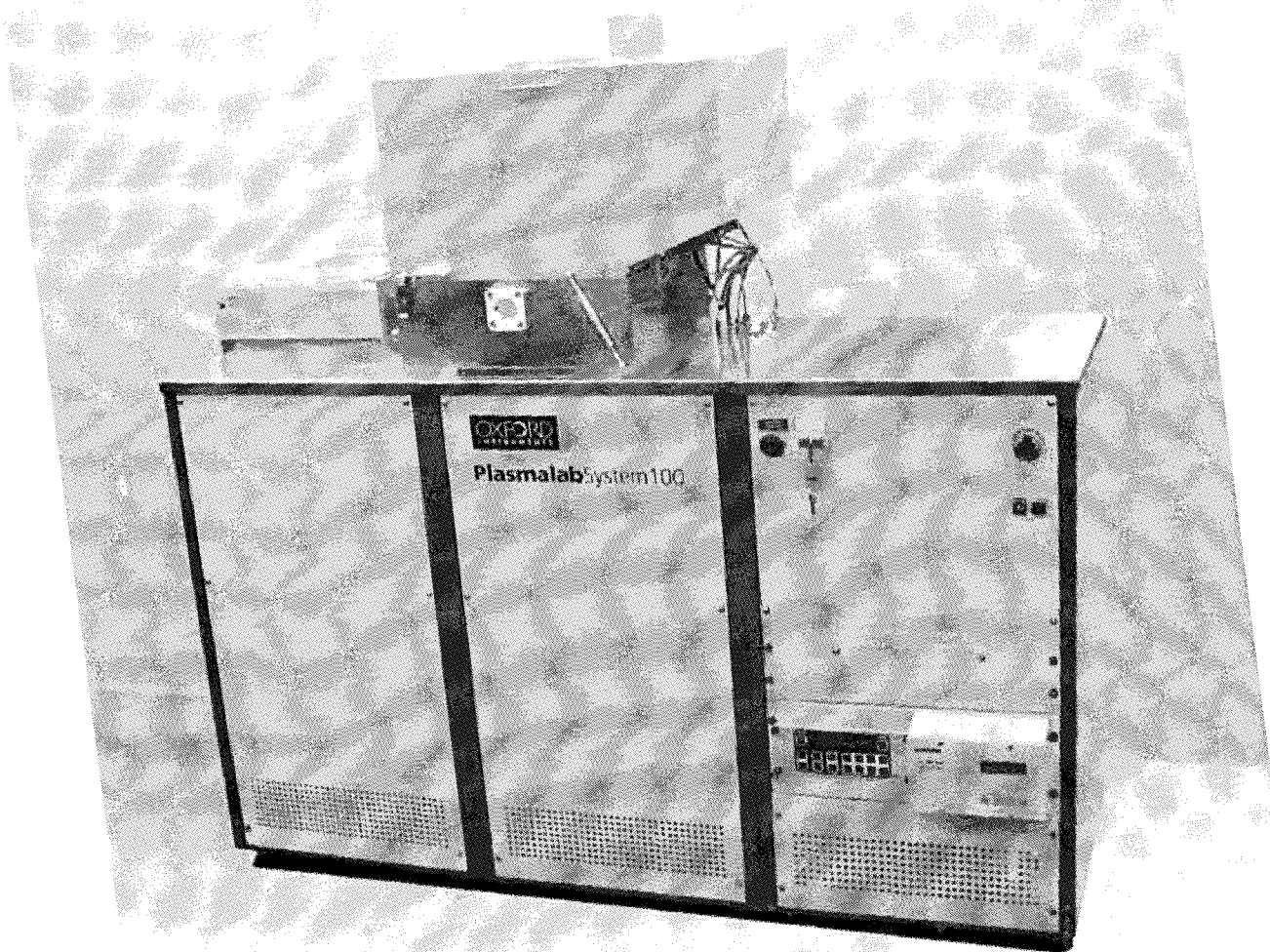

Contents

	Page
Change record sheet.....	2
1. Introduction	4
2. Installation information.....	5
2.1 Dimensions.....	5
2.2 Weights	5
2.3 Heat load	5
3. Services connections	9
4. Gas handling	11
5. Services.....	14
5.1 Electrical Supply requirement	14
5.2 Water Cooling requirement	14
5.3 Lower Electrode Cooling requirement	14
5.4 Compressed Air requirement	14
5.5 Nitrogen requirement.....	15
5.6 Process gas requirement	15
5.7 Helium requirement.....	15
5.8 Extraction requirement.....	15
6. Pump set information	16
6.1 Rotary pump purging.....	16
7. Heater/chiller information	16
8. Interlocks.....	17
9. OIPT locations worldwide	18
Fig 1: ICP 180 system layout (3-frame)	6
Fig 2: ICP 180 system layout (3-frame cluster upgradeable).....	7
Fig 3: ICP 180 Layout (2-frame cluster upgradeable)	8
Fig 4: ICP 180 services panel.....	9
Fig 5: Electrical connections	10
Fig 6: 6-line gas pod	11
Fig 7: 6-line gas pod mounted on optional free-standing frame	12
Fig 8: 12-line gas pod	13

1. Introduction

This installation specification document gives information about the **PlasmalabSystem100** to enable customers to prepare the required environment for the system.

Note that all dimensions shown in these data sheets are typical; precise dimensions depend on the actual equipment fit. All dimensions are given in millimetres unless otherwise stated.

NOTE: All information, services, dimensions etc., refer only to the **PlasmalabSystem100**, i.e. plasma processing at up to 200 mm wafers in MESC compatible chambers.

Oxford Instruments Plasma Technology conducts a programme of continual product development, and reserves the right to change the design and/or specification of equipment without notice. The details contained in this document were correct at the time of printing but should be confirmed immediately prior to delivery. Details of the clean room interface will be advised at the time of delivery.

2. Installation information

2.1 Dimensions

System dimensions are given in Fig 1, Fig 2 and Fig 3. Gas handling component dimensions are given in Fig 6, Fig 7 and Fig 8. Pump dimensions are given in Section 6. Heater/chiller dimensions are given in Section 7.

2.2 Weights

Typical weights of system components:

2-frame system: 320 kg

3-frame system: 390 kg

6-line Gas pod: 35 kg

12-line Gas pod: 65 kg

Pumps: See Section 6 (Pump set information).

Heater/chillers: See Section 7 (Heater/chiller information).

2.3 Heat load

The typical heat load for the clean room installation is:

Operating: 2 kW

Passive: 1.5 kW

Note that these specifications do not include externally sited components, e.g. pumps, heater/chillers, transformers, etc..

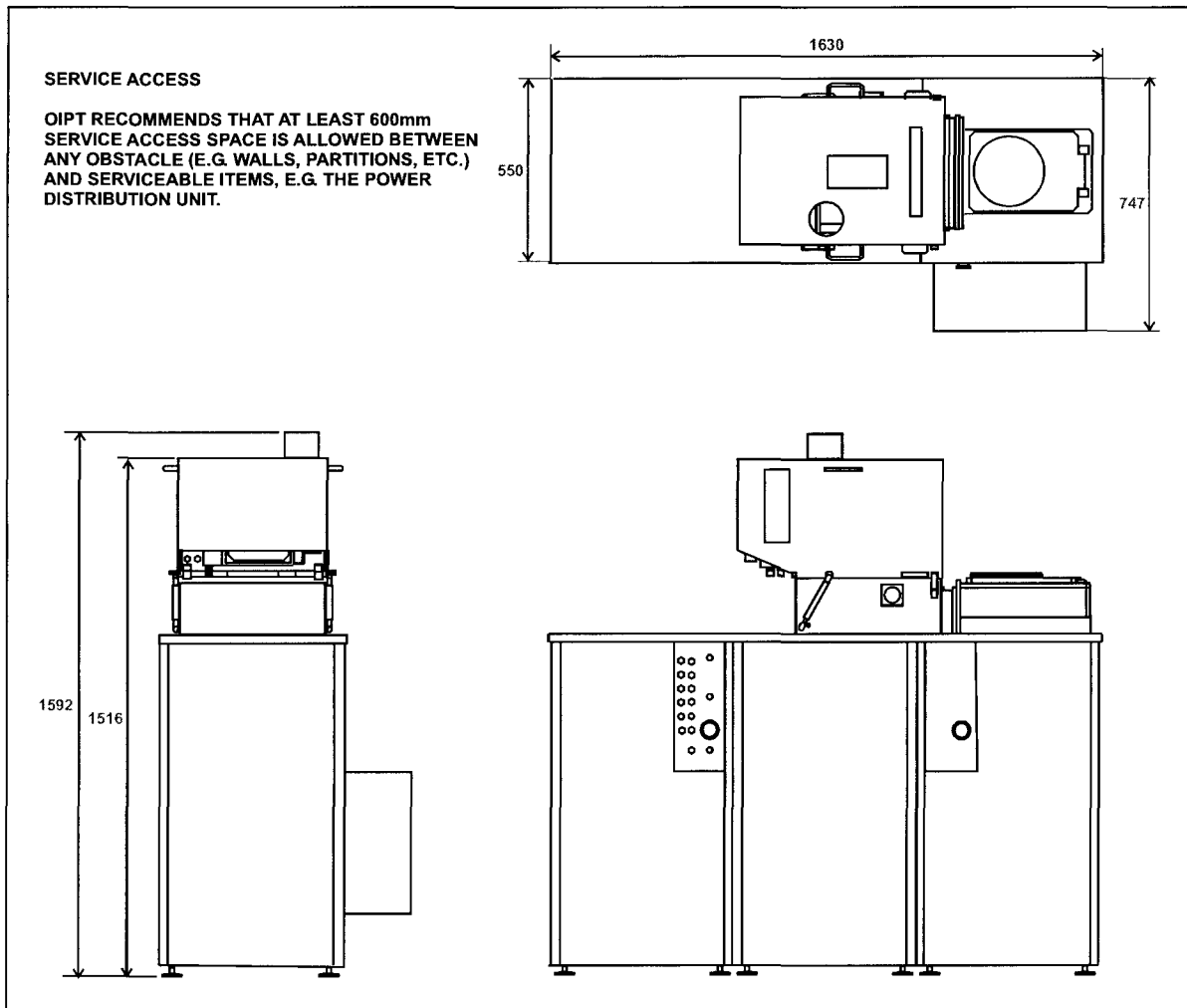

Fig 1: ICP 180 system layout (3-frame)

NOTE: For services panel details, see [Fig 4](#).

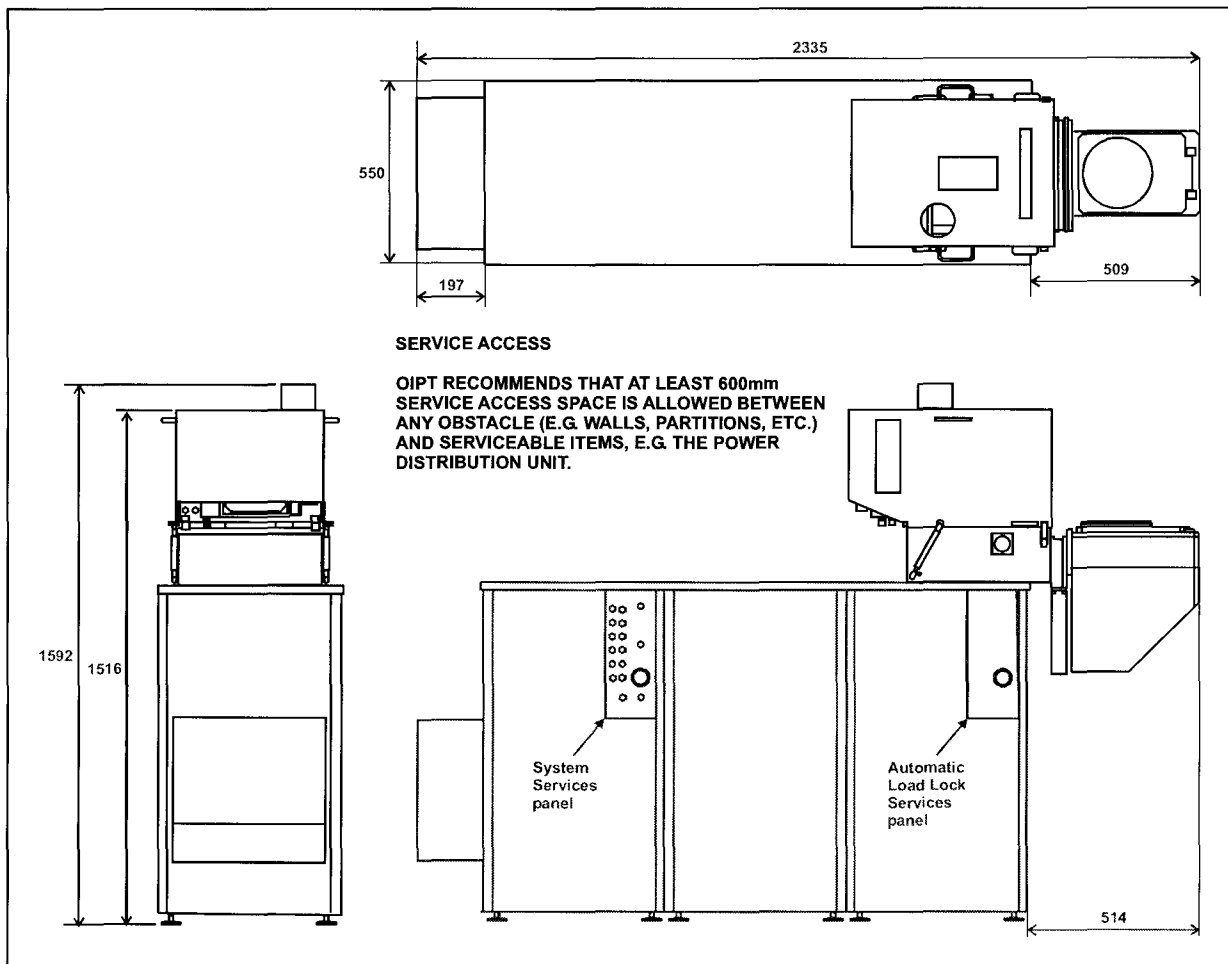

Fig 2: ICP 180 system layout (3-frame cluster upgradeable)

NOTE: For services panel details, see Fig 4.

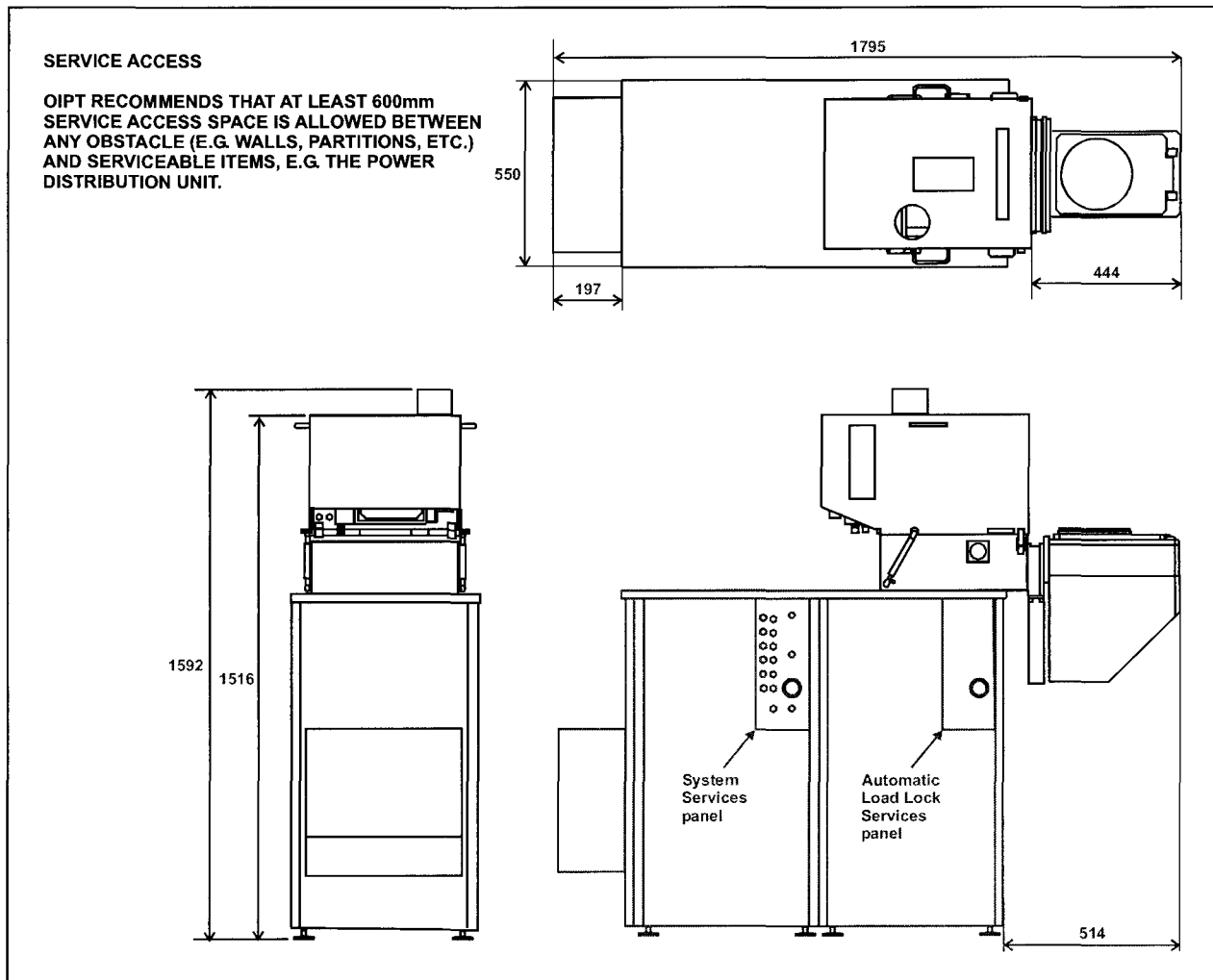

Fig 3: ICP 180 Layout (2-frame cluster upgradeable)

NOTE: For services panel details, see [Fig 4](#).

3. Services connections

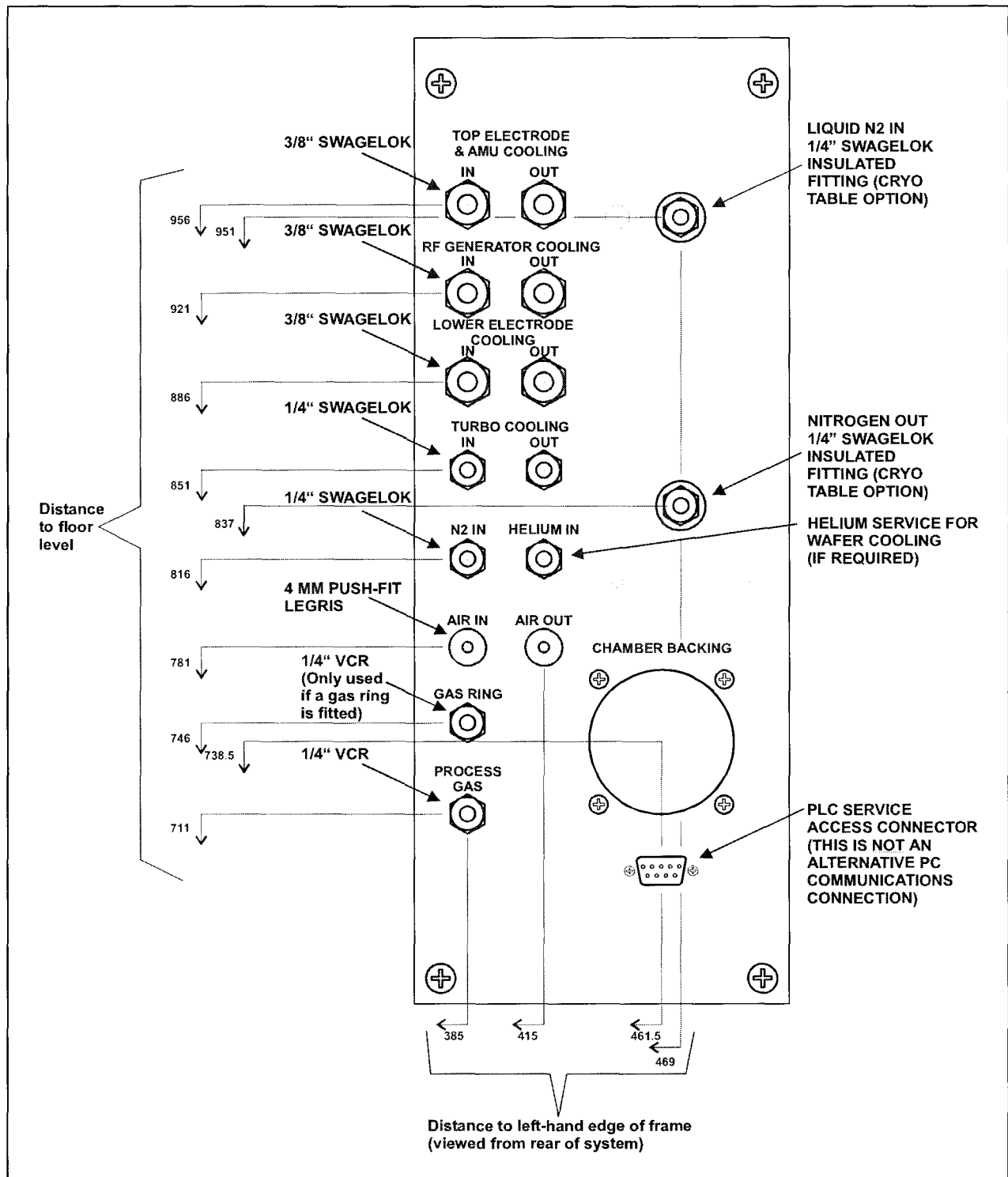

Fig 4: ICP 180 services panel

NOTE: The Automatic load lock services panel is similar to that shown above but only the CHAMBER BACKING connector is used.

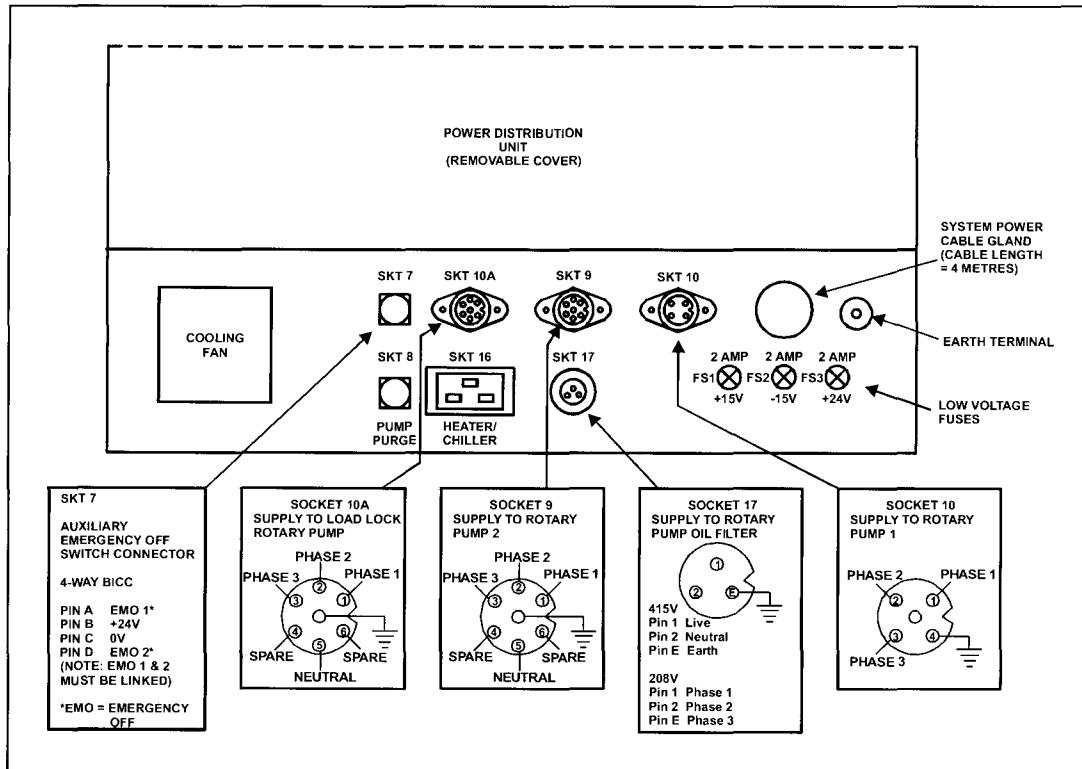

Fig 5: Electrical connections

4. Gas handling

IMPORTANT OIPT gas pods typically weigh >40kg. If you intend fixing your gas pod to a wall, ensure the wall and gas pod fixings are sturdy enough to bear at least four times the weight of the gas pod. Periodically, e.g. annually, check the gas pod and its fixings are secure.

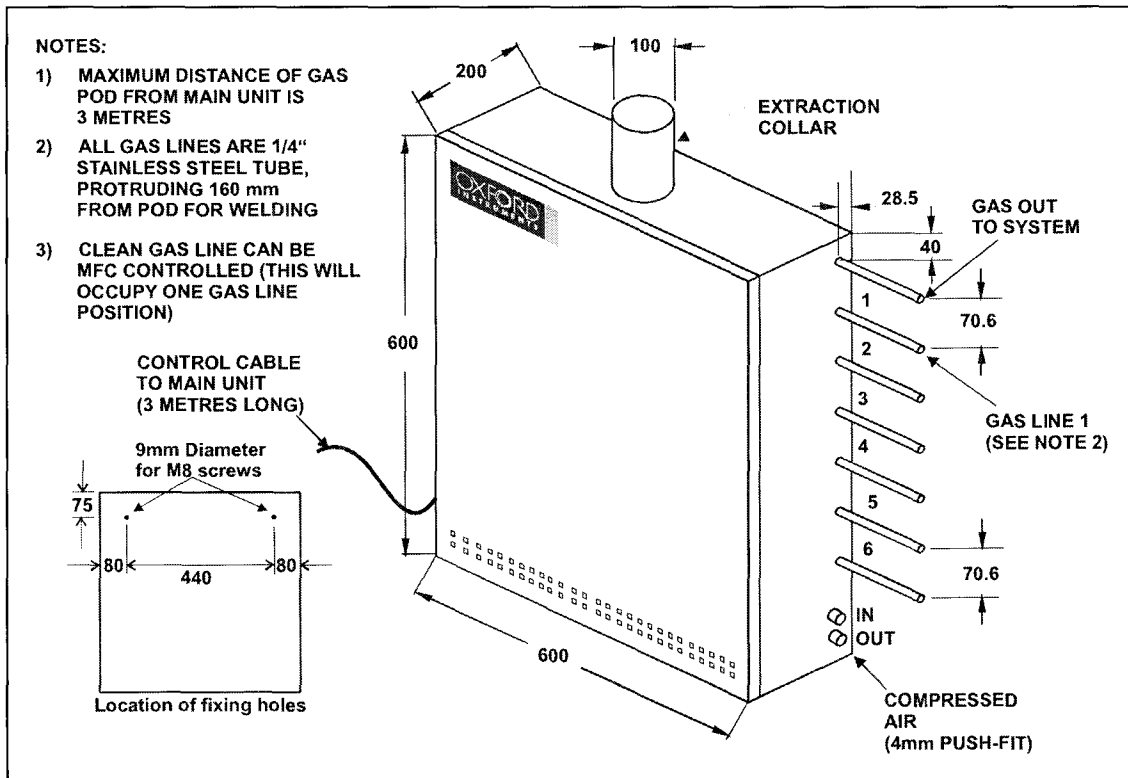

Fig 6: 6-line gas pod

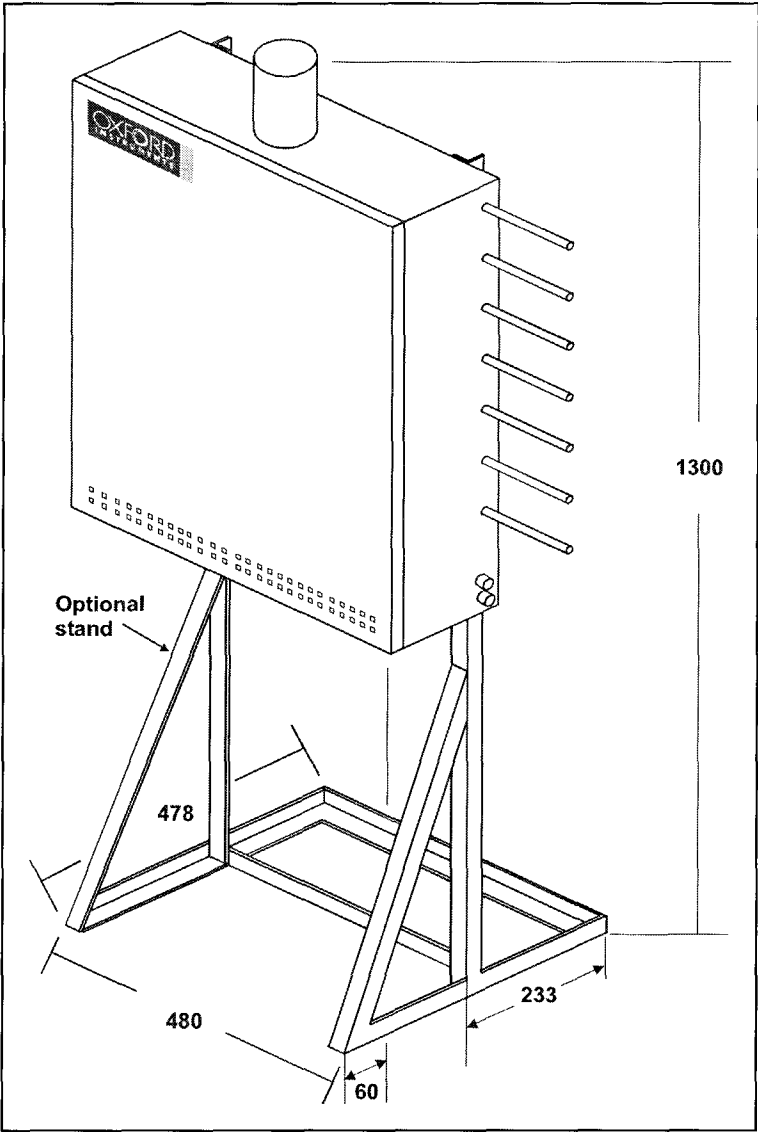

Fig 7: 6-line gas pod mounted on optional free-standing frame

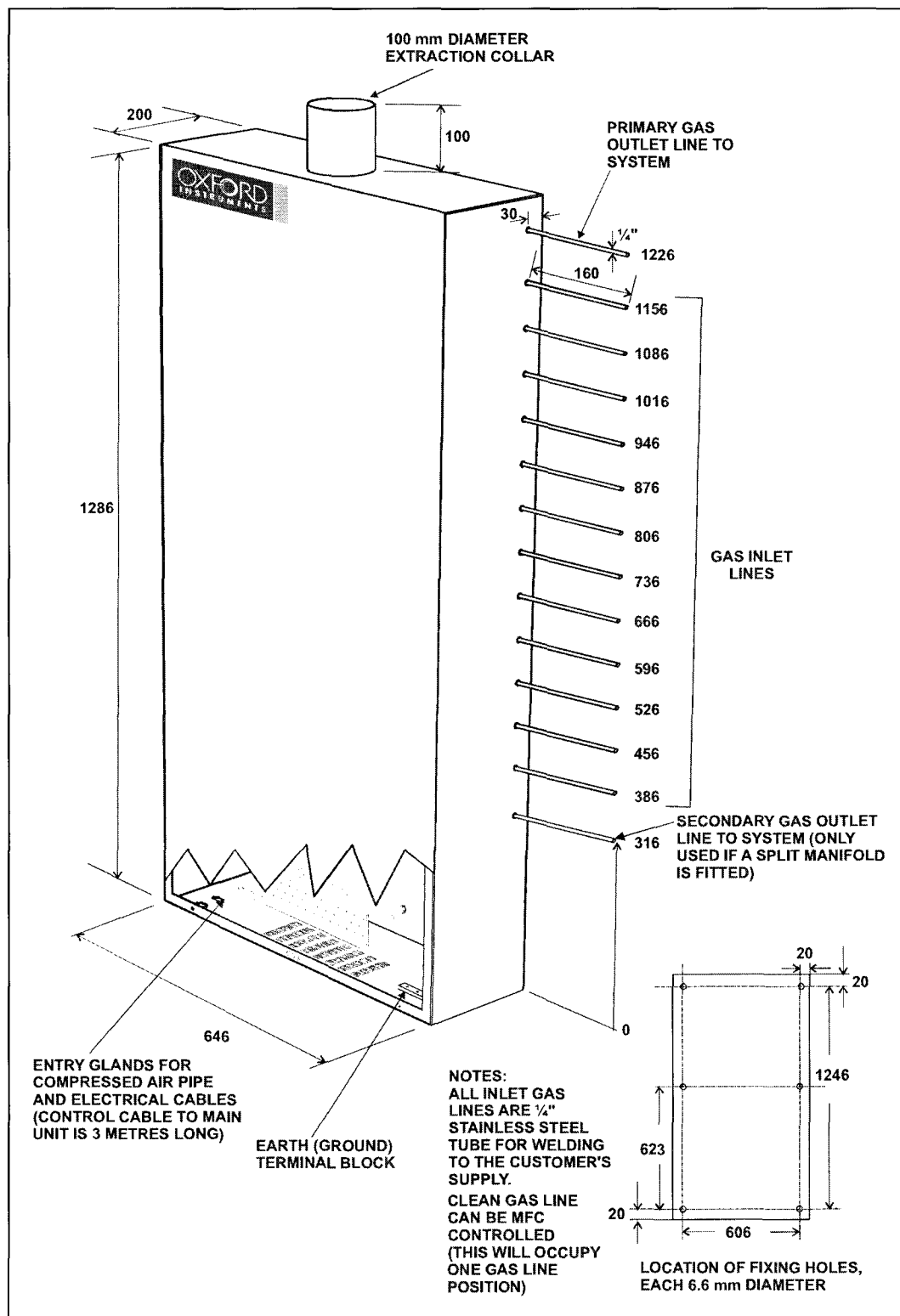

Fig 8: 12-line gas pod

5. Services

The required services are listed in the following sub-sections. For full details of services specifications including connection diagrams, electrical connection schematic etc., read in conjunction with the Oxford Instruments Plasma Technology 'Services Specifications for **Plasmalab** and **Ionfab** Systems' document.

5.1 Electrical Supply requirement

Function	Connection	Parameter	Specification
System electrical supply (208V system)	Cable (4 meters long)	Voltage	208Vac ±10%
		Current	50 A
		Frequency	50 / 60 Hz
		Phases	3 phase, N + E
System electrical supply (415V system)	Cable (4 meters long)	Voltage	380Vac -10% to 415Vac +6%
		Current	50 A
		Frequency	50 / 60 Hz
		Phases	3 phase, N + E

5.2 Water Cooling requirement

Function	Connection	Parameter	Specification
Process turbo	1/4" stainless steel Swagelok	Flow	1 lpm (0.27 gpm (US))
		Temperature	15 - 25°C (59 - 77°F)
RF Generator and ICP	3/8" stainless steel Swagelok	Flow	8 lpm (2.12 gpm (US))
		Temperature	10 - 25°C (50 - 77°F)
ICP & AMU	3/8" stainless steel Swagelok	Flow	2 lpm (0.53 gpm (US))
		Temperature	10 - 25°C (50 - 77°F)
Load lock turbo (if required)	1/4" stainless steel Swagelok	Flow	1 lpm (0.27 gpm (US))
		Temperature	15 - 25°C (59 - 77°F)

5.3 Lower Electrode Cooling requirement

Function	Connection	Parameter	Specification
Liquid cooled lower electrode	3/8" stainless steel Swagelok to heater / chiller unit	Flow	2 lpm (0.53 gpm (US))
		Temperature	As required by process
LN2 Cryo cooled lower electrode	1/4" stainless steel Swagelok to dewar	Flow	As required by process

5.4 Compressed Air requirement

Function	Connection	Parameter	Specification
System CDA	4mm push-fit Legris	Flow	5 lpm (0.2 cfm) (combined with gas pod)
		Pressure	4.0 – 6.0 Bar (60 – 90 psi)
Gas pod CDA	4mm push-fit Legris	Flow	5 lpm (0.2 cfm) (combined with system)
		Pressure	4.0 – 6.0 Bar (60 – 90 psi)

5.5 Nitrogen requirement

Function	Connection	Parameter	Specification
System N ₂	¼" stainless steel Swagelok	Flow	10 lpm (0.4 cfm)
		Pressure	3.0 Bar (45 psi) minimum
Rotary pump purge	¼" stainless steel Swagelok typically	Flow	Refer to sub-section 6.1 Rotary pump purging
		Pressure	Refer to sub-section 6.1 Rotary pump purging

5.6 Process gas requirement

Function	Connection	Parameter	Specification
Process gas in	¼" stainless steel welded pipe at gas pod, ¼" stainless steel VCR at system.	Pressure	2.0 – 3.0 Bar (30 – 45 psi)

5.7 Helium requirement

Function	Connection	Parameter	Specification
Helium in	¼" stainless steel Swagelok	Pressure	2.0 – 3.0 Bar (30 – 45 psi)

5.8 Extraction requirement

Function	Connection	Parameter	Specification
ICP180	100mm (4") tube	Flow	1 m ³ /hour (0.6 cfm)
Gas pod	100mm (4") tube	Flow	6-line gas pod – 1 m ³ /hour (0.6 cfm) 12-line gas pod – 3 m ³ /hour (1.8 cfm)
Rotary pump exhaust	Refer to Section 6 Pump set information		

6. Pump set information

CAUTION

Where the rotary vane or Roots pumps are powered from a mains supply separate from the PlasmalabSystem100, a separate 'emergency off' facility must be provided by the customer.

Available pump options	Length mm	Width mm	Height mm	Machine connection	*Pump outlet connection	Weight kg	Power consumption kW	Minimum N ₂ purge rate
Alcatel 2015C2	462	188	240	NW 25	NW 25	27	0.45 (50Hz) 0.55 (60Hz)	2 litres/minute
Alcatel 2033C2	701	213	348	DN 40	DN 40	76	1.1 (50Hz) 1.3 (60Hz)	2 litres/minute
Alcatel 2063C2	819	264	397	DN 40	DN 40	98	2.2 (50Hz) 2.6 (60Hz)	2 litres/minute
Alcatel ADP 122P	830	390	580	DN 50	DN 40	245	1.5	10 litres/minute
Alcatel ADS602P	830	390	580	DN 100	DN 40	378	1.8 (50Hz) 2.0 (60Hz)	10 litres/minute
Alcatel ACP 28G	609	185	310	DN 25	ISO K-F	33.5	1.2	1.05 litres/minute
Alcatel RSV 301	880	510	1000	DN 40	DN 63	220	1.1 (50/60Hz)	**2 litres/minute

* All fittings and pipework connected to the rotary pump exhaust must be made from industry standard stainless steel. Refer to the OIPT Services Specifications document, sub-section 8.1.

** This figure applies only to the rotary vane pump; the roots blower does not require N₂ purging.

6.1 Rotary pump purging

The requirements for rotary pump purging depend on the process used. Customers should consult the pump manufacturer for their recommendations.

For Alcatel 2033 and 2063 rotary pumps, the recommended minimum N₂ purge rate is 2 litres/minute at a pressure of 2bar to 5bar. For highly corrosive or pyrophoric gases, 4 litres/minute is recommended.

7. Heater/chiller information

Available heater/chiller options	Length mm	Width mm	Height mm	*Typical operational temperature range	Water connections	Weight kg	Electrical requirements
Neslab RTE-7	445	235	600	0°C to +90°C	¼" Swagelok fitted	28.6	230V 50Hz or 115V 60Hz, 12A single phase
Betta-Tech CU500	610	380	450	-10°C to +70°C	¼" Swagelok fitted	62	240V 50Hz 8.5A or 110V 60Hz 15A, single phase

*Standard control range, for other temperature ranges please consult the factory.

IMPORTANT: Heater/chillers should be filled/topped up with Hexid A40 coolant (Oxford Plasma Technology Part No. G/WTR/SUN/007 for 15 litres). This product is propylene glycol based and is pre-diluted ready for use. Refer the OIPT 'Services Specifications for Plasmalab and Ionfab systems' document, sub-section 2.1 for the warranty impact of not using this product.

8. Interlocks

There are two types of interlocks used on the **Plasmalab**System100; hardware and software. In all areas, the hardware interlock will override any software interlock. The hardware interlocks, and their effect on the system components in the case of an interlock becoming open circuit are as follows:

The electrical interlocks are divided into two circuits controlling the power to the system.

- 1) The mains power connection is made to a system Power Distribution Unit. The Power Distribution Unit will disable all of its power outputs under the following conditions:
 - a) If the Emergency Off button is pressed.
 - b) If there is an interruption of the power input to the system.
 - c) If the Power Distribution Unit external facility interlock sensor link becomes open circuit.

NOTE: The Power Distribution Unit external facility interlock sensor link enables the interlocks of external sensors, e.g. gas detectors, exhaust scrubbers, etc., to be monitored by the Power Distribution Unit. External interlock contacts connected to this link should be voltage free and Normally Closed, i.e. faulting to an Open Circuit.

- 2) The system internal 24V supply, comprises a process line and a chamber line:

The 24V process line, which controls the process gases and plasma power supply units, will be disabled under the following conditions:

- a) If the Vacuum Safety Switch is open circuit, i.e. Chamber Pressure > 600 mbar.
- b) If the load lock slit valve is OPEN.

The 24V chamber line will be disabled under the following conditions, leaving the system controller operational, but disabling all system components:

- a) If the Water Flow switch is not closed.
- b) If the Chamber top is OPEN.

Interlock	Emergency Off / Electrical Fail		24V Process line		24V Chamber line	
	Fail	Restore	Fail	Restore	Fail	Restore
System/Controller	OFF	Restart Required	ON		ON	
RF Generator	OFF	Powered, NOT active	OFF	Powered, NOT active	OFF	Powered, NOT active
Process Gases	OFF	Powered, NOT active	OFF	Powered, NOT active	OFF	Powered, NOT active
Automatic Pressure Controller Valve	CLOSED	CLOSED	NO CHANGE	NO CHANGE	CLOSED	CLOSED
Load lock Slit Valve	HOLD	HOLD	HOLD	HOLD	HOLD	HOLD
Pumps	OFF	Pumps must be restarted	NO CHANGE	NO CHANGE	OFF	Pumps must be restarted

Table 2 - Consequences of open circuit interlocks

The other component specific interlocks are incorporated into the software controller, alerting the operator of conditions such as low process gas flow, pump failure, etc. The software also monitors the position of the wafer handling mechanisms, ensuring safe operation.

9. OIPT locations worldwide

UK

Oxford Instruments Plasma Technology
North End, Yatton,
Bristol, BS49 4AP
Tel: +44(0)1934 837000
Fax: +44(0)1934 837001
Email: plasma.technology@oxinst.co.uk
Web: www.oxford-instruments.com/plmchp5.htm

USA

Oxford Instruments Inc.
130A Baker Avenue Extension
Concord, MA 01742
Tel: +1 978 369 9933
Toll Free +1 800-447-4717
Fax: +1 978 369 8287
Email: info@ma.oxinst.com

Germany

Oxford Instruments GmbH
Otto-von-Guericke Ring 10,
D-65205 Wiesbaden
Tel: +49(0)6122 937161
Fax: +49(0)6122 937175
Email: plasma@oxford.de

Japan

Oxford Instruments K.K.
2-11-6 Tomioka
Koto-ku, Tokyo 135-0047
Tel: +81-3-5245-3261
Fax: +81-3-5245-4466
Email: oikkpt@oxinst.co.jp
Web: www.oxford-instruments.jp

People's Republic of China (Beijing)

Oxford Instruments China
Room 714, Office Tower 3,
Henderson Center,
No. 18 Jianguomennei Ave,
Dongcheng District,
Beijing 100005
Tel: +86 106518 8160/1/2
Fax: +86 106518 8155
Email: ptsales@oichina.cn
Web: www.oxford-instruments.com.cn

People's Republic of China (Shanghai)

Oxford Instruments China
Room 14-F, No.1 Plaza
800 Nanjing East Road
Shanghai 200001
Tel: +86 216360 8530
Fax: +86 216360 8535
Email: ptsales@oichina.cn
Web: www.oxford-instruments.com.cn

Singapore

Oxford Instruments Pte. Ltd
371 Beach Road,
#02-07 Keypoint
Singapore 199597
Tel: +65 6337 6848
Fax: +65 6337 6286
Email: oipt.sales@oxford-instruments.com.sg

Taiwan

Oxford Instruments Overseas
Marketing Ltd.
1F, No 23 Jing-Shang 19th Street,
Hsinchu, Taiwan
Tel: +65 6337 6848
Fax: +65 6337 6286
Email: oipt.sales@oxford-instruments.com.sg

Appendix R Rotameter data

1 Rotameters	2
1.1 Rotameter types	2
1.2 Setting the required purge flow rate	3
1.3 Flow versus scale reading graphs	4
Fig 1: Typical rotameter	2

1 Rotameters

A rotameter is a manually controlled variable valve/indicating tube, used by OIPT to manually set the flow rate¹ for various gas supplies. For example, purge flow rates for turbomolecular², rotary vane and dry pumps, glove boxes and etch gas supplies for process chamber cleaning.

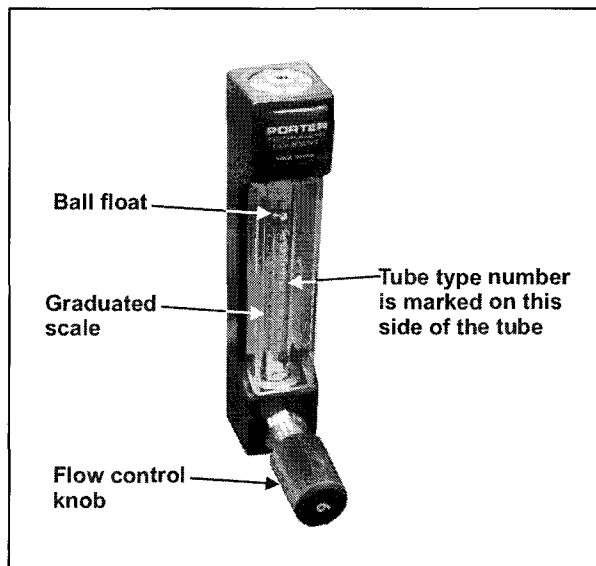

Fig 1: Typical rotameter

1.1 Rotameter types

The models of rotameter used for setting purge gas flows on OIPT equipment is fitted with a common scale, reading from 0 to 6 as flow is varied from zero to full scale. The full-scale flow depends on:

- The tube type (marked on the tube itself)
- The ball material
- The gas type
- Temperature
- Pressure

The full-scale flows given in the following table are for 20° C, 1 atmosphere pressure, air or nitrogen gas.

OIPT part	Tube number	Ball material	Normal use	Full scale flow
G/GAS/ROT/050	A125-3	Glass	Turbo pump purge	53 sccm
G/GAS/ROT/25L	A250-4	Carboloy	Rotary pump purge, PECVD	27.5 slpm
G/GAS/ROT/40L	A250-6	Stainless steel	Pump exhaust purge	43.4 slpm
G/GAS/ROT/800	A125-7	Stainless steel	CF ₄ /O ₂ 'clean gas' metering	850 sccm
G/GAS/ROT/900	A250-1	Stainless steel	Rotary pump purge, etch, PECVD	4.4 slpm

¹ Flow rates are quoted in either standard cubic centimetres per minute (sccm) or standard litres per minute (slpm).

² In most OIPT systems, turbomolecular pump purge flows are set automatically and monitored by the system software via a flow meter: these systems do not incorporate a rotameter for the turbo pump purge.

The flow-setting knob can be on the upstream or downstream side of the tube.

- If it is upstream (below the tube), the pressure in the tube is close to the exit pressure, which should be close to 1 bar absolute for pump or exhaust pipe purging.
- If the knob is downstream (above the tube) the pressure in the tube is close to the supply pressure of the gas. This method is normally used if the exit pressure is below atmospheric pressure, which is often the case in turbomolecular pump purging.

If in doubt, control downstream is always safe, because the ball float will operate normally and the purge flow will be slightly higher than given in the table.

1.2 Setting the required purge flow rate

CAUTION

The rotameter scale is graduated with values of 0 to 6. These graduations do not represent flow rates in sccm or slpm.

To set the required flow rate, use the following procedure.

Note that the following procedure is for setting N₂ purge flow rates for pumps; a similar procedure can be used for other applications, e.g. etch cleaning, glove box purging, etc.

To set the required flow rate, use the following procedure:

- 1) Refer to the pump manufacturer's literature or to the relevant OIPT Installation Data document to obtain the required N₂ flow rate.
- 2) Check the Tube number (marked on the Rotameter tube) and then refer to the relevant rotameter's graph on page 4 and note the required scale reading.
- 3) Ensure that the N₂ supply meets the Mandatory Requirements for Nitrogen Supplies as stated in the OIPT Services Specifications document sub-section 5.1.
- 4) Adjust the rotameter flow-setting knob so that the centre of the ball float is aligned with the required scale reading. (Rotate knob anti-clockwise to increase flow, clockwise to reduce flow.)

1.3 Flow versus scale reading graphs

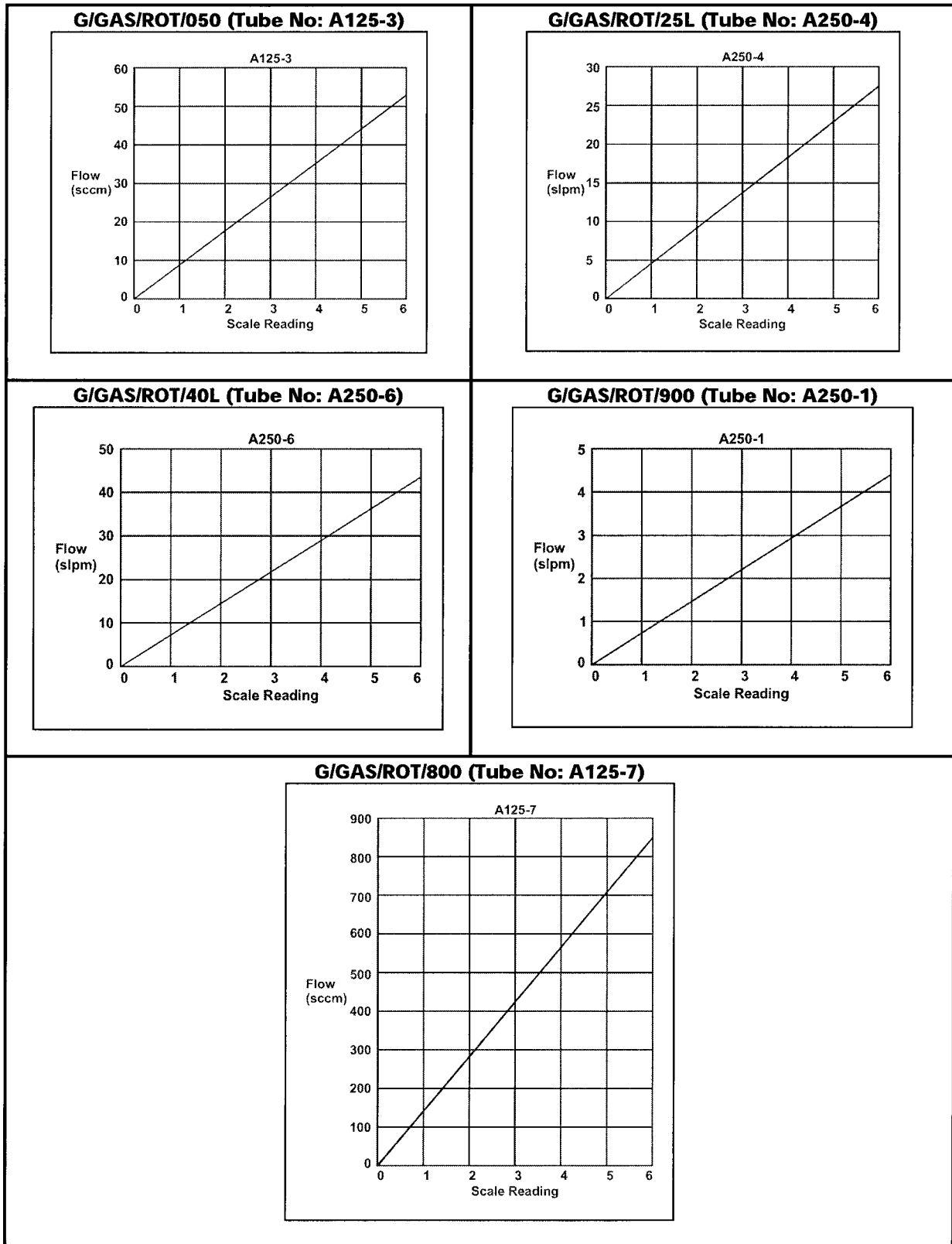

**Appendix S Qualitative Specifications for all of Oxford
Instruments Plasma Technology's Plasma and Ion
Beam Systems**

CONTENTS

1. Introduction	3
2. Cooling / Warming water	4
2.1 Recirculation water	5
2.1.1 Mandatory Specifications for recirculated water systems	6
2.2 Total Loss Cooling	7
2.2.1 Mandatory Specifications for total loss cooling systems	8
3. Electrical supply	9
3.1 System earthing and bonding	9
3.1.1 Earth connection	9
3.1.2 Neutral supply bonding	10
3.1.3 Residual Current Circuit Breakers	10
3.2 Mandatory Specifications for electrical installations	10
4. Compressed air	11
4.1 Mandatory Specifications for compressed air supplies	12
5. Nitrogen	13
5.1 Mandatory specifications for Nitrogen supplies	13
6. Process gases	14
6.1 Mandatory specifications for process gas supplies	14
6.1.1 Systems using Helium wafer cooling	14
6.1.2 Installation of low vapour pressure gases (e.g. SiCl ₄ , BCl ₃ , C ₄ F ₈)	15
7. Liquid Nitrogen	16
7.1 Mandatory Requirements for Liquid Nitrogen systems	16
8. Extraction	17
8.1 Mandatory requirements for Rotary Pump extraction	17
8.2 Mandatory requirements for Gas Pod extraction	17
8.3 Mandatory requirements for Cryogenic pump extraction	18
9. Environment	19
9.1 Mandatory Specifications for the system environment	19
10. Change Record	20
11. OIPT locations worldwide	22
Fig 2.1: Recommended basic recirculation installation	6
Fig 2.2: Recommended basic total loss installation	7
Fig 3.1: Recommended electrical installation	9
Fig 4.1: Recommended compressed air supply installation	11
Fig 5.1: Recommended nitrogen supply installation	13
Fig 6.1: Recommended process gas supply installation	14

1. Introduction

This document gives the specifications of the services required for the **Plasmalab** and **Ionfab** systems. For details of cooling flow rates and electrical supply ratings, see the relevant system installation data sheets.

Customers must ensure that the services as specified are available at the time of delivery to reduce system commissioning time and potential problems.

Unless other arrangements have been made in writing with Oxford Instruments Plasma Technology (OIPT), it is a requirement that services meet the following specifications. If they do not meet these specifications then the system warranty and process guarantees may be made invalid.

If you suspect that you may fail to meet **ANY** of these specifications, please contact Oxford Instruments Plasma Technology (OIPT) immediately so that we can discuss the problem with you.

Oxford Instruments Plasma Technology (OIPT) conducts a programme of continual product development, and reserves the right to change the design and/or specification of equipment without notice. The details contained in this document were correct at the time of printing but should be confirmed immediately prior to delivery.

WARNING

BEFORE INSTALLING THE SERVICES REQUIRED FOR OIPT SYSTEMS, ENSURE THAT ALL RELEVANT ASPECTS OF HEALTH AND SAFETY ARE FULLY UNDERSTOOD.

HEALTH AND SAFETY GUIDANCE AND INSTRUCTIONS ARE GIVEN IN SECTION 1 OF ALL OUR SYSTEM USER MANUALS. THIS DOCUMENT IS AVAILABLE IN ENGLISH, FRENCH, GERMAN AND JAPANESE.

2. Cooling / Warming water

There are two acceptable methods of applying cooling / warming water to an OIPT system:

Recirculation: Water is pumped through the system by a dedicated *heater / chiller or heat exchanger. After passing through the system, the temperature of the water is adjusted before recirculating through the system.

*Many customers have a water recirculation facility shared by several systems. This shared facility seldom provides water of suitable quality, and so cannot usually be used for cooling any part of the OIPT system without the use of a heat exchanger dedicated to the OIPT system.

Total Loss Cooling: Municipal (drinking quality) water is applied to the system from a mains supply, passed through the system to cool it, then fed to a drain for disposal.

Water failing to meet the recirculation or total loss cooling specifications must not be put into the system without close consultation with OIPT.

In some circumstances, it may be appropriate to use a combination of recirculation cooling and total loss cooling in one system.

It is recommended that the customer uses a dedicated heater/chiller either for the whole system, or at least for the critical components. Note that chillers, which cool only, can give problems with condensation on chamber components in some environments. This is a particularly important consideration for production systems of the batch-load type. In severe cases, they can produce sufficient condensation to damage components such as RF power supplies, ferrofluidic seals and automatch units. Any damage so caused cannot be covered by the system warranty.

Note that if a heater-chiller is used to provide warm water (above 30^o C) for heated parts of the system, then items such as the turbo pump will need an independent water supply.

Items such as turbomolecular pumps can be cooled with total loss cooling if they are of stainless steel construction and if the water is suitable. If the water is not suitable, then a heat exchanger may be necessary.

Total loss cooling cannot be used on any components that have aluminium in direct contact with the coolant. See sub-section 2.1.

2.1 Recirculation water

WARNING

CHILLERS HAVE COMPONENTS, WHICH BECOME COLD ENOUGH TO CAUSE SERIOUS INJURY. READ THE MANUFACTURER'S MANUALS BEFORE INSTALLING, OPERATING OR MAINTAINING CHILLERS, AND ENSURE THAT ADEQUATE PROTECTIVE CLOTHING IS WORN.

Recirculation water is used in systems where the user does not wish to consume water at a high rate, or where it is wished to supply water to the system at a constant temperature.

Some systems contain aluminium in direct contact with coolant. These are the **Ionfab 500 Plus**, the **Ionfab 300 Plus**, and **Plasmalab** systems fitted with tables or turbomolecular pumps with plain aluminium cooling channels. Certain aluminium chambers are also included. However, the **Ionfab 300 Plus** does not contain aluminium in contact with water, unless it is in the turbomolecular pump.

In these aluminium-containing systems, it is MANDATORY that the approved coolant is used at all times. If the approved coolant and installation are not used, the system warranty will not cover any damage caused by the coolant either directly or indirectly to the system or to anything else.

It is the customer's responsibility to comply with the above requirement. If the customer has any doubt as to whether their system falls into this category, they must contact OIPT for further advice.

In systems that do not contain aluminium components, severe corrosion can still sometimes occur: water will collect corrosive chemicals, and will be lacking in the oxygen that protects stainless steel. We strongly recommend that the approved coolant is used. If an alternative product or water is used, then it is entirely the customer's responsibility to check for any signs of corrosion or contaminated water. If the customer's coolant has not been approved in writing by OIPT, then the system warranty will not cover any damage caused by the coolant either directly or indirectly to the system or to anything else¹.

The approved installation and coolant are shown in sub-section 2.1.1 and in Fig 2.1. Note that the total water flow meter and the isolation valves are recommended for cooling monitoring and ease of maintenance.

¹ Customers should note, for example, that certain types of inhibitor will damage the pumps of heater/chiller units, and that the use of municipal (drinking water) or deionized water can introduce harmful chemicals into the system. If plain water is used, distilled water is by far the safest option.

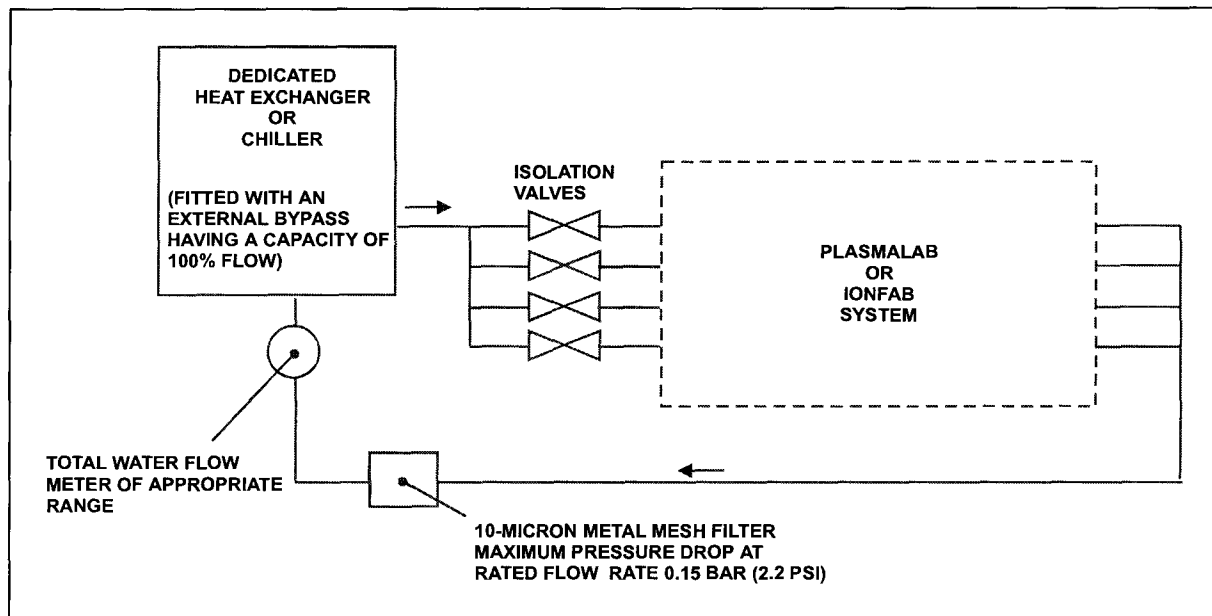

Fig 2.1: Recommended basic recirculation installation

2.1.1 Mandatory Specifications for recirculated water systems

CAUTION

If clear (i.e. transparent) tubing is exposed to sunlight, algal growth can develop, which can restrict coolant flow.

It is MANDATORY that clear tubing is not used in any part of the cooling system. OIPT recommends the use of either black or dark green tubing.

CAUTION

It is the customer's responsibility not to exceed a pressure of 4.2 bar, or other limit that has been set for the system. Exceeding this safe pressure may cause irreparable damage to system components.

The water must be kept warm enough to prevent condensation on chamber surfaces and outside system components. This applies to those parts of the system inside the clean room and those parts in a service area. Condensation can damage components such as RF power supplies, ferrofluidic seals and automatch units. Any damage so caused cannot be covered by the system warranty.

Pressure:	Adjustable 0.7 to 4.2 bar (10 to 60 psi). Chiller / heat exchanger to be fitted with a bypass having a capacity of 100% of rated flow.
Temperature range:	See system installation data sheets.
Minimum flows:	See system installation data sheets.
Cooling capacity:	See system installation data sheets.
Coolant:	Hexid A40 (OIPT Part No. G/WATER/SUN/007 for 15 litres)². This product is propylene glycol based, and is pre-diluted ready for use. See sub-section 2.1 for the warranty impact of not using this product.
Filtration:	10 micron metal mesh water filter. Maximum pressure drop 0.15 bar (2.2 psi) at rated flow. For example, filter element Balston SMC-100-12-10.

2.2 Total Loss Cooling

Municipal (drinking) water may be used in total loss cooling of the system in situations where clean water is freely available, but only if the water meets the specification in sub-section 2.2.1. In case of any doubt, obtain the water specification from the water utility company, and consult with OIPT. It is not practical to use total loss cooling where the water temperature is critical.

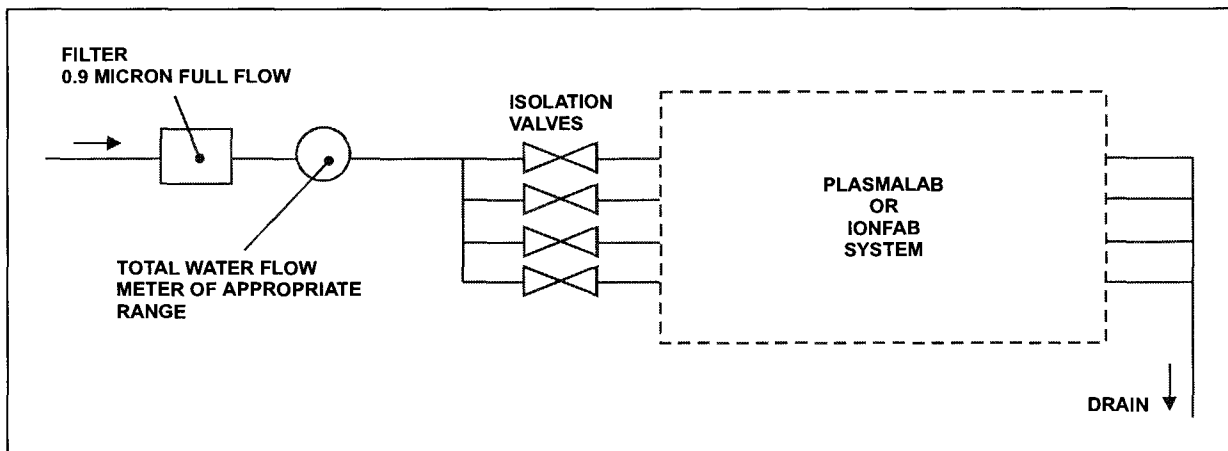

Fig 2.2: Recommended basic total loss installation

² To order replacement fluid, check the capacity of the model of heater/chiller to be fitted to the system. Also allow at least 5 litres for the system and connecting lines, or more if necessary.

2.2.1 Mandatory Specifications for total loss cooling systems

CAUTION

If clear (i.e. transparent) tubing is exposed to sunlight, algal growth can develop, which can restrict coolant flow.

It is MANDATORY that clear tubing is not used in any part of the cooling system. OIPT recommends the use of either black or dark green tubing.

CAUTION

It is the customer's responsibility not to exceed a pressure of 5 bar, or other limit that has been set for the system. Exceeding this safe pressure may cause irreparable damage to system components.

If total loss cooling with municipal water (drinking quality water) is used in the system or in the pumps, the water quality must meet the following specifications. Note that increased maintenance will be required if this water is used directly in the system as well as in the pumps.

The water must be kept warm enough to prevent condensation on chamber surfaces and outside system components. This applies to those parts of the system inside the clean room and those parts in a service area. Condensation can damage components such as RF power supplies, ferrofluidic seals and automatch units. Any damage so caused cannot be covered by the system warranty.

• Pressure:	4 to 5 bar. Backpressure from the drain must be less than 1 bar.
• Temperature:	10°C to 25°C
• pH:	7 to 8
• Oxygen:	Greater than 4mg/litre
• CO₂ and NH₃:	Less than 10mg/litre
• Chloride:	Less than 100mg/litre
• Calcium Carbonate:	Less than 75mg/litre
• Filtration:	To 0.9 micron full flow, for example filter element Balston 200-50-50 or 200-95-50.

3. Electrical supply

Classification: For European Community customers who need this information: The systems are classified as Class A, Group 2 as defined in EN 55011 Clause 4.

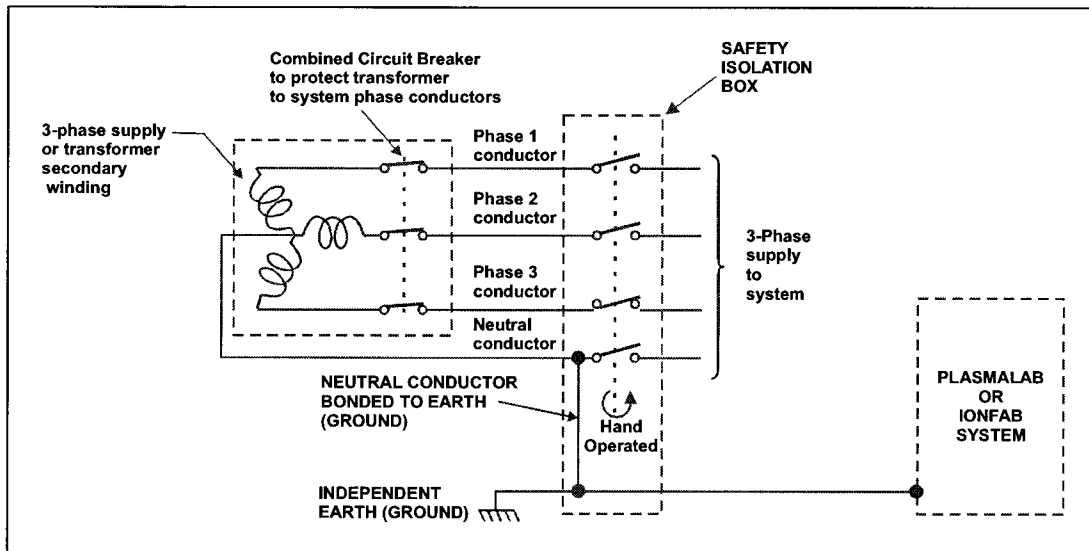

Fig 3.1: Recommended electrical installation

- NOTES:**
- The combined Circuit Breaker **MUST** break all phases if any one phase exceeds the set current limit.
 - The trip rating of the Circuit Breaker depends on the system type and the supply voltage to the system.
 - The current-carrying capacity of the cables between the Circuit Breakers and the system must be greater than the trip rating of the Circuit Breaker.

For example, if a 32A Circuit Breaker is fitted then a cable having conductors of a minimum rating of 40A (32A x 125%) is required. The conductors will have a minimum Cross Sectional Area (CSA) of 6.0 mm².

3.1 System earthing and bonding

3.1.1 Earth connection

To meet international standards for RF interference, our systems are fitted with filtration on the mains supply inputs. As a result, there is significant leakage to earth (ground) from the mains supply.

WARNING

IT IS ESSENTIAL THAT AN EARTH CONNECTION IS MADE BEFORE CONNECTING THE SUPPLY.

International standard IEC950, section 5.2, requires that a label is attached at the point where the system is connected to the factory electricity supply: either to the safety isolation box, or to the transformer, or to the electrical supply outlet socket. This label must contain the following text:

**"WARNING.
High leakage current.
Earth connection essential before connecting supply."**

3.1.2 Neutral supply bonding

WARNING

THE NEUTRAL CONDUCTOR MUST BE BONDED TO THE EARTH (GROUND) CONDUCTOR. IF THIS IS NOT DONE ALREADY IN THE FACTORY SUPPLY, THEN IT MUST BE DONE AT THE SAFETY ISOLATION BOX AS SHOWN IN Fig 3.1. IF AN ISOLATING TRANSFORMER IS FITTED, THEN THE NEUTRAL CONDUCTOR OF THE TRANSFORMER SECONDARY MUST BE BONDED TO THE EARTH (GROUND) CONDUCTOR.

3.1.3 Residual Current Circuit Breakers

Customers sometimes wish to fit a Residual Current Circuit Breaker (RCCB), also known as an Earth Leakage Circuit Breaker (ELCB, or ELB) to the electrical supply to the system. This is not recommended for this type of equipment, and a 30mA breaker is likely to trip often, due to the leakage caused by the filters on the power lines. This leakage is in accordance with International standard IEC950 section 5.2.

- a) If you must fit an ELB, we strongly recommend a minimum current of 100mA.
- b) Even a 100mA circuit breaker may trip, and we accept no responsibility if this turns out to be the case.

3.2 Mandatory Specifications for electrical installations

• Connection:	In accordance with local regulations via a safety isolation box, lockable in the OFF position, mounted adjacent to the machine.
• Configuration:	3-phase, star ("Y") with a grounded neutral supply connected to the centre point. An independent earth (ground) is required.
• Maximum Current:	The Maximum Current required by the system is given in the relevant system installation data sheets.
• Voltage & Frequency:	380V -10% to 415V +6% or 208V +/-10% phase-to-phase. Frequency to be 50Hz or 60Hz. Note that voltage and frequency cannot be changed from the values specified at the time of ordering.
• Safety Earthing:	The system safety earthing must be in accordance with local Electrical Regulations. See Fig 3.1.

4. Compressed air

A dry and clean compressed air supply at a **minimum pressure** of 6 bar (90 psig) must be fed to a customer-supplied air filter/mist separator/pressure regulator unit mounted adjacent to the machine. A suitable unit is supplied by SMC (part No. AC 2030); other units to the same specification can be used. **Maximum safe pressure** in the customer's feed to the regulator is determined by the regulator used (9.9 bar (148.5 psig) for the SMC unit).

The supply to the system must be monitored by a pressure gauge having a range of 0 to 10 bar (0 to 150 psi). The pressure regulator must be fitted with a stop to prevent a pressure greater than 6 bar from being supplied to the system. The pressure to be used will be set during commissioning of the system.

The following air filter/mist separator/pressure regulator unit components are recommended:

Air filter:	SMC AF2000-02D with filter element 1129116A.
Mist separator:	SMC AFD2000-02D with filter element 63092. This filter element must be changed annually. Note that as this item is not supplied by OIPT, its maintenance is not included in the system manuals.
Regulator with gauge:	SMC AR2001-02G.
Spacers:	2 off SMC Y20L.

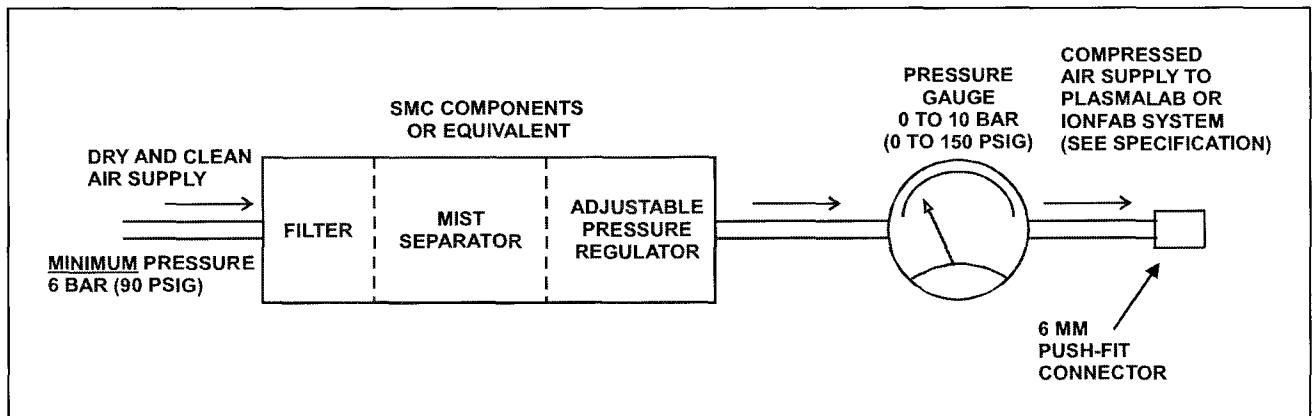

Fig 4.1: Recommended compressed air supply installation

4.1 Mandatory Specifications for compressed air supplies

• Inlet pressure to filter/mist separator/regulator unit:	6 bar (90 psig) <u>minimum</u>.
OUTLET TO SYSTEM:	
• Oil content:	Less than 10 ppm
• Maximum Moisture Content:	-3°C (25°F)
• Filtration:	Maximum particle size of 0.3 microns
• Regulator outlet pressure:	Adjustable from 3 bar to 6 bar (45 psig to 90 psig). 6 bar must be the maximum provided.
• Maximum flow rate:	135 litres/minute (5 scfm).
• Pressure monitoring:	0 to 10 bar (0 to 150 psi) pressure gauge.

5. Nitrogen

Nitrogen is required to vent and purge process chambers, load locks and pumps.

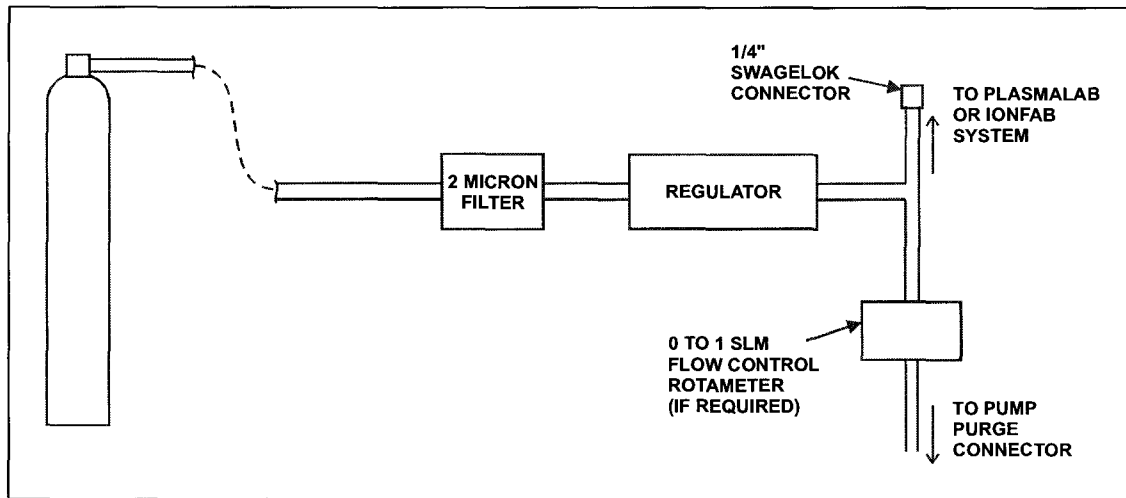

Fig 5.1: Recommended nitrogen supply installation

Semiconductor grade fittings and pressure regulators, together with electropolished stainless steel tube must be used to ensure that gas quality is not degraded. Purges to turbo pumps are supplied by OIPT as part of the system. The customer will usually need to fit a purge to the rotary pump. See below.

5.1 Mandatory specifications for Nitrogen supplies

• Pipework fittings and pressure regulators:	Semiconductor grade
• Gas handling tubing:	Electropolished stainless steel
• Purity:	At least 99.99% or higher to satisfy process requirements.
• Filtration:	2 micron filter mounted adjacent to the system.
• Regulation:	0.5 to 5 bar (7.5 to 75 psig)
• Minimum pressure at input to system:	3 bar (45 psig). Certain pumps, for example Edwards Drystar pumps, may need up to 5 bar (75psig) to ensure satisfactory purging. Check with the vendor's instructions.
• Rotary pump purging	<p>It is the customer's responsibility to ensure that a rotary pump purge connection is fitted and used correctly. This is needed to ensure the protection of the pumping system from the customer's process, and may also be required by local safety regulations. Because customers' requirements vary, components are not supplied automatically by OIPT. Kits of parts are available if required. Contact OIPT for further information.</p> <p>It may be safe to omit this feature on certain systems, such as Ionfab machines running inert gas processes. However, unless the customer has written agreement on this point from OIPT, any damage caused by the omission cannot be covered by the system warranty.</p>

6. Process gases

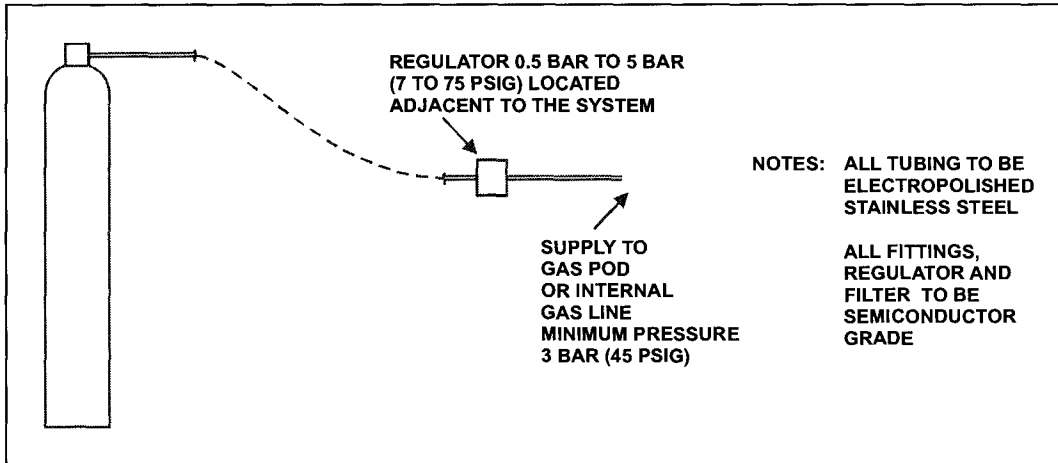

Fig 6.1: Recommended process gas supply installation

Semiconductor grade fittings and pressure regulators, together with electropolished stainless steel tube must be used to ensure that gas quality is not degraded.

6.1 Mandatory specifications for process gas supplies

• Pipework fittings and pressure regulators:	Semiconductor grade
• Gas handling tubing:	Electropolished stainless steel
• Purity:	At least 99.99% or higher to satisfy process requirements.
• Filtration:	A 2-micron filter is fitted to each gas line supplied as part of the system. For other grades of filter, please consult OIPT.
• Regulation:	0.5 to 5 bar (7.5 to 75 psig)
• Minimum pressure at input to system:	2 bar (30 psig)

6.1.1 Systems using Helium wafer cooling

The specifications for the Helium gas supply are as for those of the process gases given in sub-sections 6 and 6.1 **with the exception that the maximum pressure at the inlet to the pressure controller must not exceed 3.5 bar (43 psig)**. The design of the Helium pressure controller is such that it can be destroyed by higher pressures.

6.1.2 Installation of low vapour pressure gases (e.g. SiCl_4 , BCl_3 , C_4F_8)

The low vapour pressure can lead to condensation in the gas supply lines, particularly at cold points or when the gas passes into a cooler region. This condensation can result in a build up of liquid in the gas pipe, usually at the low points or u-bends in the gas line, often leading to instability of gas flow, especially if liquid condenses or flows into the MFC.

The low vapour pressure can also result in very low gas pressure if the gas cylinder is very cold, e.g. if it is kept outdoors in the winter.

Therefore, it is important to adhere to the following guidelines:

- (A) It is necessary to keep the gas cylinder indoors (in an extracted gas cabinet) to avoid loss of line pressure when the outside temperature is cold.

However, do NOT heat the gas cylinder with a heated jacket as this can cause condensation problems when the gas passes into the cooler gas lines. Room temperature is warm enough to provide sufficient vapour pressure.

- (B) It is important to maintain a positive temperature gradient from the cylinder to the MFC, or at least keep them at the same temperature. The simplest method is to position the gas cabinet close to the gas pod, minimising the chances of temperature differences, reducing the length of the gas pipe, and hence minimising the chances of condensation. If this is not possible, then it is necessary to heat the gas lines by the use of heater tape.

The MFC will also need to be heated. OIPT offers a heated MFC kit for these gases. Alternatively, heater tape can be wrapped around the MFC. However, in this case, it may also be necessary to detach the MFC from the backing plate to avoid heat loss through the plate, and to cover the MFC in insulation material to avoid cooling from air flow within the gas pod (from the gas pod exhaust).

It will then be necessary to set the MFC temperature hotter than the gas line temperature, which in turn is hotter than the gas cylinder temperature. A typical set-up might be MFC 40 °C or above, gas line 30-40 °C, and gas cylinder at room temperature.

- (C) If condensation problems are suspected, it will be necessary to pump out the gas lines completely, and optimise the heater tape arrangement and temperature setpoints before refilling the gas line.
- (D) For SiCl_4 it is important to use a dedicated SiCl_4 MFC as this is designed specifically for low-pressure condensable SiCl_4 operation.

7. Liquid Nitrogen

WARNING

IF LIQUID NITROGEN FACILITIES ARE NOT INSTALLED, OPERATED AND MAINTAINED CORRECTLY, DANGEROUS SITUATIONS CAN RESULT. THESE INTRODUCE RISKS OF:

- A) HAZARDOUS PRESSURE BUILD-UP CAUSED BY THE BOIL-OFF OF LIQUID NITROGEN, WHICH CAN RESULT IN AN EXPLOSION.**
- B) PERSONAL INJURY FROM TOUCHING PIPEWORK OR OTHER SYSTEM COMPONENTS CARRYING LIQUID NITROGEN. THIS RISK CAN REMAIN EVEN AFTER VENTING THE CHAMBER.**
- C) ASPHYXIATION CAUSED BY THE BOILED-OFF LIQUID NITROGEN REPLACING OXYGEN IN THE SYSTEM ENVIRONMENT.**

7.1 Mandatory Requirements for Liquid Nitrogen systems

- **Ensure that the Liquid Nitrogen installation is carried out in accordance with local safety regulations. This includes the following:**
 - (a) No part of the Liquid Nitrogen circuit can become blocked with ice or other contaminants.**
 - (b) Adequate precautions, e.g. pressure relief valves, are fitted to prevent hazardous pressure build-up from boil-off of the Liquid Nitrogen.**
 - (c) All system components carrying Liquid Nitrogen are adequately insulated, and covered to prevent personnel touching exposed components.**
- **Ensure that the installation is inspected by a Specialist to confirm that it is safe to use. Inspections must be carried out before the system is commissioned and at regular intervals throughout its life.**
- **Pipework from the Dewar to the system must be adequately insulated and connected to the system via a $\frac{3}{8}$ " Swagelok connector.**

8. Extraction

The following mandatory requirements describe the extraction systems recommended by OIPT. While these recommendations may be regarded as "good practice", they are not a complete definition of the safety standards required when handling toxic, corrosive or otherwise hazardous gases. It is the customer's responsibility to ensure that the installation meets all relevant local safety regulations and OIPT accepts no responsibility in this respect.

For detailed information about the safety aspects of gas handling and pumping systems, the customer should consult the relevant manufacturer/supplier of the gases and pumps to be used.

8.1 Mandatory requirements for Rotary Pump extraction

The installation must provide a rotary pump exhaust extraction system which matches the rotary pump exhaust and which conforms to local safety standards.

In particular, all fittings and pipework connected to the rotary pump exhaust must be made from industry standard stainless steel in accordance with local safety regulations.

Specialised equipment such as scrubbers and furnaces may be needed to dispose of hazardous gases. The routing of the pump exhaust line must be arranged so that condensates cannot flow back into the pump.

Note that there is a risk of damage from cross-contamination if rotary pumps share one exhaust system. This applies whether the pumps are on the same system or on different systems. Damage caused by any cross-contamination is not covered by the system warranty.

Care must be taken to route mutually incompatible exhaust gases through separate exhaust ducts. In particular, oxygen enriched exhaust gases should not be mixed with exhausts from mineral oil pumps, otherwise, an explosion may occur.

8.2 Mandatory requirements for Gas Pod extraction

The gas pod must be connected to the customer's gas extraction system via a 100 mm diameter pipe collar to provide cabinet extraction with a minimum flow rate of 1 m³/hour (6-line gas pod) or 3 m³/hour (12-line gas pod), i.e. an extraction vacuum of approximately 500 Pa relative to local atmospheric pressure is required. It is the customer's responsibility to ensure that the gas extraction system, including any necessary gas sensors, meets local safety regulations.

8.3 Mandatory requirements for Cryogenic pump extraction

WARNING

ANY CRYOGENIC PUMP, WHICH PUMPS HAZARDOUS GASES MUST HAVE, A VENT PIPE FITTED TO ITS RELIEF VALVE TO PREVENT THE RELEASE OF GAS INTO THE CLEAN ROOM.

THE PUMPS COLLECT THE PROCESS GASES AND THE GASEOUS RESIDUES DURING OPERATION. THESE GASES ARE RELEASED THROUGH THE RELIEF VALVE DURING PUMP REGENERATION OR IF ELECTRICAL POWER IS LOST.

If a cryogenic pump is used to pump toxic, corrosive, or flammable gases, a written action plan is required. This must be prepared in consultation with OIPT and other competent bodies. Specialised equipment such as scrubbers and furnaces may be needed to dispose of hazardous gases.

If the pumped gases contain more than 20% oxygen, a vent pipe must be fitted to the system's cryo pump outlet connector. The vent pipe must be routed to a safe place outside of the clean room and conform to local safety standards.

If a cryogenic pump is used to pump gases containing more than 20% oxygen, the associated roughing pump(s) must be lubricated with a PFPE fluid, e.g. Fomblin or Krytox.

9. Environment

9.1 Mandatory Specifications for the system environment

Rated for use in a Pollution Degree 1 Installation Category environment (laboratory or clean industrial environment).

• Operating temperature:	5°C to 25°C.
• Storage temperature:	0°C to 50°C.
• Maximum humidity:	90% See NOTE 1.
• Minimum humidity:	10% See NOTE 2.
• Electrostatic build-up:	Low static environment. See NOTE 2.
• Ambient light level:	300 lux minimum.

NOTE 1: High humidity will have a progressively significant effect on system performance. At humidity greater than 50%, the rate of chamber pump-down after venting the chamber will be affected significantly, and at humidity greater than 65%, the rate of chamber pump-down may not meet system specifications.

NOTE 2: Low humidity will introduce a risk of electrostatic build-up, with subsequent discharge to the system producing a malfunction or damage. The systems are tested to EN60801-2, severity level 3. We recommend the use of an environment, which protects against electrostatic build-up, and extra precautions will be necessary at low humidity.

NOTES:

11. OIPT locations worldwide

UK

Oxford Instruments Plasma Technology
North End, Yatton,
Bristol, BS49 4AP
Tel: +44(0)1934 837000
Fax: +44(0)1934 837001
Email: plasma.technology@oxinst.co.uk
Web: www.oxford-instruments.com/plmchp5.htm

USA

Oxford Instruments Inc.
130A Baker Avenue Extension
Concord, MA 01742
Tel: +1 978 369 9933
Toll Free +1 800-447-4717
Fax: +1 978 369 8287
Email: info@ma.oxinst.com

Germany

Oxford Instruments GmbH
Otto-von-Guericke Ring 10,
D-65205 Wiesbaden
Tel: +49(0)6122 937161
Fax: +49(0)6122 937175
Email: plasma@oxford.de

Japan

Oxford Instruments K.K.
2-11-6 Tomioka
Koto-ku, Tokyo 135-0047
Tel: +81-3-5245-3261
Fax: +81-3-5245-4466
Email: oikkpt@oxinst.co.jp
Web: www.oxford-instruments.jp

People's Republic of China (Beijing)

Oxford Instruments China
Room 714, Office Tower 3,
Henderson Center,
No. 18 Jianguomennei Ave,
Dongcheng District,
Beijing 100005
Tel: +86 106518 8160/1/2
Fax: +86 106518 8155
Email: ptsales@oichina.cn
Web: www.oxford-instruments.com.cn

People's Republic of China (Shanghai)

Oxford Instruments China
Room 14-F, No.1 Plaza
800 Nanjing East Road
Shanghai 200001
Tel: +86 216360 8530
Fax: +86 216360 8535
Email: ptsales@oichina.cn
Web: www.oxford-instruments.com.cn

Singapore

Oxford Instruments Pte. Ltd
371 Beach Road,
#02-07 Keypoint
Singapore 199597
Tel: +65 6337 6848
Fax: +65 6337 6286
Email: oipt.sales@oxford-instruments.com.sg

Taiwan

Oxford Instruments Overseas
Marketing Ltd.
1F, No 23 Jing-Shang 19th Street,
Hsinchu, Taiwan
Tel: +65 6337 6848
Fax: +65 6337 6286
Email: oipt.sales@oxford-instruments.com.sg

Plasmalab

ICP 180 Inductively Coupled Plasma Source

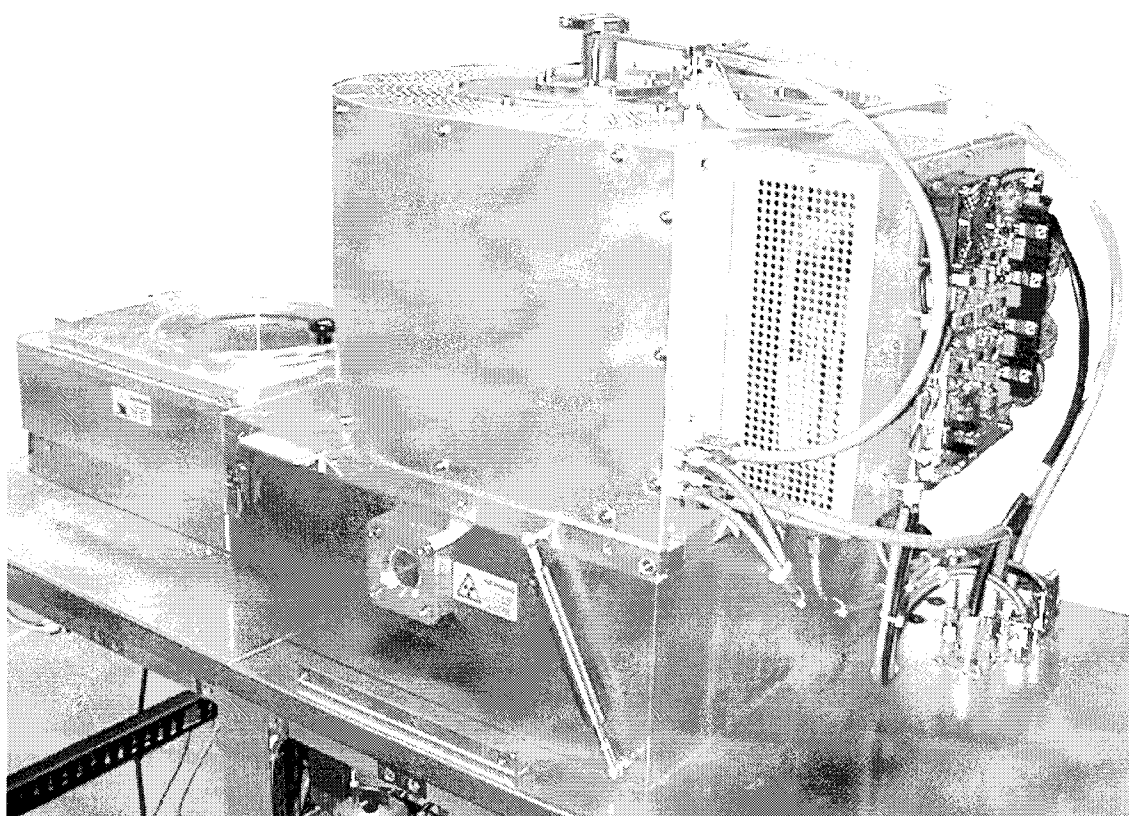

ICP 180 source fitted to a Plasmalab System 100

Contents

1. Health and Safety	3
2. Services	4
2.1 Qualitative requirements	4
2.2 Quantitative requirements	4
2.2.1 Cooling water.....	4
2.2.2 Process gas.....	4
2.2.3 RF power.....	4
2.2.4 Electrical supply.....	4
2.2.5 Extraction	4
3. Description	5
3.1 Function.....	5
3.2 Mechanical assembly	7
3.3 Source specification.....	8
3.4 Graphs of typical operating characteristics	9
4. Installation	11
5. Operating Instructions	12
5.1 Introduction	12
5.1.1 Manual adjustment of the Automatch Unit	12
5.1.2 Obtaining a Plasma.....	13
6. Maintenance	15
6.1 Maintenance schedule	15
6.2 Safety maintenance.....	15
6.2.1 Inspection and renewal	16
6.3 Routine maintenance	17
6.3.1 As required	17
6.3.2 Weekly	18
6.3.3 3-Monthly	18
6.4 Changing the ICP180 dielectric tube.....	19
7. Troubleshooting	21
7.1 Customer Support Facilities	21
7.2 High reflected power initial checks.....	22
7.3 High reflected power (system under vacuum)	23
7.3.1 Automatch gives reflected power > 5%	23
7.3.2 Automatch gives reflected power of 2% to 5%.....	24
OIPT locations worldwide	26
Fig 1: ICP 180 source - cross section of principal components.....	5
Fig 2: ICP 180 Exploded view	7
Fig 3: Ion current density at the wafer versus ICP power	9
Fig 4: Operating window	10
Fig 5: Typical AMU control panel	12
Fig 6: Automatch components	25

1. Health and Safety

For Health and Safety aspects of operating and maintaining the ICP 180 source, refer to Section 1 - Health and Safety of the **Plasmalab** System100 manual.

2. Services

2.1 Qualitative requirements

The qualitative services requirements for the **Plasmalab** ICP 180 source are given in Appendix S - 'Services Specifications for **Plasmalab** and **Ionfab** Systems'. This document gives generic information and mandatory requirements for all services.

2.2 Quantitative requirements

2.2.1 Cooling water

The source has two cooling circuits:

¼ inch pipework circuit requiring 1 litre/minute

$\frac{3}{8}$ inch pipework circuit requiring 2 litres/minute

The $\frac{3}{8}$ inch circuit can be put in series with the RF generator cooling provided the minimum flows of both are satisfied.

Cooling water is required at a minimum flow rate of 2 litres/minute to the source. The RF generator requires 4 litres/minute (1200W) or 8 litres/minute (3000W).

2.2.2 Process gas

Process gas supplies are required for the source and for the process chamber. Types of gases and their flow rates depend on the process application. Normally all gas is injected at the top of the source. A few processes (especially PECVD processes) require some of the gas to be injected downstream.

2.2.3 RF power

An RF generator is required to supply power to the automatch unit. The RF generator should have an output impedance of 50 ohms and a minimum power rating of 1200W.

The maximum allowable RF power input to the automatch unit is 3kW.

2.2.4 Electrical supply

The electrical supply required for the automatch unit are is 24VDC at 2A maximum.

2.2.5 Extraction

The extraction collar fitted on the top cover must be connected to an extraction system having a minimum flow rate of 1 m³/minute at 60 Pa extraction pressure.

This requirement can be waived for alumina tubes **provided those responsible for machine safety permit it**. They should perform a risk assessment which considers breaking of the ICP tube during processing.

The requirement cannot be waived for an ICP 180 fitted with a quartz tube, because UV emission from the plasma will generate ozone.

3. Description

3.1 Function

The **Plasmalab** ICP180 is an Inductively Coupled Plasma (ICP) source suitable for the **Plasmalab** System 100 or equivalent vacuum equipment. Its function is to create a highly ionized low pressure plasma above a substrate, without the need to couple RF power to the plasma capacitively through the substrate. The principal components of the source are shown in Fig 1.

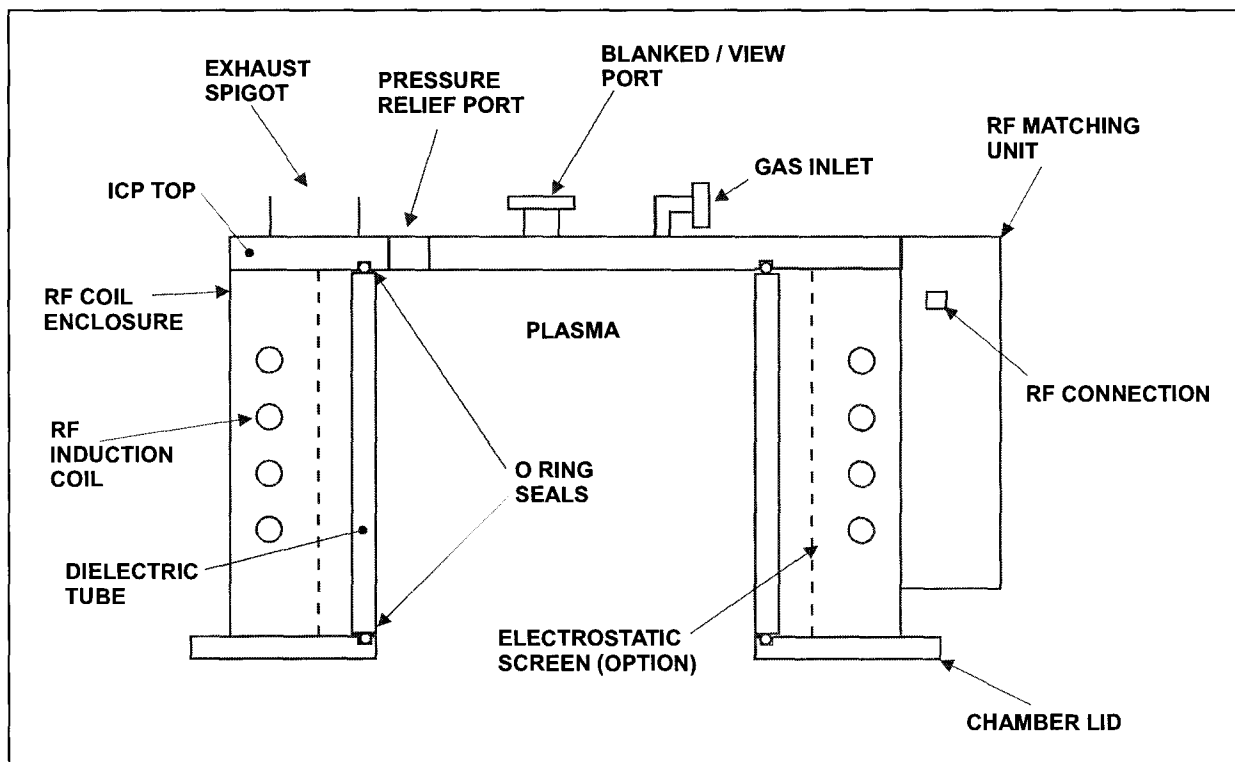

Fig 1: ICP 180 source - cross section of principal components

Plasma is created by electromagnetic induction when an alternating high frequency current in the RF induction coil causes a circulating current to flow in a low pressure plasma. The plasma can be initiated by the induction coil or by power applied to another system electrode, usually RF power to the substrate electrode.

To create a high circulating current in the RF coil in this non-resonant design without a high reflected power, an RF tuning network with automatic matching is mounted close to the coil. RF power at 13.56MHz at up to 3kW is supplied via the coaxial N-type 50 ohm connector on the matching unit. The matching unit contains motor-driven vacuum capacitors and a directional detection circuit, which acts to make the load impedance presented to the RF generator as close as possible to 50 ohms.

The metal ICP top, RF coil enclosure, and chamber lid, together with the matching unit covers and vacuum system underneath, form an enclosure to contain the strong electromagnetic radiation from the RF components.

WARNING

THE DIELECTRIC TUBE COULD FAIL CATASTROPHICALLY BY IMPLOSION WHEN UNDER VACUUM. IF IT IS NECESSARY TO OPEN THE RF ENCLOSURE FOR ANY REASON, VENT THE CHAMBER, OR WEAR APPROPRIATE PERSONAL PROTECTION.

WARNING

DO NOT OPERATE THE SOURCE WITHOUT THE COVERS PROPERLY ATTACHED. PARTS OF THE CIRCUIT OPERATE AT LETHAL VOLTAGES. RADIATION BURNS MAY OCCUR TO NEARBY PERSONNEL.

CAUTION

Nearby electrical equipment may experience RF interference if the source is operated without all covers and lids forming the RF enclosure properly secured.

Other components of the ICP180 include:

- A gas inlet connection, ¼ inch VCR female nut, feeding gas to distribution holes in the ICP top lid.
- A KF25 port, intended for laser interferometry.
- A 100mm diameter extraction collar.

WARNING

IF A QUARTZ ICP TUBE IS FITTED, ULTRA-VIOLET LIGHT FROM THE PLASMA CAN FORM OZONE IN THE AIR INSIDE THE RF ENCLOSURE. EXTRACTION SHOULD BE FITTED TO THIS PORT; EXTRACTION SHOULD BE FITTED IF THE GASES USED POSE A HAZARD TO PERSONNEL SHOULD THE ICP TUBE BREAK.

- An electrostatic screen. This minimises capacitive coupling between the RF induction coil and the plasma, which in turn reduces ion bombardment of the tube wall. It also eliminates cross-coupling between the ICP RF supply and any other RF generator on the same chamber, making phase-locking unnecessary. The electrostatic screen can be omitted if the ICP 180 is the only plasma source on the chamber.
- A pressure relief port. Should the system become pressurised, this will automatically open to prevent dangerous pressurisation of the ICP tube.

3.2 Mechanical assembly

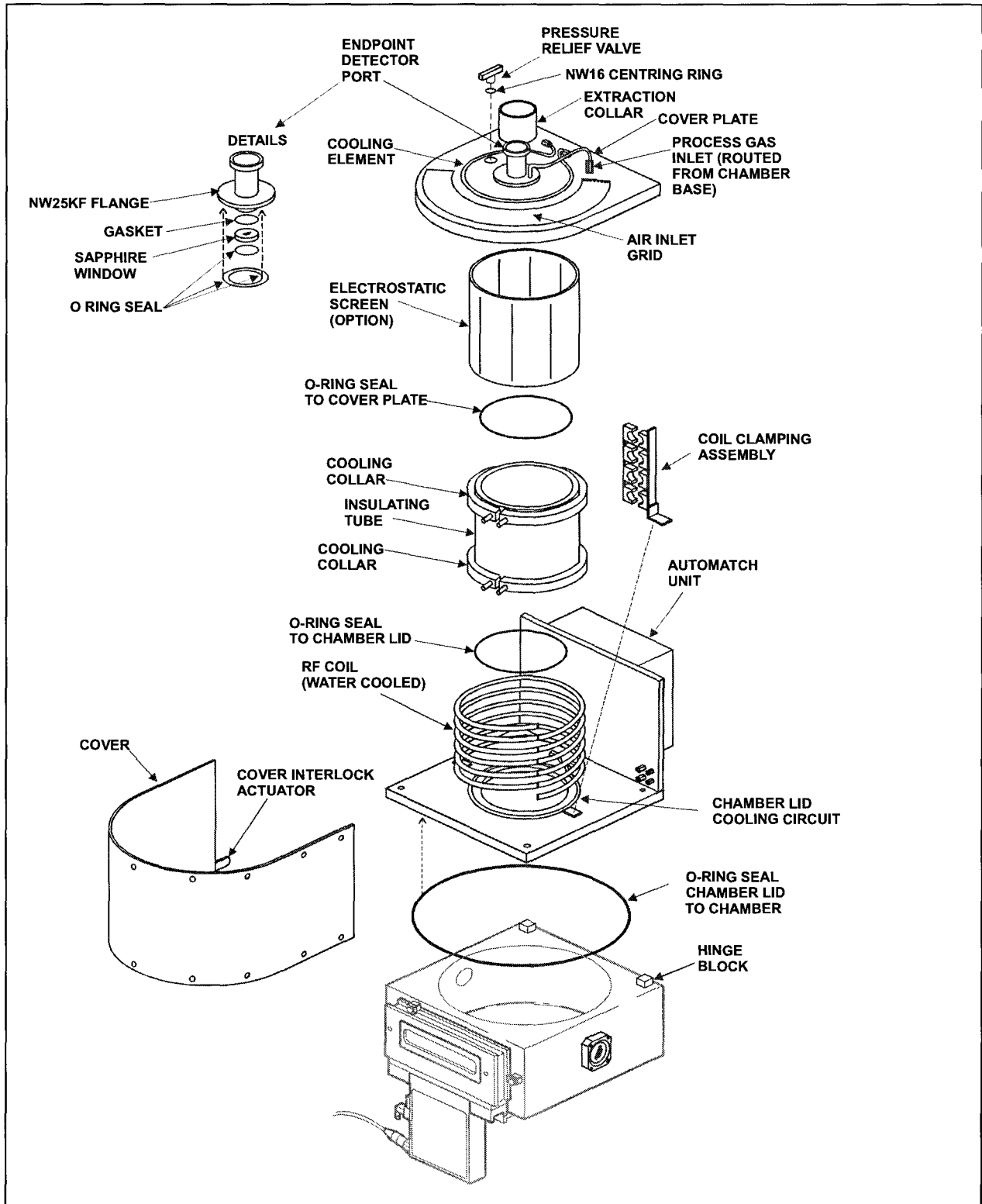

Fig 2: ICP 180 Exploded view

The **Plasmalab** ICP 180 is an assembly which can be fitted to a **Plasmalab** System 100 chamber in place of the standard chamber lid. The assembly comprises a chamber lid on which is mounted the ICP discharge chamber, an automatch unit and a shielding cover.

The chamber lid is secured to the process chamber by hinges which allow it to be tilted for process chamber maintenance. The lid is water cooled by a circular cooling element. Vacuum sealing between the lid and the process chamber is provided by an O-ring. A mounting plate attached to the lid supports the automatch unit.

The discharge chamber comprises an insulated tube sealed at its top and bottom by O-rings. The insulated tube is cooled at its top and bottom by cooling collars. An electrostatic shield surrounds the insulated tube. A water-cooled RF induction coil, supported by two clamping assemblies, is located outside of the insulated tube and electrostatic shield.

The top of the discharge chamber is a cover plate which incorporates an extraction cover, endpoint detector port, process gas inlet, pressure relief valve and a circular cooling element. Air is drawn into the space outside of the discharge chamber through a cooling grid.

The ICP 180 cover incorporates an interlock actuator (see Fig 2) which, when the cover is fitted, actuates a micro-switch located under the AMU. When the micro-switch is actuated, the contactor which supplies the source's RF Generator, is enabled. When the cover is not fitted, the RF Generator's supply is disabled.

3.3 Source specification

Description:	Inductively coupled plasma source for use with the Plasmalab System 100 .
RF:	Minimum generator capacity 1200W Maximum RF power handling 3000W Frequency: 13.56MHz.
Ion current density:	>1mA/cm ² at normal substrate position in the Plasmalab System 100, using Argon at 1 Pa.
Pressure range:	0.5Pa to 10Pa (3 to 70 mTorr). (Argon) Operation to 1mTorr is possible using >2KW RF.
Vacuum:	All joints < 5 x 10 ⁻⁸ mbar litre/sec leak rate on Helium leak test.

3.4 Graphs of typical operating characteristics

High ion flux to the wafer

A figure of merit for the ICP is the ion current density at the wafer, without RF applied to the wafer. This was measured by using the wafer table as an ion collection electrode, biased to -30 V dc. A good figure to achieve is 1 mA cm⁻²; much less than this means the source is not effective; much higher currents are not useful because the sample is heated too much.

The graph (see Fig 3) shows a nearly linear increase of ion current density with ICP power. There is no sign of saturation behaviour (unlike ECR), so higher powers could be used to get higher ion fluxes if required. The ICP 180 can handle up to 3 kW of RF power.

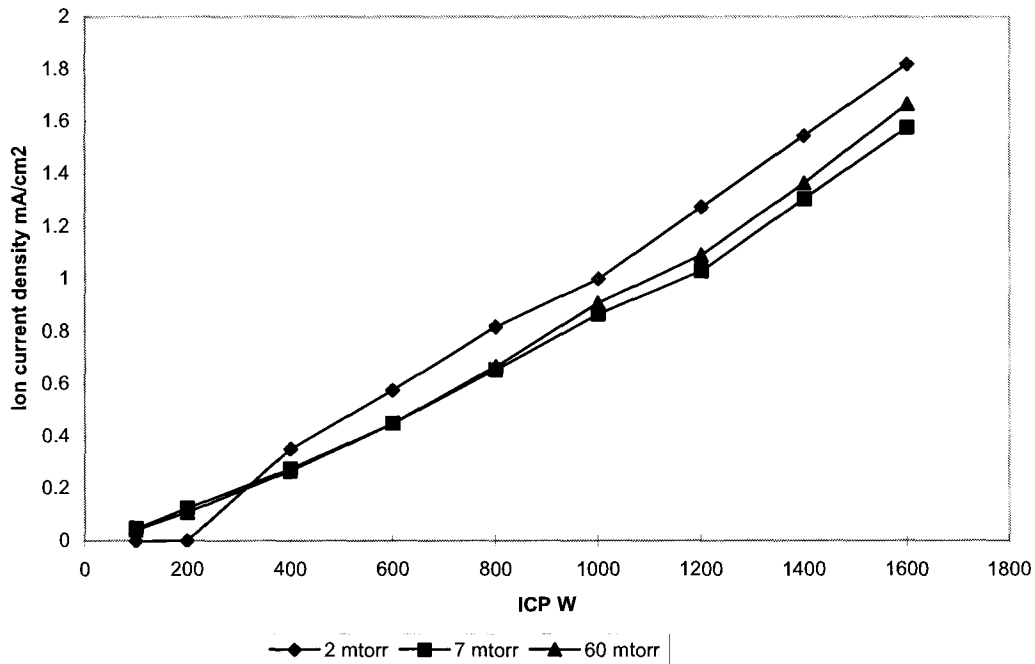

Fig 3: Ion current density at the wafer versus ICP power

Operating window

The operating window of the ICP 180 source in nitrogen is shown in Fig 4.

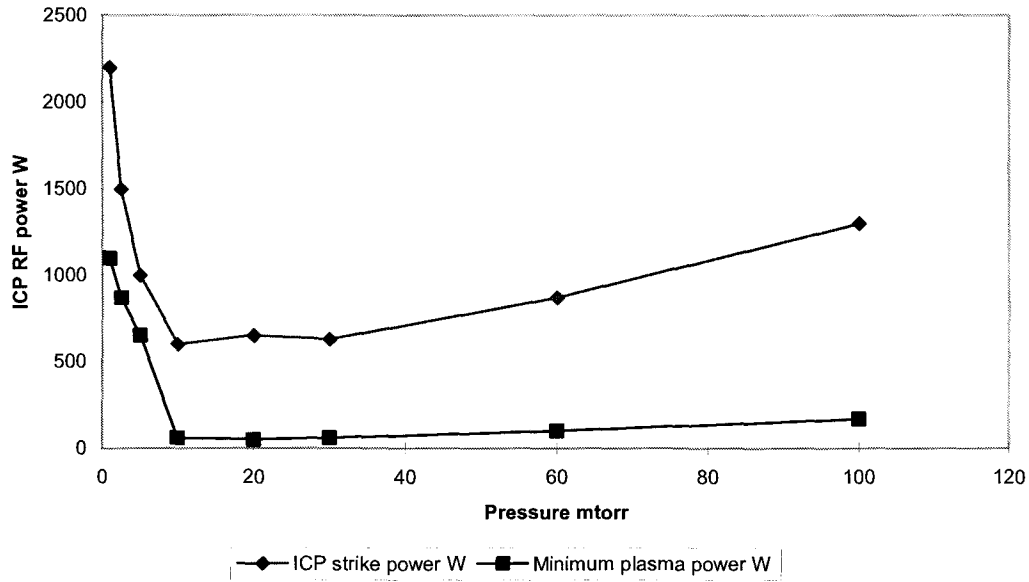



Fig 4: Operating window

4. Installation

This section applies if the **Plasmalab** ICP180 source is supplied as an upgrade, or as an exchangeable plasma source.

The ICP180 is installed as the entire top lid to a **Plasmalab** System 100, with a vacuum O ring on the underside of the ICP180 chamber lid. The chamber lid is secured by hinges which enable access to the process chamber interior for maintenance.

⚠ WARNING	PINCH POINT – WHEN THE CHAMBER LID IS OPENED OR CLOSED, LIMBS, FINGERS ETC CAN BECOME TRAPPED BETWEEN THE LID AND THE PROCESS CHAMBER BASE RESULTING IN SEVERE INJURY.
	<p>Ensure that all personnel are kept clear of the chamber lid when it is opened or closed.</p> <p>When opening or closing the chamber lid, ensure that both of your hands are kept clear of the pinch point.</p> <p>When the process chamber lid is to be kept in its raised position for prolonged periods, ensure that it is held safely in its open position without relying entirely on the gas support struts.</p>

After mechanical mounting, connect the services detailed in Section 2 of this manual.

The RF generator services should be connected according to the manufacturer's manual supplied with the generator.

5. Operating Instructions

5.1 Introduction

WARNING

BEFORE POWERING UP THE SOURCE, ENSURE THAT ALL COVERS AND SCREENS ARE FITTED CORRECTLY. DO NOT REMOVE THE COVERS OR SCREENS WHILST THE SOURCE IS UNDER VACUUM.

The only controls on the **Plasmalab** ICP 180 are the Automatch Unit (AMU) control switches, mounted on the system console.

5.1.1 Manual adjustment of the Automatch Unit

NOTE: The following text refers to systems fitted with an Automatch Unit manual adjustment panel. For systems having software control of the Automatch Unit, refer to Section 5 (Operating Instructions) of your system manual and the Automatch Unit's Equipment Manual.

A manual adjustment panel, shown in Fig 5, is located behind a flap in the front of the equipment rack. It comprises the following controls and indicators:

Auto / Manual switch: Sets the operating mode of the RF matching unit.

C1 MAX / MIN: Manual adjustment of RF matching capacitor C1. (Rotating its shaft clockwise or counter clockwise.)

C2 MAX / MIN: Manual adjustment of RF matching capacitor C2. (Rotating its shaft clockwise or counter clockwise.)

C1 PARK: Park position potentiometer for C1.

C2 PARK: Park position potentiometer for C2.

RF Interlock ON/OFF: Disables the RF interlock. RF generators deliver no power if the interlock is off.

Capacitor positions for C1 and C2 are displayed as numbers from 000 (minimum) to 999 (maximum).

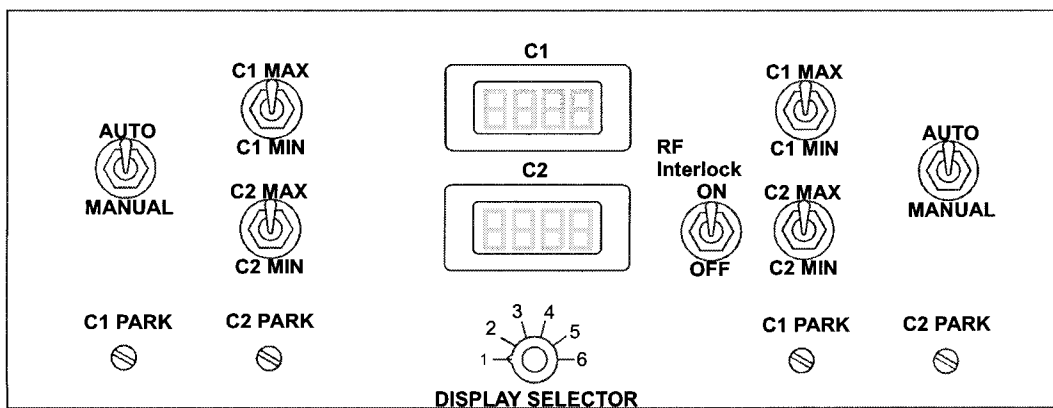

Fig 5: Typical AMU control panel

Note that Fig 5 shows an AMU control panel with control facilities for two AMUs. The left-hand side controls are for AMU1 and the right-hand side controls are for AMU2. The LCD displays are switched using the DISPLAY SELECTOR switch as shown in the following table.

DISPLAY SELECTOR POSITION	LCD 1 (UPPER)	LCD 2 (LOWER)
1	AMU 1 C1 POSITION	AMU 1 C2 POSITION
2	RF 1 FORWARD POWER	RF 1 REFLECTED POWER
3	RF 1 SETPOINT	RF 1 Hi/Lo
4	RF 2 FORWARD POWER	RF 2 REFLECTED POWER
5	RF 2 SETPOINT	SPARE
6	AMU 2 C1 POSITION	AMU 2 C2 POSITION

For full details of the Oxford Instruments Plasma Technology AMU, refer to its Operation and Maintenance manual in Volume 3 of this manual.

5.1.2 Obtaining a Plasma

- 1) Ensure that the **Plasmalab** System 100 (or other host system) has been powered up in accordance with its Operating Instructions.
- 2) Evacuate the plasma chamber. Flow process gas and set a pressure in the range 1 to 3 Pa (7 to 22 mTorr). Verify that adequate cooling water is flowing to the ICP180 source.
- 3) Turn on the RF power at 200W to 500W, then observe the reflected power.

WARNING

MONITOR THE RF RADIATION NEAR THE SOURCE WITH A SUITABLE METER. REFER TO APPENDIX A IN THE SYSTEM 100 MANUAL FOR DETAILS OF RF MEASUREMENTS.

If the reflected power is high (>50% of forward power):

- a) Check the Automatch Unit is powered up and switches set.
- b) Change to manual matching and search for a matching point; change both capacitors back to AUTO together: automatic matching should occur.

If the reflected power is >10% of the forward power, and the automatch is in automatic mode, skilled adjustment is needed. Refer to Section 6 (Maintenance) for guidance.

- 4) When the reflected power is low (<10% of forward power), gradually increase the RF power to 1500W. This is usually sufficient to strike a plasma. If a plasma does not strike apply any of the following strategies, as most appropriate to the application:
 - a) Change the gas mix away from electronegative gases (e.g. SF₆) towards gases which ionise more easily (e.g. Ar).
 - b) Turn on the ICP180 RF power at the same time as RF power to another electrode.
 - c) Check that the cooling flow rate is as specified, then gradually increase the RF power to a maximum of 3kW.

- d) Follow the procedure in Section 7 (Troubleshooting) for improving the quality of the match.
- e) Vary the pressure across the 1 to 5 Pa range.

It is usually possible to start the plasma directly at process conditions of interest. However, it is difficult to sustain a plasma at low RF power (<300W).

WARNING**BEFORE PROCEEDING WITH ANY MAINTENANCE WORK, READ SECTION 1 - HEALTH AND SAFETY.**

6. Maintenance

6.1 Maintenance schedule

The maintenance required to ensure continued safety and reliability is listed in the following Maintenance Schedule.

The periodicity is indicated by an asterisk (*****) in the appropriate column.

Task	As Required	Weekly	Three-Monthly	Notes
Measure RF emissions			*	See Appendix A of the System 100 manual for details. RF should also be measured after any maintenance involving the removal of covers and monitored continuously if the system is operated with RF power applied and any covers removed.
Inspect Quartz components			*	See sub-section 6.2.1. Periodicity may need to be reduced depending on process conditions.
Inspect Alumina components			*	See sub-section 6.2.1. Periodicity may need to be reduced depending on process conditions.
ICP dielectric tube cleaning	*			See sub-section 6.3.1. Periodicity depends on process condition.
Vacuum check		*		See sub-section 6.3.2.
Water cooling circuit			*	See sub-section 6.3.3.
RF enclosure exhaust flow			*	See sub-section 6.3.3.

6.2 Safety maintenance

Downstream microwave, ECR and induction coupled plasma sources contain quartz or alumina tubes or windows under vacuum, which may be subject to attack by the plasma process. If these components fail whilst under vacuum, an implosion can occur. This should not present a safety hazard, provided the equipment is used with all covers and screens in place, but may cause damage to system components.

Failure by implosion becomes more likely as the components age, therefore they should be regarded as consumable items. A programme of regular inspection and renewal of these components is necessary to minimise the risk of implosion.

WARNING**BEFORE PROCEEDING WITH ANY MAINTENANCE WORK, READ SECTION 1 - HEALTH AND SAFETY.****6.2.1 Inspection and renewal****WARNING****DISCARDED COMPONENTS MAY BE CONTAMINATED WITH RESIDUES FROM THE PLASMA PROCESS AND MAY BE ACIDIC OR TOXIC. DISPOSE WITH REGARD TO LOCAL PRACTICES.**

IMPORTANT: The following inspection intervals should be reduced if the source is operated for prolonged periods at high powers, especially for quartz components operating in fluorine-containing plasmas.

Quartz components

The internal surfaces of these components should be inspected at intervals of three months or less. Components showing significant signs of wear should be discarded and replaced by a new component. See 'Tube wall thickness' below.

Alumina components

The internal surfaces of these components should be inspected at intervals of six months or less. Components showing significant signs of wear should be discarded and replaced by a new component. See 'Tube wall thickness' below.

Tube wall thickness

The nominal minimum wall thickness of a new tube is 6 mm. During an inspection, if the wall thickness is reduced to 4 mm or less at any point then the tube must be replaced by a new component. To change the tube, refer to sub-section 6.4. page 19.

WARNING

BEFORE PROCEEDING WITH ANY MAINTENANCE WORK, READ SECTION 1 - HEALTH AND SAFETY.

6.3 Routine maintenance

<p>⚠ WARNING</p>	<p>PINCH POINT – WHEN THE CHAMBER LID IS OPENED OR CLOSED, LIMBS, FINGERS ETC CAN BECOME TRAPPED BETWEEN THE LID AND THE PROCESS CHAMBER BASE RESULTING IN SEVERE INJURY.</p>
	<p>Ensure that all personnel are kept clear of the chamber lid when it is opened or closed.</p> <p>When opening or closing the chamber lid, ensure that both of your hands are kept clear of the pinch point.</p> <p>When the process chamber lid is to be kept in its raised position for prolonged periods, ensure that it is held safely in its open position without relying entirely on the gas support struts.</p>

6.3.1 As required**ICP dielectric tube cleaning****WARNING**

IF VENTING AND OPENING THE ICP180 FULLY AFTER USING HALOGENATED GASES (CONTAINING CL- F- Br- OR I-), THE RESIDUAL GAS IN THE CHAMBER IS LIKELY TO EXCEED LONG TERM EXPOSURE LIMITS FOR THE EQUIVALENT ANHYDROUS ACID (HCl, HF, HBr, HI) IN GASEOUS FORM. RUNNING THE DEFAULT CLEANING RECIPE AND PUMPING FOR 30 MINUTES MORE WILL REDUCE THE RESIDUAL GAS CONSIDERABLY BUT USERS SHOULD MAKE THEIR OWN SAFETY ASSESSMENTS ON THE NEED FOR PERSONAL PROTECTIVE EQUIPMENT IN SUCH SITUATIONS.

Processes capable of generating hydrocarbon or fluorocarbon monomers can coat the inside of the ICP dielectric tube with polymer. An optimised cleaning process would need to be developed for each application, but as a default process use:

Gas: Oxygen (50-100 sccm).

Pressure: 2Pa (15 mTorr).

RF power: 1000W.

Time: 1 hour.

WARNING**BEFORE PROCEEDING WITH ANY MAINTENANCE WORK, READ SECTION 1 - HEALTH AND SAFETY.**

6.3.2 Weekly

Vacuum Check

Weekly, or as dictated by process constraints, perform a system vacuum check, recording:

- a) The base pressure after a standard pumping time.
- b) The rate of pressure rise in an isolated system.

Experience suggests that the O-ring seals at each end of the ICP dielectric tube are the most likely source of leaks in a new or freshly reassembled ICP180, but once sealed the source remains leak tight unless an O-ring seal fails. The design minimises exposure of the seals to the plasma, but tolerances in the tube construction (especially of quartz tubes) may mean the tube is not automatically concentric with the O-ring seals. This will reduce O-ring seal life, and require more care in assembly to obtain a good vacuum seal.

6.3.3 3-Monthly

Water cooling circuit

- 1) Turn off the RF supply, then vent the ICP180 source.
- 2) Open the RF enclosure and automatch, then inspect the fluid cooling path carefully for signs of leaks, blockage, corrosion, overheating or melting of plastic pipes.
- 3) Repair or replace any defective sections.
- 4) Pay attention to the layout of the cooling pipes: the design provides for minimum clearances between a water-cooled RF live component and the first point a plastic pipe rests against a grounded surface.
- 5) Ensure that the cooling flow rate is at least 2 litres/minute in the $\frac{3}{8}$ inch circuit and at least 1 litre/minute in the $\frac{1}{4}$ inch circuit.
- 6) Check the function of any water flow switches in the cooling path.

RF enclosure exhaust flow

- 1) Turn off the RF supply, then vent the ICP180 source.
- 2) Open the RF enclosure.
- 3) Remove any accumulations of dust or particles from the exhaust port and air inlet holes.
- 4) Wipe down the outside of the ICP dielectric tube and the RF coil to remove any material which may eventually lead to an RF arc.

RF emissions

- 1) Check that the RF emissions are within specification. See Appendix A in the **Plasmalab** System 100 manual for details.

WARNING**BEFORE PROCEEDING WITH ANY MAINTENANCE WORK, READ SECTION 1 - HEALTH AND SAFETY.**

6.4 Changing the ICP180 dielectric tube

This sub-section applies to ICP180 second series builds ('floating top' version) with the following part numbers:

100-6-54	ICP 180-FLOAT.TOP ASY(QUARTZ)
100-6-54/1	ICP180-FLOAT.TOP-ANOD.(QUARTZ)
100-6-55	ICP180-FL0.TOP ANG.VP(QUARTZ)
100-6-55/1	ICP180-FL.TOP-AN.VP-ANOD QU'TZ
100-6-56	ICP180 FLOAT TOP ASSY ALUMINA
100-6-56/1	ICP180 FLOAT TOP ASY ANOD ALUM
100-6-57	ICP180FLO.TOP ANG V/P(ALUMINA)
100-6-57/1	ICP180 FLO.TOP V/P ANOD ALUM.

Refer to assembly drawing MA00A23815

These instructions are given to assist personnel who are skilled in the maintenance of vacuum process equipment. The task includes operating the vacuum equipment and mechanical assembly. There is some lifting from the top of the equipment which may be easier with two persons.

Parts required:

MD00C18541 QUARTZ TUBE (ICP SOURCE)

Or

MD00C18542 ALUMINA TUBE (ICP SOURCE)

G/SEL/O-K/264 KALREZ O'RING BS 264 X2

G/GAS/FIT/614C ¼ INCH VCR GASKET X1

Safety

Risks associated with this procedure include:

- **Toxic gas.** Pump the system long enough to reduce residual toxic gases to an acceptable level. If halogen gases have been used in the chamber, run a plasma clean (1 hour 10 mTorr O2 50 sccm, 1000W ICP, 50 W bias or similar process) then pump for at least one hour. Follow local practice concerning risk assessment and personal protective equipment. OIPT practice is to use chemical filter masks when working on halogen process chambers.
- **Glass splinters.** Quartz tubes may have sharp edges. Damaged tubes may leave glass splinters. Take due care.
- **Implosion.** There is a small risk of catastrophic tube failure, especially the first time it is put under vacuum. Put the shielding in place before pumping the system. Always vent the system before removing the covers.
- **RF radiation.** The ICP180 coil is connected to a high power RF source which can cause burns or interfere with other equipment. Make sure the RF generator is switched off before removing any covers. After completing the following procedure, perform an RF leakage test as detailed in Appendix A of this system manual.

WARNING**BEFORE PROCEEDING WITH ANY MAINTENANCE WORK, READ SECTION 1 - HEALTH AND SAFETY.****Procedure**

- 1) Clean and pump the process chamber as recommended above
- 2) Vent the chamber
- 3) If an endpoint camera is fitted, remove the camera
- 4) Remove the outer cover of the ICP180
- 5) Disconnect the ¼ inch VCR joint feeding gas into the top of the ICP180
- 6) Free the water cooling tubes or turn off the water and disconnect the tubes to allow the ICP180 top vacuum lid to be removed
- 7) Undo the 6 bolts securing the top vacuum lid and remove the lid, exposing the dielectric tube
- 8) It will probably be necessary to open one or more of the inner RF shielding panels to gain access to the cooling clamps at the top and bottom of the ICP dielectric tube. Slacken the cooling clamps until it is possible to withdraw the old ICP tube.

Notes:

- a) The tube may stick to the lower vacuum O-ring.
- b) It should not be necessary to remove the electrostatic screen when changing the tube.

- 9) Clean the lower and upper O-ring seal areas thoroughly; take care to remove any sharp particles.
- 10) Inspect and if necessary replace the upper and lower O-ring seals
- 11) Inspect the new ICP tube for defects, especially chips or cracks at the vacuum sealing faces. Do not install a damaged tube.
- 12) Install the tube.
- 13) Tighten the cooling clamps. Do not use excessive force. The lower clamp should be firm, and the upper clamp should be much looser. This allows the electrostatic shield to move freely upwards by thermal expansion. The electrostatic screen must not be bowed out too much. Keep a clearance of at least 12 mm between the screen and the RF coil.
- 14) Reassemble the ICP 180 source
- 15) When the outer cover is in place, pump down and perform a leak check.
- 16) Perform an RF leakage test. See Appendix A of your Plasmalab system manual for details.
- 17) Dispose of the old tube in accordance with local regulations.

WARNING**BEFORE PROCEEDING WITH ANY MAINTENANCE WORK, READ SECTION 1 - HEALTH AND SAFETY.**

7. Troubleshooting

7.1 Customer Support Facilities

Oxford Instruments Plasma Technology has global Customer Support Facilities to provide a co-ordinated response to customer's queries. All queries are recorded on our Support Database and dealt with as quickly as possible. If we are not able to answer the query immediately, we will contact you as soon as possible.

Before contacting a Customer Support Facility, please ensure that you have referred to the appropriate section of your system manual, OEM manuals and electrical drawings.

Please direct all queries through your nearest support facility (see below) and have the following details available.

System Type, e.g. **PlasmalabSystem100** etc.

Works Order No. – This can be found on the front cover of your system manual.

Contact Information – Your name, Company and how we can contact you.

Details of your query – nature of the problem, part numbers of spares required, etc.

You can contact us via any of the following:

China**Beijing**

Tel: +86 106518 8160

Email: pt.support@oichina.cn**Shanghai**

Tel: +8621 6360 8530

Email: pt.support@oichina.cn**Germany**

Tel: +49 6122 937 161

Email: info@oxford.de**Japan**

Tel: +81 3 5245 3591

Email: oikkpt@oxinst.co.jp**Singapore**

Tel: +65 6337 6848

Email: pt.support@oxford-instruments.com.sg**Taiwan**

Tel: +886 3 5788696

Email: pt.support@oxford-instruments.com.tw**UK**

Customer Support Hotline: +44(0) 1934 837070

(0800 – 2000 UK local time)

Fax: +44(0) 1934 837071

Email: pt.support@oxinst.co.uk**USA**

Concord, MA

Tel: +1 978 9933 ext. 444

Toll Free: +1 800 447 4717 ext. 444

Fax: +1 978 369 8287

Email: support.pt@ma.oxinst.com

WARNING**BEFORE PROCEEDING WITH ANY MAINTENANCE WORK, READ SECTION 1 - HEALTH AND SAFETY.****WARNING****WHEN CARRYING OUT THE FOLLOWING PROCEDURES, CONTINUOUSLY MONITOR THE RF EMISSIONS AS DETAILED IN APPENDIX A. ON COMPLETION OF ALL TESTS, MEASURE THE RF EMISSIONS TO ENSURE THAT THEY ARE WITHIN SAFE LIMITS AS SPECIFIED IN APPENDIX A.**

7.2 High reflected power initial checks

NOTE: The following text refers to systems fitted with an Automatch Unit manual adjustment panel. For systems having software control of the Automatch Unit, refer to Section 5 (Operating Instructions) of your system manual and the Automatch Unit's Equipment Manual.

If the indicated reflected power shown on the RF generator during processing is greater than 10% of the indicated forward power it is necessary to carry out the following checks.

- 1) Check that the 24VDC supply to the automatch is present.
- 2) Check that the 24VDC fuse, located on the AMU main PCB, is OK.
- 3) If the capacitors have driven to their end stops or settled distant from a good match, set both AUTO/MANUAL switches to MANUAL.
- 4) Operate the C1 MIN/MAX switch until the indicated reflected power reduces.
- 5) Operate the C2 MIN/MAX switch to further reduce the indicated reflected power.
- 6) Continue to operate both MIN/MAX switches until the minimum indicated reflected power is obtained.
- 7) Set both AUTO/MANUAL switches to AUTO.

If it is not possible to obtain a reduction of indicated reflected power, check the mechanical drives to the capacitors as follows:

- 1) Switch off the RF power.
- 2) Remove the automatch covers.
- 3) Set both AUTO/MANUAL switches to MANUAL.
- 4) Use the MIN/MAX switches to drive each capacitor to both of its end stops (approximately 15 turns of spindle rotation between end stops). While the spindles are rotating, look for slipping of the capacitor shafts and for the mechanical coupling becoming disengaged. If required, re-engage the coupling and tighten the coupling screws. Verify that the electrical end stops limit capacitor adjustment within the mechanical alignment range. **CARE:** Approach the mechanical limits slowly, turning by hand. Driving hard past a mechanical limit can damage a capacitor.

NOTE: Capacitor spindle rotation clockwise decreases capacitance viewed from the drive motor side.

WARNING**BEFORE PROCEEDING WITH ANY MAINTENANCE WORK, READ SECTION 1 - HEALTH AND SAFETY.**

- 5) Refit the automatch covers.

7.3 High reflected power (system under vacuum)

- 1) Evacuate the process chamber. Set up a flow of gas to give a pressure in the range 1Pa to 3 Pa (7 mTorr to 22 mTorr).
- 2) Set the ICP 180 RF forward power to 100W. Check the reflected power. Depending on the reflected power reading, proceed as follows:
 - a) If the reflected RF power is < 2% of the forward RF power, the automatch is tuned correctly and ready for processing.
 - b) If the reflected RF power is > 5% of the forward RF power, carry out the procedure in sub-section 7.3.1.
 - c) If the reflected RF power is greater than 2% and less than 5% of the forward RF power, carry out the procedure in sub-section 7.3.2.

7.3.1 Automatch gives reflected power > 5%

WARNING**THE FOLLOWING PROCEDURE INVOLVES WORKING CLOSE TO EXPOSED LIVE RF CONDUCTORS AND MUST ONLY BE CARRIED OUT BY SKILLED PERSONNEL WHO ARE FULLY TRAINED AND AWARE OF THE POTENTIAL HAZARDS.**

NOTE: The following text refers to systems fitted with an Automatch Unit manual adjustment panel. For systems having software control of the Automatch Unit, refer to Section 5 (Operating Instructions) of your system manual and the Automatch Unit's Equipment Manual.

- 1) Turn off the RF supply.
- 2) Open the automatch cover to reveal the automatch PCB (see Fig 6).
- 3) Turn on the ICP 180 RF supply at 50W, monitor the RF power level in the working area continuously.
- 4) Set both Auto/Manual switches to MANUAL. Operate both MIN/MAX switches to obtain the lowest possible reflected power.
- 5) Refer to Fig 6 (page 25). Measure the DC voltages On the 'Automatch PCB', test point TP10 and TP110. These are monitoring points for the error signals which drive the variable capacitors. (0 to10V range). Adjust the potentiometers RV1 and RV2 iteratively until both voltages are as close as possible to zero volts.
- 6) Set both Auto/Manual switches to AUTO; the reflected power should remain low.
- 7) Replace the RF covers. Increase the ICP 180 RF power to 500W. If the reflected power rises above 50W, carry out the procedure in sub-section 7.3.2.

WARNING**BEFORE PROCEEDING WITH ANY MAINTENANCE WORK, READ SECTION 1 - HEALTH AND SAFETY.****7.3.2 Automatch gives reflected power of 2% to 5%**

- 1) Ensure that the automatch covers are securely fitted and that both Auto/Manual switches are set to AUTO.
- 2) Switch on the ICP RF supply, then set the forward power to 500W.
- 3) Observe the reflected power. Adjust error signal potentiometer RV1 by about one turn each way. The capacitors will adjust automatically in response: find the lowest reflected power point.
- 4) Adjust error signal potentiometer RV2 by about one turn each way. The capacitors will adjust automatically in response: find the lowest reflected power point.
- 5) Repeat Steps 3) and 4) until the best match is obtained; <2% reflected power should be possible.
- 6) Increase the RF power to 1000W and if required, repeat Steps 3) to 5).
- 7) **SAFETY** Always measure the RF radiation during and after adjustments to the automatch.

WARNING

BEFORE PROCEEDING WITH ANY MAINTENANCE WORK, READ SECTION 1 - HEALTH AND SAFETY.

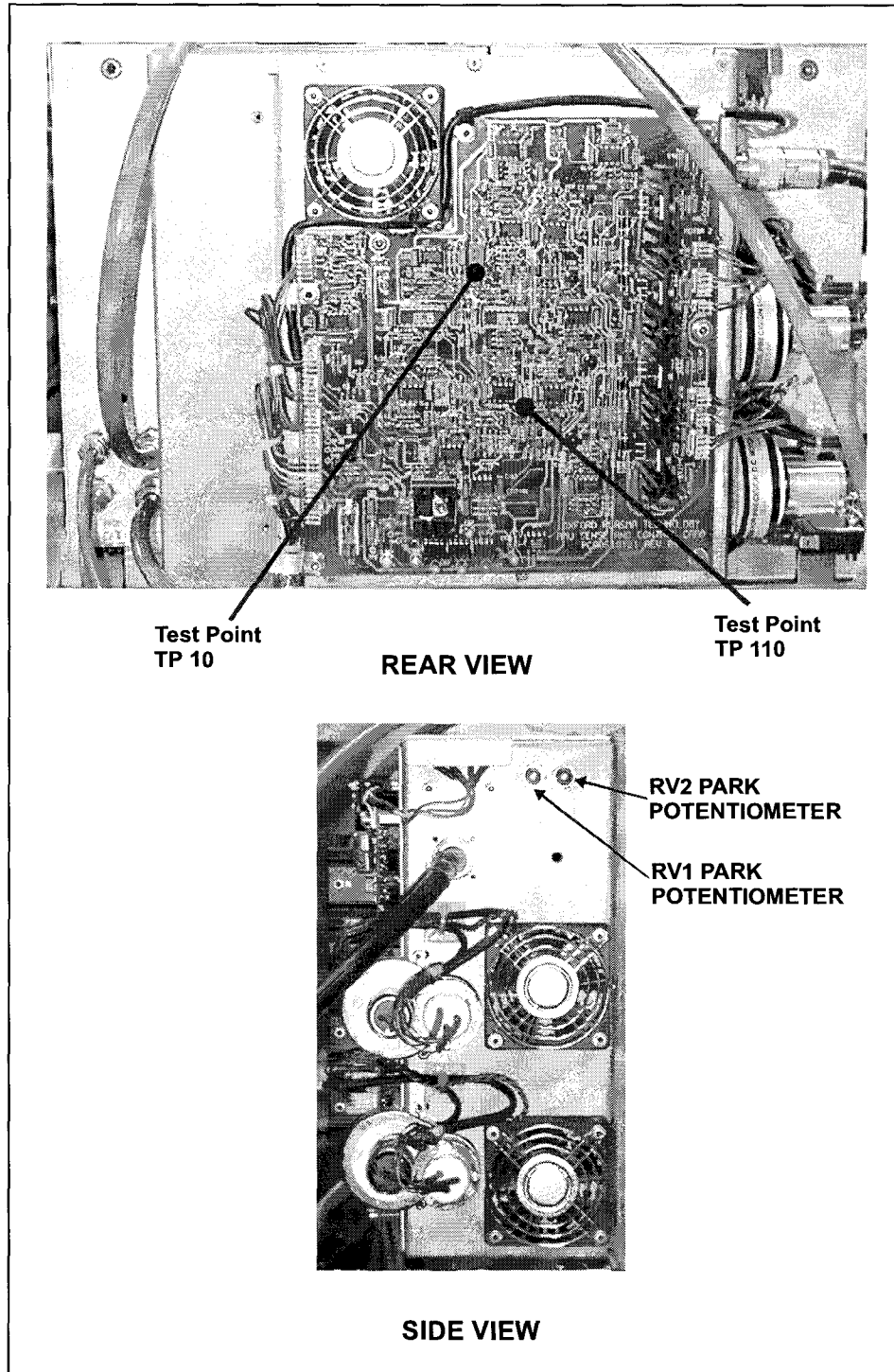

Fig 6: Automatch components

OIPT locations worldwide

UK

Oxford Instruments Plasma Technology
North End, Yatton,
Bristol, BS49 4AP
Tel: +44(0)1934 837000
Fax: +44(0)1934 837001
Email: plasma.technology@oxinst.co.uk
Web: www.oxford-instruments.com/plmchp5.htm

USA

Oxford Instruments Inc.
130A Baker Avenue Extension
Concord, MA 01742
Tel: +1 978 369 9933
Toll Free +1 800-447-4717
Fax: +1 978 369 8287
Email: info@ma.oxinst.com

Germany

Oxford Instruments GmbH
Otto-von-Guericke Ring 10,
D-65205 Wiesbaden
Tel: +49(0)6122 937161
Fax: +49(0)6122 937175
Email: plasma@oxford.de

Japan

Oxford Instruments K.K.
2-11-6 Tomioka
Koto-ku, Tokyo 135-0047
Tel: +81-3-5245-3261
Fax: +81-3-5245-4466
Email: oikkpt@oxinst.co.jp
Web: www.oxford-instruments.jp

People's Republic of China (Beijing)

Oxford Instruments China
Room 714, Office Tower 3,
Henderson Center,
No. 18 Jianguomennei Ave,
Dongcheng District,
Beijing 100005
Tel: +86 106518 8160/1/2
Fax: +86 106518 8155
Email: ptsales@oichina.cn
Web: www.oxford-instruments.com.cn

People's Republic of China (Shanghai)

Oxford Instruments China
Room 14-F, No.1 Plaza
800 Nanjing East Road
Shanghai 200001
Tel: +86 216360 8530
Fax: +86 216360 8535
Email: ptsales@oichina.cn
Web: www.oxford-instruments.com.cn

Singapore

Oxford Instruments Pte. Ltd
371 Beach Road,
#02-07 Keypoint
Singapore 199597
Tel: +65 6337 6848
Fax: +65 6337 6286
Email: oipt.sales@oxford-instruments.com.sg

Taiwan

Oxford Instruments Overseas
Marketing Ltd.
1F, No 23 Jing-Shang 19th Street,
Hsinchu, Taiwan
Tel: +65 6337 6848
Fax: +65 6337 6286
Email: oipt.sales@oxford-instruments.com.sg

OXFORD INSTRUMENTS

All OIPT Systems

RF Automatic Matching Unit

Contents

1. Health and Safety	3
2. Description	3
2.1 Introduction.....	3
2.2 Major components	4
2.2.1 Automatch control panel.....	4
2.3 Matching component layouts.....	5
2.4 Sense and control PCB.....	7
3. Test and setting up	8
3.1 Overview	8
3.2 Procedure	9
4. Operator adjustment	13
4.1 DC bias / Peak-to-peak switch setting	13
5. Operation	13
6. Troubleshooting	15
6.1 Fault diagnosis chart	15
6.1.1 Amplifier gain adjustment.....	16
6.1.2 Drive motor shaft to capacitor spindle alignment	17
6.2 Link Settings.....	18
6.3 Changing the RF components	19
6.4 Adjustment of capacitor park positions.....	20
7. OIPT locations worldwide	20
Fig 1: The Oxford Instruments Plasma Technology automatch unit.....	3
Fig 2: Typical AMU control panel	4
Fig 3: Matching component layouts.....	6
Fig 4: Sense and control PCB layout	7
Fig 5: Capacitor shafts rotation direction	10
Fig 6: Component locations	11
Fig 7: LK102 and LK2 settings	16

1. Health and Safety

For Health and Safety aspects of operating and maintaining the Oxford Instruments Plasma Technology Automatch Unit, refer to Section 1 - Health and Safety of your **Plasmalab** or **Ionfab** system manual.

2. Description

2.1 Introduction

The purpose of the Oxford Instruments Plasma Technology Automatch Unit (AMU) is to match the impedance of **Plasmalab** process chambers and **Ionfab** RF ion sources to RF generators with an output impedance of 50 ohms, operating at 13.56 MHz.

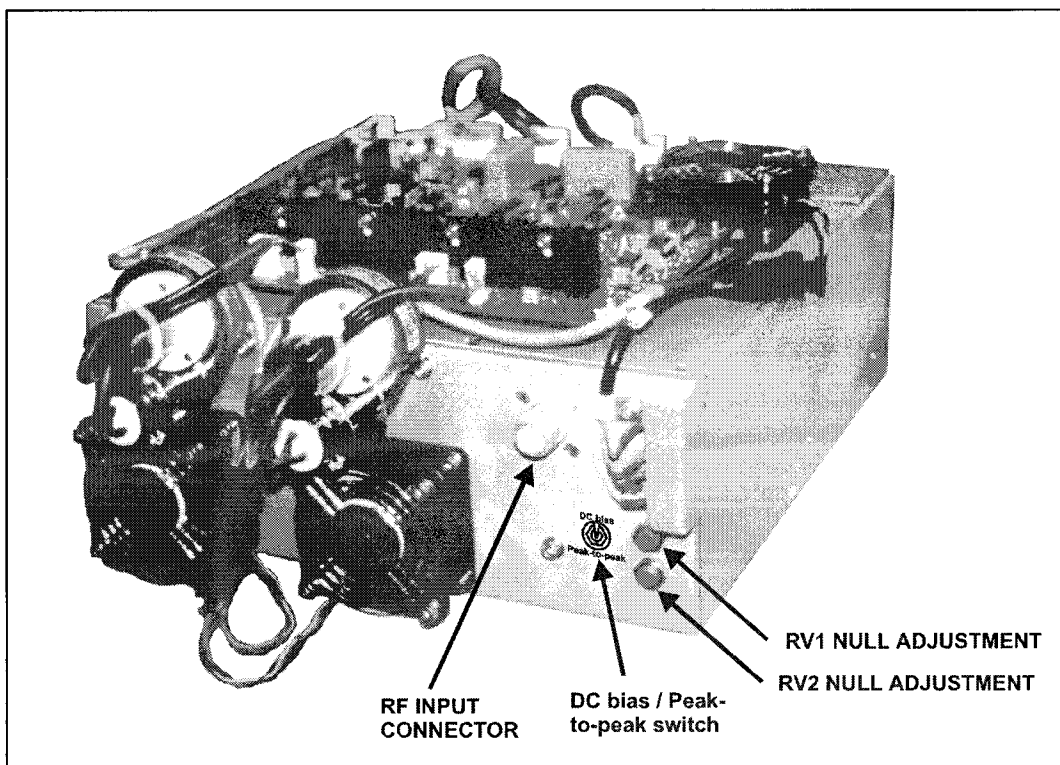

Fig 1: The Oxford Instruments Plasma Technology automatch unit

Different versions of internal components exist, but all AMUs in this series share common electronic controls and setting up instructions. The main versions are:

Low power: The two matching capacitors are air-cooled vane types.

High power: The two matching capacitors are water-cooled vacuum types.

The low power version is used for single wafer electrodes matching up to 500W. (The air vane AMU is rated for 300W operation in all OIPT tools, and for use up to 500W in specific builds.) The high power version is used in most other applications, including batch electrode matching, 3kW ICP source, and 3cm and 15cm RF ion sources.

Note that OIPT also manufactures a 5kW AMU for use with the ICP 380 source and the 35cm RF ion source. This AMU has an associated dedicated manual.

2.2 Major components

The AMU comprises:

- an input section with a type N coaxial connector, and a coupler giving 'out of match' error signals when the reflected power is greater than 1% of the forward power.
- an RF section containing two motor-driven variable capacitors, together with a coil where necessary.
- a DC bias / Peak to peak, set by local switch, signal path. (Only fitted to AMUs used for matching to a powered wafer table.)
- an electronic control board, which uses the error signals to drive the variable capacitors towards match.
- a manual drive panel with capacitor position readings, for manual adjustments.

2.2.1 Automatch control panel

A manual adjustment panel, shown in Fig 2 , is located behind a flap in the front of the equipment rack. It comprises:

- Auto / Manual switch: Sets the operating mode of the RF matching unit.
- C1 MAX / MIN: Manual adjustment of RF matching capacitor C1. (Rotating its shaft clockwise or counter clockwise.)
- C2 MAX / MIN: Manual adjustment of RF matching capacitor C2. (Rotating its shaft clockwise or counter clockwise.)
- C1 PARK: Park position potentiometer for C1.
- C2 PARK: Park position potentiometer for C2.
- RF Interlock ON/OFF: Disables the RF interlock. RF generators deliver no power if the interlock is off.

Capacitor positions for C1 and C2 are displayed as numbers from 000 (minimum) to 999 (maximum).

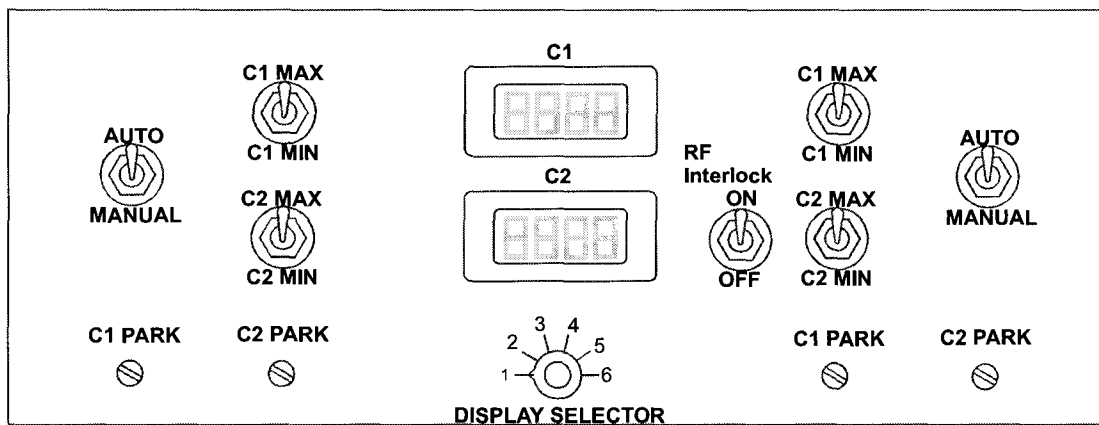

Fig 2: Typical AMU control panel

Note that shows an AMU control panel with control facilities for two AMUs. The left-hand side controls are for AMU1 and the right-hand side controls are for AMU2. The LCD displays are switched using the DISPLAY SELECTOR switch as shown in the following table.

DISPLAY SELECTOR POSITION	LCD 1 (UPPER)	LCD 2 (LOWER)
1	AMU 1 C1 POSITION	AMU 1 C2 POSITION
2	RF 1 FORWARD POWER	RF 1 REFLECTED POWER
3	RF 1 SETPOINT	RF 1 Hi/Lo
4	RF 2 FORWARD POWER	RF 2 REFLECTED POWER
5	RF 2 SETPOINT	SPARE
6	AMU 2 C1 POSITION	AMU 2 C2 POSITION

For a circuit diagram of the AMU control panel, refer to drawing 94-SE00C23249.

2.3 Matching component layouts

The layout of the matching components depends on the device to be matched to the RF Generator to ensure maximum power transfer. Typical layouts of the components are shown in Fig 3.

Note that in the typical layout, padding capacitors can be added in parallel with C1 and C2 to modify their capacitance ranges. Refer to sub-section 6.3 (page 19) for details.

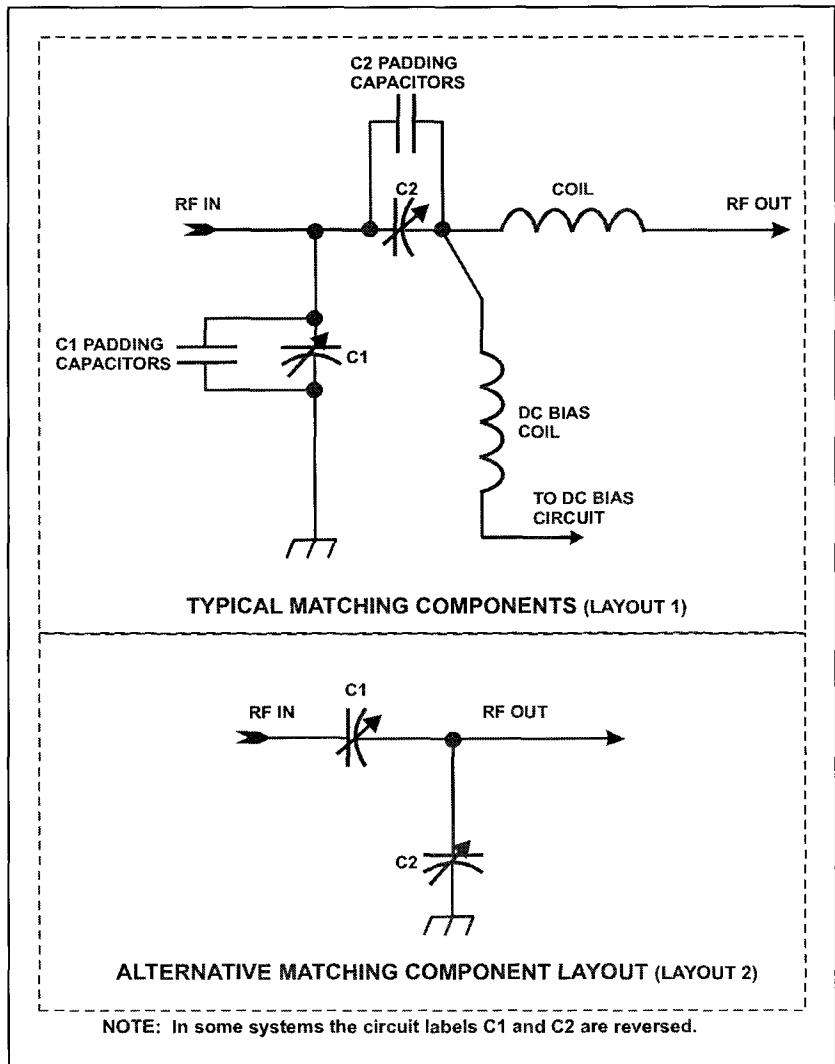

Fig 3: Matching component layouts

2.4 Sense and control PCB

Refer to drawing 94-SE00A17801 for a circuit diagram of the AMU. The layout of the Sense and Control PCB is shown in Fig 4 .

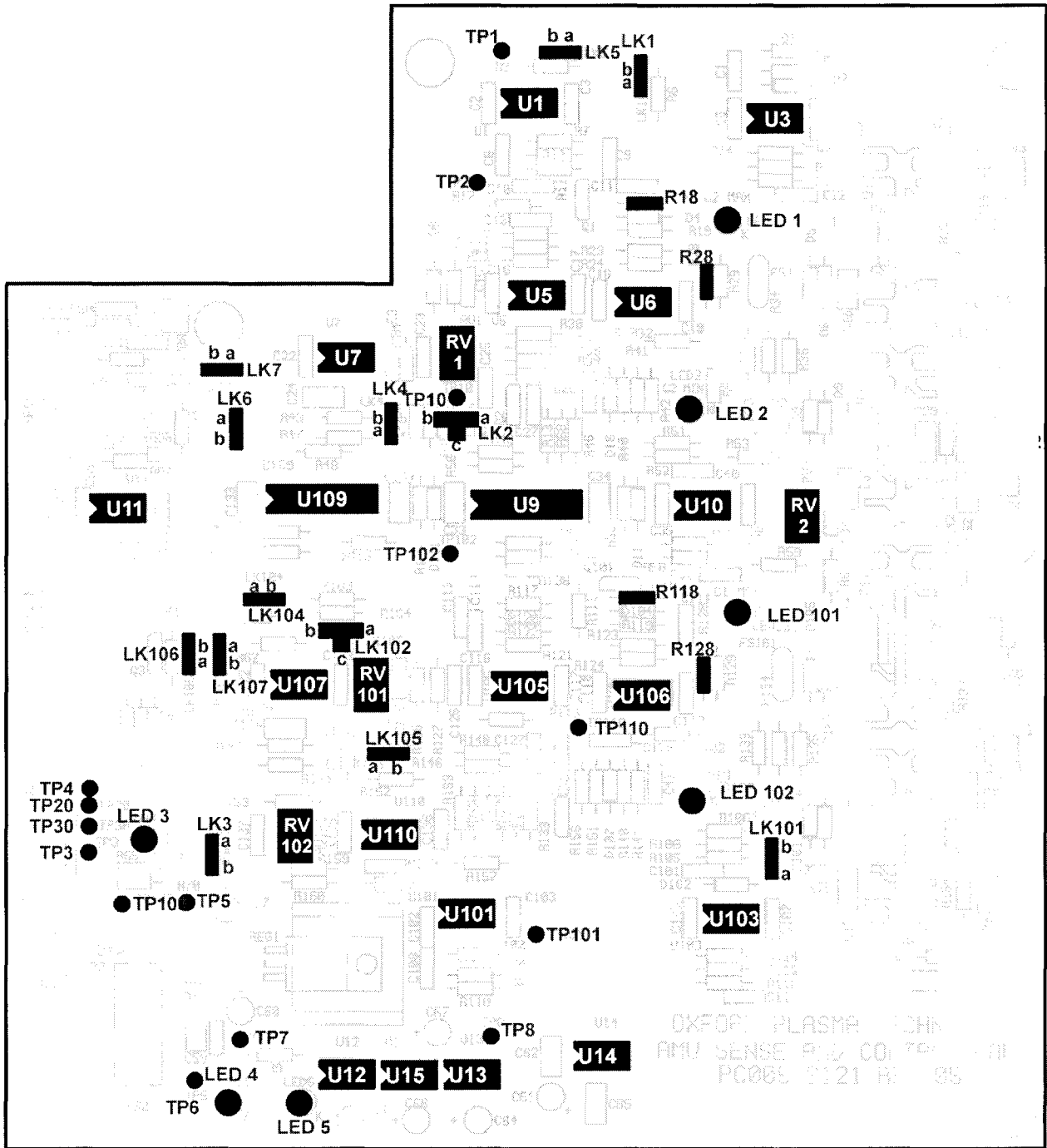

Fig 4: Sense and control PCB layout

3. Test and setting up



WARNING
HAZARDOUS RF VOLTAGE - CONTACT CAN CAUSE DEATH, SEVERE INJURY OR BURNS.

ANY WORK REQUIRING THE REMOVAL OF COVERS OR PANELS MUST ONLY BE PERFORMED BY AUTHORISED PERSONNEL WHO ARE AWARE OF THE HAZARDS INVOLVED.

NOTE: Detailed test instructions are contained in Oxford Instruments Plasma Technology Work Instruction No. 39. The following is a summary for the benefit of skilled service engineers. It should **not** be necessary for operators to perform these setting up operations.

3.1 Overview

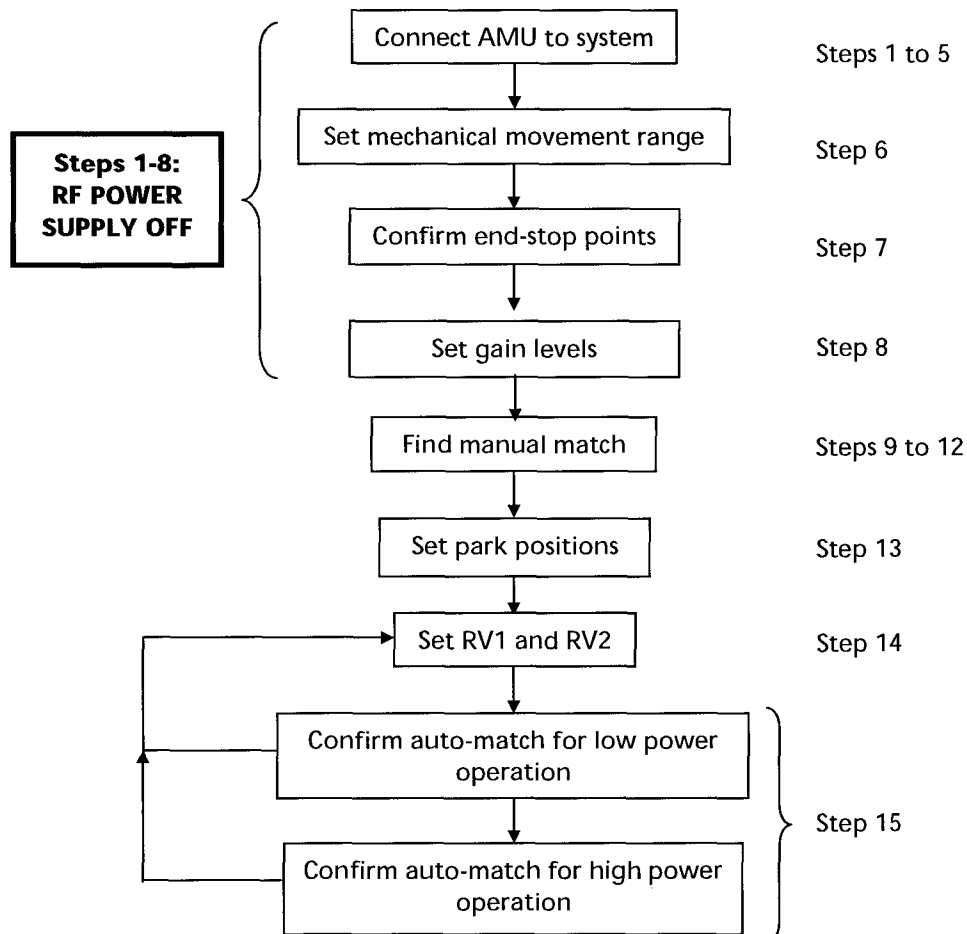

3.2 Procedure



WARNING
HAZARDOUS RF VOLTAGE - CONTACT CAN CAUSE DEATH, SEVERE INJURY
OR BURNS.

ENSURE THAT THE RF SUPPLY IS SWITCHED OFF WHILE CARRYING OUT
STEPS 1 TO 8.

- 1) Connect the AMU to the system. Make a good earth bond between the vacuum chamber and the AMU chassis.
- 2) Connect the output strap to the plasma electrode with at least a 25 mm wide copper strap, with at least 10 mm clearance between the live strap and any earthed part.
- 3) Confirm the polarity and voltage of the dc power source before connecting to the Sense and Control PCB:

JP7 pin 1	+24 Vdc
JP7 pin 2	0 V

- 4) Ensure the ventilation fans are all pulling air out of the automatch case and check the system cooling is turned on. For sense board cooling, check one fan is pulling air out and one is pulling air in to the sense board section.
- 5) Confirm the operation of each motor using the manual drive. An increase in capacitor position should make the vanes overlap more. In the case of a vacuum capacitor, an increase in position should turn the capacitor shaft anti-clockwise, when looking at it from the motor end (see Fig 5). Check with a capacitance meter in case of doubt.

If the motors do not turn in the correct direction check the plug in connector on the board, refer to OIPT Work Instruction No. 39.

- 6a) Calibrate the motors and their respective positions as follows:

For gear driven capacitors: Loosen screws retaining the motors to the AMU box, but don't remove completely and ensure the gears don't mesh.

For direct drive capacitors: Unscrew the motor plate attached to the side of the AMU box and pull the coupling apart.

Then,

For Air Vane Capacitor AMU:

Keeping gears separated, overlap the vanes fully. Then, making sure that the gears don't mesh, drive both motors to maximum (999), using the AMU control panel.

For Vacuum Capacitor AMU (AMU board REV05 and earlier):

Set the capacitor positions and drive motors to their required position according to the system type as shown in the following table:

System Type	Set C1 to	Then move in	Drive C1 Motor to	Set C2 to	Then Move in	Drive C2 Motor to
RIE/DP	Maximum	1 turn	Maximum (999)	Maximum	1 turn	Maximum (999)
ICP180	Maximum	1 turn	Maximum (999)	Minimum	1 turn	Minimum (000)
Ion Beam	Minimum	1 turn	Minimum (000)	Minimum	1 turn	Minimum (000)
ICP 380	Maximum	1 turn	Maximum (999)	Maximum	7 Turns	Maximum (999)

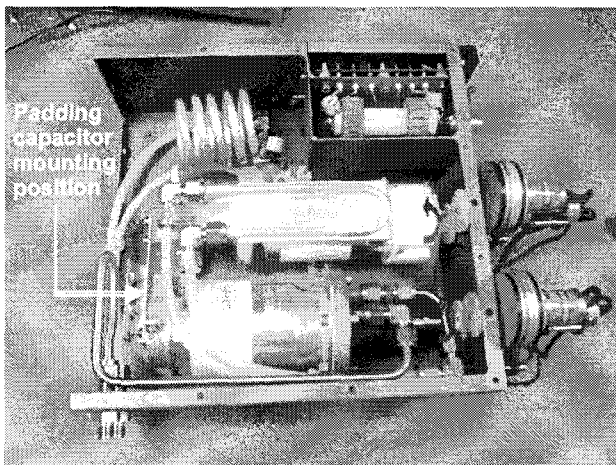

Fig 5: Capacitor shafts rotation direction

To find the minimum position, turn the capacitor shaft in the direction of the arrow, shown in Fig 5.

To find the maximum position, turn the capacitor shaft opposite to the direction of the arrow in Fig 5.

At the minimum position, the shaft becomes stiff; at the maximum position, the shaft becomes loose. **Do not try to turn the shaft past these points.** If when turning the capacitor to the maximum position, the shaft becomes loose, turn the shaft back in until it just begins to bite, this is the maximum position.

For Vacuum Capacitor AMU (AMU board with capacitor range mod.):

(Applies to all system types) Rotate the vacuum capacitor shaft clockwise as you look at it from the motor end (see Fig 5) until the shaft just becomes stiff, and then turn in half a turn. Making sure the motors don't mesh, drive both motors to minimum (000).

- 6b) **For gear driven capacitors:** Re-mesh the gears and tighten motor retaining screws, ensuring that the motor and capacitor positions don't move.

For direct drive capacitors: Loosen the coupling clamp screw on the capacitor side, turn the coupling on the capacitor side until it lines up with that on the motor side ensuring neither the capacitor nor the motor change position at any time. Clip the coupling together and tighten the clamp screw. Then re-attach the motor plate.

- 7) Confirm the 'end of range' stop functions using the manual drive switches located on the AMU panel:

Drive C1 positive to the stop position; LED 101 lights; stop point in the range 950-999

Drive C1 negative to the stop position; LED 102 lights; stop point in the range 000 - 050

Drive C2 positive to the stop position; LED 1 lights; stop point in the range 950-999

Drive C2 negative to the stop position; LED 2 lights; stop point in the range 000 - 050

If these aren't working as stated, refer to section 5 or OIPT Work Instruction No. 39

- 8) Set LK2 and LK 102 to position 'b', and then turn RV1 and RV101 fully clockwise until they begin to click (see Fig 6 or Fig 4).

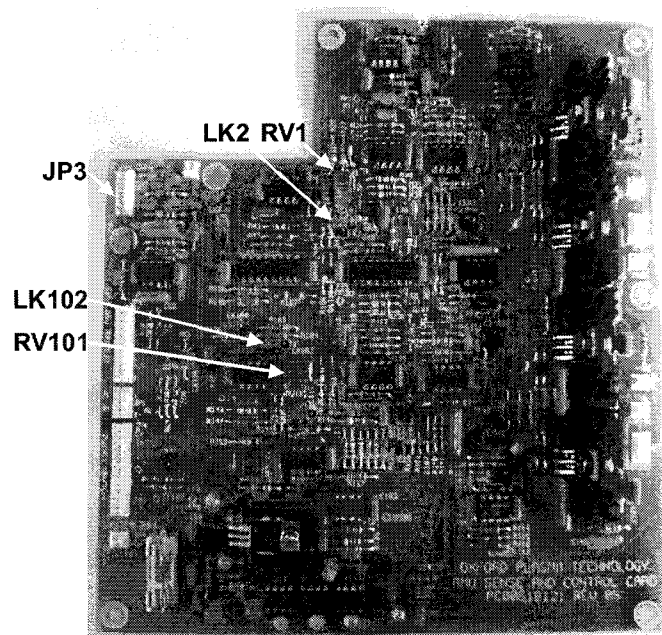

Fig 6: Component locations

- 9) Fit all covers to the AMU ensuring that they are securely fitted and connect the RF generator to the matching unit. Evacuate the process chamber and turn on a low power process.

For a Plasmalab system, a suitable process would be:

RF Generator output: 50 W
 Pressure: 50 mTorr (RIE), 1 Torr (PECVD), 0.1 Torr (PE)
 Gas: 20-100 sccm air, nitrogen or argon.

For an ion beam system, a suitable process would be:

RF generator output: 150 W (3 cm to 5 cm diameter)
 300 W (15 cm to 20 cm diameter)
 Gas: 10 sccm Argon

It may be necessary to use a gas burst to start the plasma, and it may be necessary to start the neutralizer, if fitted.

- 10) Manually match to the lowest possible reflected power using the AMU control panel, and make sure a plasma is running. Adjust the error signal zero potentiometers RV1 and RV2 (located on the same side of the AMU as the RF in connector; see Fig 1), while monitoring the two error signals on JP3 pins 1 and 3 (See Fig 6). These should be less than 20 mV when a match exists. Amplified error signals are accessible at TP 10 and TP 110; these should be made as low as possible when the RF is well matched.

For Vacuum Capacitor AMU (AMU board REV05 and earlier):

If it is not possible to find a match position due to the match position being beyond the range of the capacitors, stop the process and remove the AMU cover again. If C1 is attempting to drive above the maximum position, add 180 pF padding capacitor (Part Number 94-ECC1218), or turn 2 turns anti-clockwise towards maximum. If C1 is attempting to drive past the minimum position, remove a padding capacitor if already fitted, otherwise turn 2 turns clockwise towards minimum. If C2 attempts to drive above the maximum position turn 2 turns anti-clockwise, if C2 attempts to drive below the minimum position, turn 2 turns clockwise. Whilst doing this, be careful not to turn the capacitors beyond their physical end stops.

For Vacuum Capacitor AMU (AMU board with capacitor range mod.):

If C1 attempts to drive above maximum position, add 180 pF padding capacitor. If C1 is attempting to drive past the minimum position, remove a padding capacitor if already fitted. If C2 attempts to drive past maximum or minimum position, check that the correct inductor is fitted and that the capacitors are correctly fitted to the system. If these are correct, the match position is out of the range of C2.

For Air Vane Capacitor AMU:

If C1 or C2 attempts to drive above maximum position, add 180 pF padding capacitor. If C1 or C2 is attempting to drive past the minimum position, remove a padding capacitor if already fitted. It is not necessary to reset the positions of the Air Vane Capacitors.

- 11) Increase the RF power in a few steps to maximum and check for RF leakage, arcing or local overheating.
- 12) Rematch manually, when at maximum RF power, manually to less than 1% reflected power if possible; less than 3% is the maximum reflected power acceptable. Refine the zero settings of the error signals.
- 13) Make a note of the capacitor position values when a good match is achieved. Stop the process and adjust the park positions to a value below that of the match position (within around 050 units on the position display), making sure that C2 is closer to its match position than C1.

Re-start the process with the AMU controller in auto to make sure the match is successful. If there is a large reflected power, repeat Step 10. If there is a small amount of reflected power, which can't be reduced manually, RV1 and RV2 on the side of the AMU can be used to make finer adjustments when in auto mode.

- 14) If the capacitors oscillate when in auto, reduce the gain of the control circuit by slowly turning RV1 and RV101 anti-clockwise (if C2 oscillates adjust RV1, if C1 oscillates adjust RV101) until oscillations stop. If the potentiometer's RV1 or RV101 begin to click before the oscillations have ceased, turn them fully clockwise until they begin to click again and change LK2 (corresponding to RV1) or LK102

(corresponding to RV101) to position 'a' and begin turning the potentiometers anti-clockwise again until the oscillations stop.

- 15) Confirm the automatching behaviour, increasing the RF power to maximum in small steps, repeating Steps 10 to 13 if necessary.

4. Operator adjustment

WARNING

THE FOLLOWING ADJUSTMENT INVOLVES WORKING ON THE SYSTEM WITH PANELS/COVERS REMOVED. IT SHOULD ONLY BE CARRIED OUT BY TRAINED PERSONNEL WHO ARE AWARE OF THE HAZARDS INVOLVED.

4.1 DC bias / Peak-to-peak switch setting

The **DC bias / Peak-to-peak** switch is located on the outer case of the AMU, adjacent to RV1 (null adjustment potentiometer). See Fig 1, page 3.

This switch selects one of two sensing output signals from the AMU:

DC bias: This switch setting is the default position. The output is a **SCALED** dc voltage proportional to the RF-induced self-bias on the electrode, sometimes called the 'DC bias'. This is a negative offset voltage on the electrode with respect to ground, which is inverted and conventionally referred to as a positive value, typically 100 - 600 Vdc. Normal scaling can read up to 1000 Vdc. This signal is read by the front-end software with correct scaling on OIPT tools.

Peak-to-peak: The output is an **UNSCALED** dc voltage related to the peak-to-peak value of the RF signal at the output of the automatch. This can be useful when the scaled dc bias is inaccessible, for example if the electrode has no dc contact to the plasma because a quartz carrier plate masks the whole electrode. The value displayed on the PC screen will be an arbitrary value, not a true peak-to-peak value, but can still be a useful monitor.

Note that the software has no knowledge of the switch setting and is scaled only for the dc bias setting.

5. Operation

If the automatch has been set to 'auto', the unit will attempt to reduce the reflected RF power to minimum without the need for operator adjustments. It will normally reduce reflected power to less than 2% of forward power.

Use manual matching for the following:

- a) One or both capacitors has driven to a limit.
- b) To discover if a match exists within the range of the matching unit.

The adjustment panel for the automatch is located behind a hinged cover. Opening the cover reveals the following controls and indicators:

Auto/manual switch: In the 'Auto' position, the unit will attempt to tune for minimum reflected RF power. In the 'Manual' position, the capacitor positions are controlled manually.

C1 max/min switch: In manual mode, this switch can be used to drive capacitor C1 towards maximum or minimum.

C2 max/min switch: In manual mode, this switch can be used to drive capacitor C2 towards maximum or minimum.

Note that capacitor positions are displayed as a three-digit number from 000 (minimum) to 999 (maximum).

Display Selector Switch: The RF monitoring positions display the analogue voltages on the remote control lines to the RF generators, as a service aid. The Hi/Lo position reads a high (>9V) value when the wafer bias RF supply is at full scale, and a low (<1V) value when this supply is scaled back to one-tenth full power. This feature improves resolution of RF low power.

C1 park. Potentiometer: This control can be fitted either to the control panel or on the AMU control board. The automatch will drive C1 to this pre-set position when the RF is turned off, if the unit is set to 'auto'

C2 park. Potentiometer: This control can be fitted either to the control panel or on the AMU control board. The automatch will drive C2 to this pre-set position when the RF is turned off, if the unit is set to 'auto'

6. Troubleshooting



WARNING
HAZARDOUS RF VOLTAGE - CONTACT CAN CAUSE DEATH, SEVERE INJURY OR BURNS.

ANY WORK REQUIRING THE REMOVAL OF COVERS OR PANELS MUST ONLY BE PERFORMED BY AUTHORISED PERSONNEL WHO ARE AWARE OF THE HAZARDS INVOLVED.

6.1 Fault diagnosis chart

Use the following chart to locate and identify faults. Note that the chart lists typical fault symptoms and is not exhaustive.

SYMPTOM	POSSIBLE CAUSES	ACTION
(A) Drive motors do not respond to automatic or manual control	Fuse FS2 blown Fuse FS1 or FS101 tripped.	Investigate and repair fault, which caused the fuse to blow. Then renew the fuse. Investigate and repair the fault, which caused the fuse to trip. (The fuses will automatically reset once the fault is repaired.) Note that these components are semiconductor fuses which respond to an increase in current above their rating (approximately 200 mA) by increasing their internal resistance significantly. The voltage drop across each of these components under non-fault conditions is approximately 0.5V When tripped by high current, the voltage drop is almost the full supply voltage i.e. 24V. After power is removed, the devices require 20 seconds to cool down and reset.
(B) C1 or C2 drive to min or max	1. C1 or C2 starting too far from final match position 2. Match position is out of accessible range	Adjust park potentiometers (Refer to sub-section 6.4 (page 20)). 1. Change process conditions 2. Change component fit in AMU (skilled personnel only). Refer to sub-section 6.3 (page 19).
(C) C1 or C2 drive to min or max and do not return manually	Capacitor has travelled past an electrical limit	1. All vane capacitors only: Continue manual travel in the same direction (to max if capacitor is at max). The capacitor will turn fully until it passes the opposite limit. 2. Readjust limit settings
(D) Plasma does not strike even though the reflected power is low	Gas pressure is too low or too high	Caution: do not run for > 2 minutes in this condition. Change gas pressure to 20 - 200 mTorr range (RIE), or 0.5 - 1.5 Torr range (PECVD)

SYMPTOM	POSSIBLE CAUSES	ACTION
(E) C1 or C2 oscillate close to match	1. Amplifier gain too high 2. C1 or C2 spindle thread dirty.	See sub-section 6.1.1 (page 16). Remove capacitor, clean and re-lubricate capacitor's spindle thread and bearing. Re-align; see sub-section 6.1.2 (page 17).
(F) Drive motor shafts rotate but capacitor spindles do not.	Coupling between the motor shafts and capacitor spindles has become disengaged or loose.	See sub-section 6.1.2 (page 17).
(G) End stops don't work, motor drives through.	Park potentiometers have broken	Check park potentiometers behind AMU control panel and replace if necessary.
(H) Error signal pots don't adjust the error signal or both adjust one signal only.	Links placed incorrectly	Check links LK6, 7, 10 & 107 to ensure they are in the correct position. If link is open end type, ensure that metal insert is still present.

Hints and Tips

- Do not remove anything from the Motor Control board without removing the power (JP2) first.
- When in 'Auto' mode RV1 and RV2 found on the side of the AMU casing can be used to make fine adjustments to the match position.

6.1.1 Amplifier gain adjustment

Refer to Symptom (E) in the Fault diagnosis chart (see sub-section 6.1, page 15).

When adjusting the amplifier gain, initially adjust the associated variable resistor (RV101 for C1 or RV1 for C2; see for locations). These variable resistors provide a 'fine' adjustment. If required, a coarse adjustment is available by using links LK102 and LK2 as shown in Fig 7.

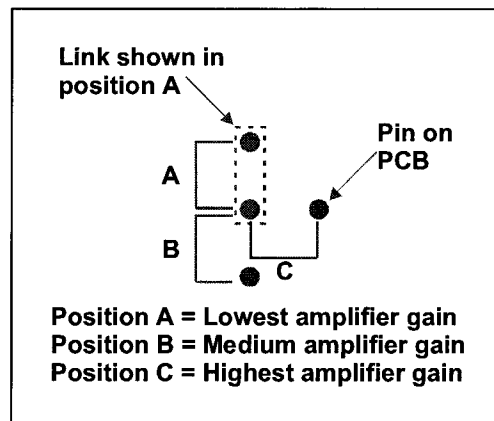

Fig 7: LK102 and LK2 settings

6.1.2 Drive motor shaft to capacitor spindle alignment

Refer to Symptom (F) in the Fault diagnosis chart (sub-section 6.1, page 15).

If the coupling between the motor shafts and capacitor spindles, has become disengaged or loose, use the following procedure to align the shafts/spindles to their correct relative positions.

- 1) Tighten the shaft and spindle grub screws.
- 2) Loosen the two bolts securing the motor/gear assembly to the AMU casing.
- 3) Carefully slide the motor/gear assembly away from the fan housing to disengage the gear wheels from the capacitor.
- 4) Align the gear wheels to the capacitor depending on the AMU version as follows:

a) Air spaced capacitor AMUs	(i) At the AMU control panel, set the relevant MANUAL/AUTO switch to MANUAL. (ii) Set the relevant MAX/MIN switch to MAX. (iii) Fully mesh the capacitor vanes.
b) Vacuum capacitor AMUs for RIE/PECVD applications	(i) At the AMU control panel, set the relevant MANUAL/AUTO switch to MANUAL. (ii) Set the relevant MAX/MIN switch to MAX. (iii) Set the relevant capacitor to maximum by rotating its shaft anti-clockwise until the shaft becomes loose and starts to unscrew from the capacitor body, then rotate the shaft one turn clockwise.
c) Vacuum capacitor AMUs for the ICP 180 application	For C1, use the procedure in b) above. For C2, use the following steps: (i) At the AMU control panel, set the C2 MANUAL/AUTO switch to MANUAL. (ii) Set the C2 MAX/MIN switch to MIN. (iii) Set C2 to minimum by rotating its shaft clockwise until the physical end stop is reached, and then rotate the shaft one turn anti-clockwise.
d) Vacuum capacitor AMUs for RF ion source applications	For C1 and C2 alignment in this AMU, use the procedure for C2 in c) above.

- 5) On completion of capacitor alignment in Step 4), re-engage the motor/gear assembly to the capacitor and tighten the securing bolts.
- 6) Check capacitor travel.

6.2 Link Settings

Incorrect link settings can cause the AMU to malfunction. The factory default settings are given in the following table:

Link	Air spaced Capacitor	Low Power Vacuum Capacitor	High Power Vacuum Capacitor	Notes
LK1	A	A	A	Setting A enables park position. Setting B disables park.
LK2	B	A	B	Coarse gain setting for C2 ('A' – low, 'B' – medium, 'c' - high)
LK3	A	A	A	Setting 'B' simulates RF on signal (for testing only).
LK4	B	A	A	Incremental Gain Signal. LK4 in position 'A' enables extra gain when in position control. This is used when driving a vacuum capacitor.
LK5	A	A	A	Panel/PLC Controller. Position B for AMU controlled by PLC
LK6	A	A	B	Changes the biasing on the input amplifier for C2 motor
LK7	B	B	A	Changes the biasing on the input amplifier for C2 motor
LK101	A	A	A	Setting 'A' enables park position. Setting 'B' disables park.
LK102	B	A	B	Coarse gain setting for C1 ('A' – low, 'B' – medium, 'C' - high)
LK104	B	A	A	Incremental Gain Signal. LK104 in position 'A' enables extra gain when in position control. This is used when driving a vacuum capacitor.
LK105	A	A	A	Panel/PLC Controller. Position 'B' for AMU controlled by PLC
LK106	A	A	B	Changes the biasing on the input amplifier for C1 motor
LK107	A	A	B	Changes the biasing on the input amplifier for C1 motor

6.3 Changing the RF components

This may be necessary to match a process beyond the normal operating range.



WARNING
HAZARDOUS RF VOLTAGE - CONTACT CAN CAUSE DEATH, SEVERE INJURY OR BURNS

Any work requiring the removal of covers or panels must only be performed by authorised personnel who are aware of the hazards involved.

Turn off the RF generator completely before removing the smaller L-section cover. This reveals the ends of the two variable capacitors and mounting positions for extra fixed capacitors.



CAUTION

Components fitted must be suitable for RF power service. Low power circuit devices will overheat quickly.

Suitable components are given in the following table:

OIPT Part Number	Capacitance	Rating
94-ECC1209	90pf	1kV
94-ECC1218	180pF	2kV

Change components according to the following table:

C1 going maximum	Add fixed capacitance in parallel with C1	See following NOTE .
C1 going minimum	Remove fixed capacitance in parallel with C1	Minimum is zero
C2 going maximum	<ol style="list-style-type: none"> Add fixed capacitance in parallel with C2 Increase coil inductance 	See following NOTE .
C2 going minimum	<ol style="list-style-type: none"> Remove fixed capacitance in parallel with C2 Decrease coil inductance 	Minimum is zero fixed capacitance
<p>NOTE: Variable capacitors C1 and C2 have a maximum capacitance of 1000pF and 500pF respectively. For each of these variable capacitors there are three positions for fitting parallel 'padding' capacitors. Therefore, a maximum of 3 x 180pF padding capacitors could be fitted but usually there is no need to fit more than one padding capacitor (i.e. 180pF).</p>		

6.4 Adjustment of capacitor park positions

The capacitors drive automatically to the park positions if:

the AMU is set to Auto

the RF is off

the circuit board links enable parking

The park positions can be adjusted when all of these conditions are satisfied, by altering the corresponding potentiometer with a small flat-bladed screwdriver. The capacitor will move when the potentiometer is adjusted, and the park position is displayed as the capacitor position.

7. OIPT locations worldwide

UK

Oxford Instruments Plasma Technology
North End, Yatton,
Bristol, BS49 4AP
Tel: +44(0)1934 837000
Fax: +44(0)1934 837001
Email: plasma.technology@oxinst.co.uk
Web: www.oxford-instruments.com/plmchp5.htm

USA

Oxford Instruments Inc.
130A Baker Avenue Extension
Concord, MA 01742
Tel: +1 978 369 9933
Toll Free +1 800-447-4717
Fax: +1 978 369 8287
Email: info@ma.oxinst.com

Germany

Oxford Instruments GmbH
Otto-von-Guericke Ring 10,
D-65205 Wiesbaden
Tel: +49(0)6122 937161
Fax: +49(0)6122 937175
Email: plasma@oxford.de

Japan

Oxford Instruments K.K.
2-11-6 Tomioka
Koto-ku, Tokyo 135-0047
Tel: +81-3-5245-3261
Fax: +81-3-5245-4466
Email: oikkpt@oxinst.co.jp
Web: www.oxford-instruments.jp

People's Republic of China (Beijing)

Oxford Instruments China
Room 714, Office Tower 3,
Henderson Center,
No. 18 Jianguomennei Ave,
Dongcheng District,
Beijing 100005
Tel: +86 106518 8160/1/2
Fax: +86 106518 8155
Email: ptsales@oichina.cn
Web: www.oxford-instruments.com.cn

People's Republic of China (Shanghai)

Oxford Instruments China
Room 14-F, No.1 Plaza
800 Nanjing East Road
Shanghai 200001
Tel: +86 216360 8530
Fax: +86 216360 8535
Email: ptsales@oichina.cn
Web: www.oxford-instruments.com.cn

Singapore

Oxford Instruments Pte. Ltd
371 Beach Road,
#02-07 Keypoint
Singapore 199597
Tel: +65 6337 6848
Fax: +65 6337 6286
Email: oipt.sales@oxford-instruments.com.sg

Taiwan

Oxford Instruments Overseas
Marketing Ltd.
1F, No 23 Jing-Shang 19th Street,
Hsinchu, Taiwan
Tel: +65 6337 6848
Fax: +65 6337 6286
Email: oipt.sales@oxford-instruments.com.sg

Plasmalab

Modular Cluster System - ICP 180

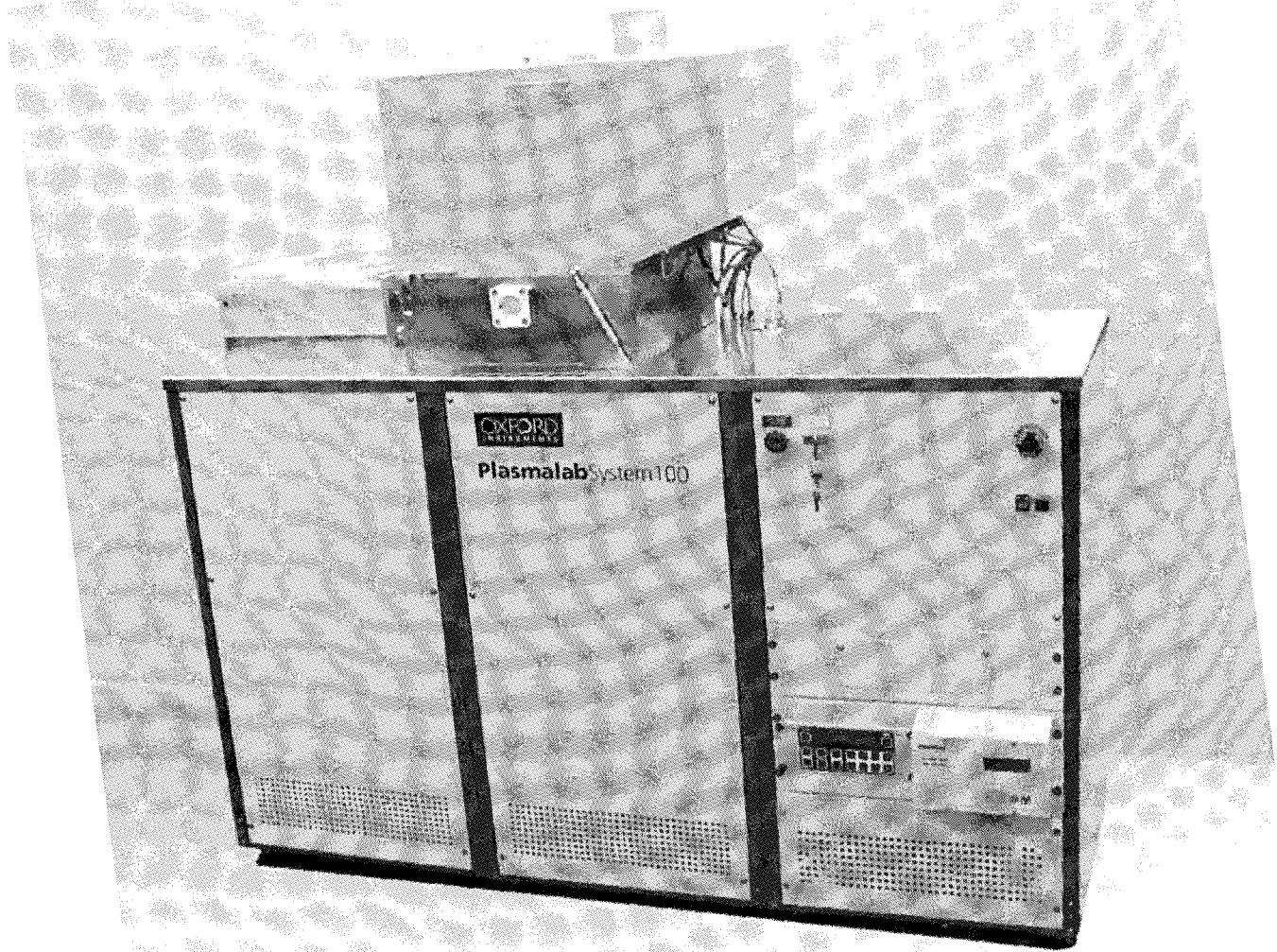

Issue 2: November 2002



Contents

Contents	ii
Introduction	iii
Location of major components	v
Section 0 System common components	0-1
<i>Section 1 Intentionally left blank</i>	
<i>Section 2 Intentionally left blank</i>	
Section 3 Process chambers	3-1
<i>Section 4 Intentionally left blank</i>	
Section 5 Lower electrode	5-1
Section 6 RF plasma generation, power supplies	6-1
Section 7 Vacuum measurement	7-1
Section 8 Pumping pipework	8-1
Section 9 Process gas handling	9-1
Section 10 Wafer handling options, load locks and robotics	10-1
Section 11 Spares	11-1
Section 12 Accessories	12-1

Introduction

This Illustrated Parts Catalogue has been prepared to enable the rapid identification of components of the Oxford Instruments Plasma Technology **Plasmalab** System 100 (ICP 180) machine.

The catalogue is not a comprehensive list of all machine components, for details of components not included, please contact Oxford Instruments Plasma Technology (OIPT).

Contact your local OIPT representative for prices; see the last page of this catalogue for addresses, phone/fax numbers and e-mail addresses.

Catalogue organisation

This catalogue is organised to mimic the OIPT Bill Of Materials and Price List numbering system for ease of component location. Each major system component is identified by a number of the form **AAA-BB-CC**:

AAA: 100 represents the **Plasmalab** System 100 product.

BB: System sections as follows (note that not all available numbers are used) :

- 0: Compulsory elements of the basic system, such as frame, power box, Programmable Logic Controllers etc.
- 1: Not applicable to the **Plasmalab** System 100
- 2: Not applicable to the **Plasmalab** System 100
- 3: Process chambers and their options.
- 4: Not applicable to the **Plasmalab** System 100
- 5: Lower electrode
- 6: Plasma generation, power supplies.
- 7: Vacuum measurement.
- 8: Pumping pipework.
- 9: Process gas lines
- 10: Wafer handling options, load locks and robotics
- 11: Spare series
- 12: Accessories, cover plates, chillers, end point detectors etc.

The sections in this catalogue are numbered to match these system sections. So for example, if you are looking for a process chamber component, you will find it in Section 3.

CC: Sub assembly numbering.

Using the Parts Lists

In this catalogue 'item number' refers to the reference number used on an illustration, 'part number' refers to the unique number used to identify the part in Oxford Instruments Plasma Technology'.

To identify a part:

- 1) Locate the appropriate section from the contents list.
- 2) Find the required component on the relevant illustration and note its item number (see note (d) below).
- 4) Refer to the associated parts list table and find the item number.
- 5) Note the OPT part number and description.
- 6) Telephone or fax the part number and description to your local OIPT sales office or representative who can quickly locate the part on the spares database. See the last page of this catalogue for OIPT locations world-wide.

NOTES:

- (a) Where possible, the item number used in the illustrations is the same as that quoted on the OIPT Bill of Materials for the assembly. However, in some cases this has not been possible as more than one assembly may be shown in an illustration.
- (b) Where an item number has more than one part associated with it in a parts list table, this indicates component options which may vary according to the configuration of the machine: identify the component from the actual machine before selecting the correct option.
- (c) Items listed without item numbers in the parts list tables are not shown in the illustrations, but their OIPT Part Numbers and descriptions are listed to enable identification.
- (d) Printed Circuit Boards (PCBs) illustrated within this catalogue are assembled boards which include all integrated circuits and other components. To ensure the correct assembled board is supplied, read the PC number stamped on the PCB. This will read PC100xxxxxx. Check this with the OIPT spares department or include the number with your order, making sure to include any revision number printed on the circuit board.

Location of major components

FRONT VIEW

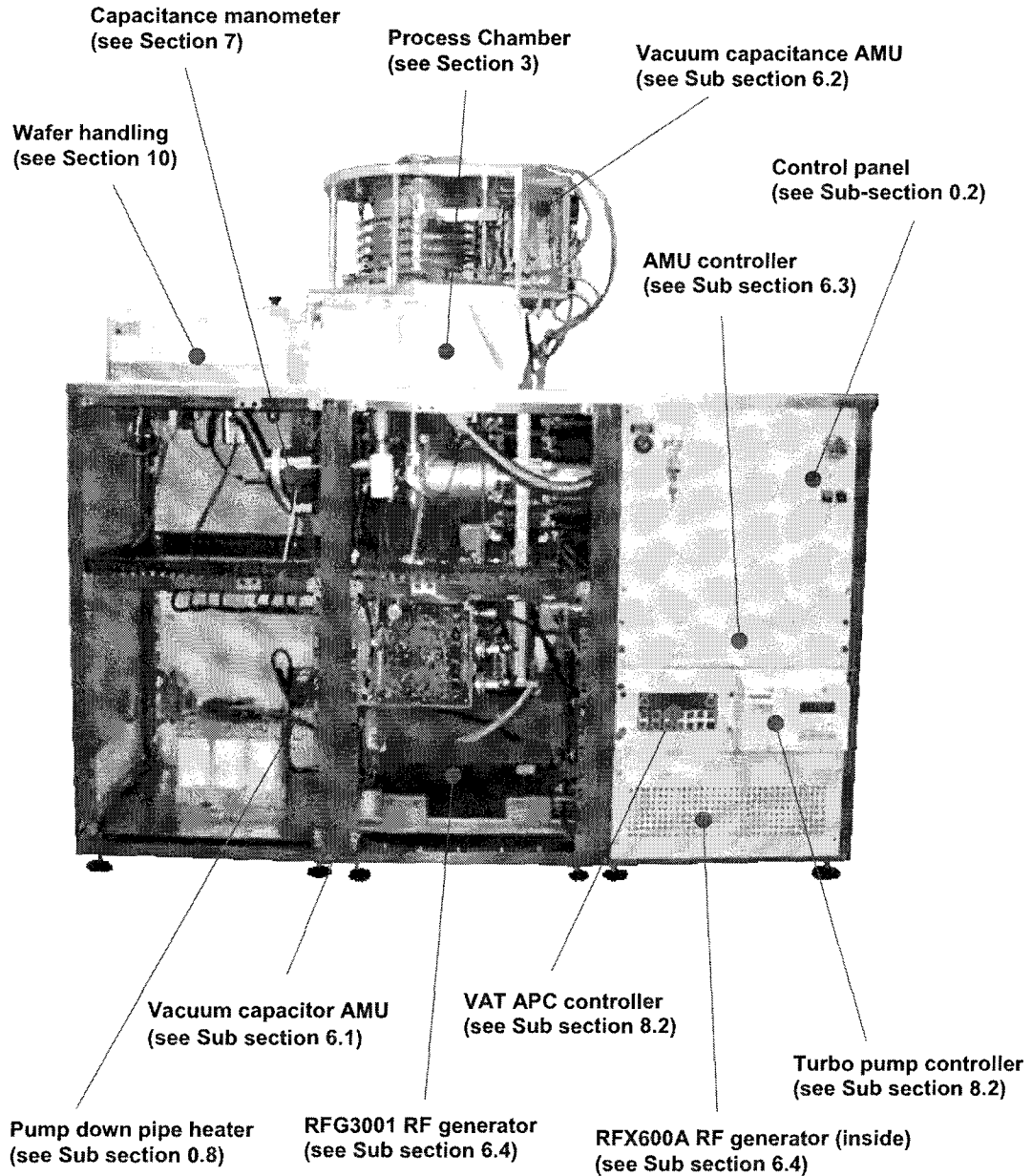

REAR VIEW

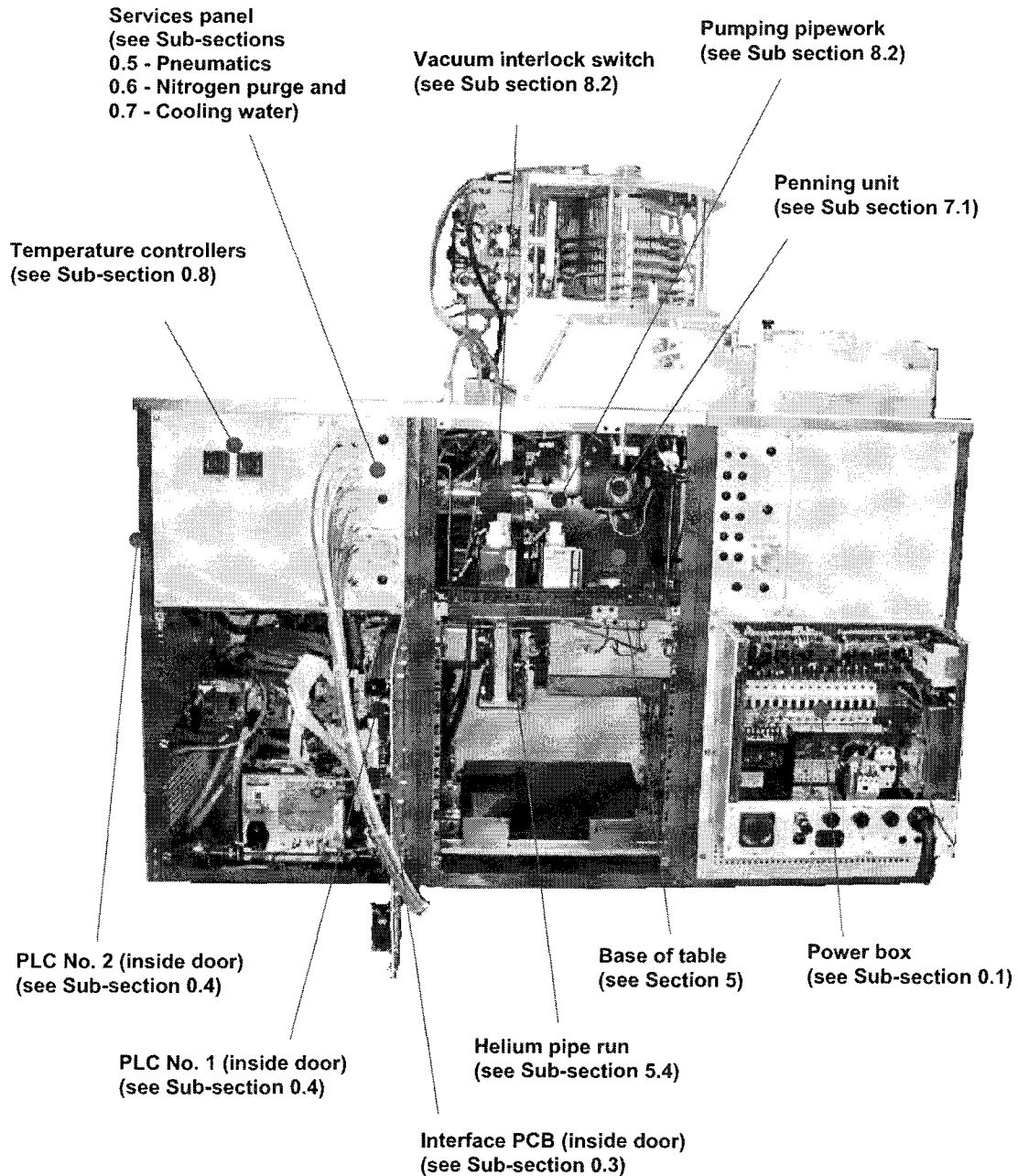

Section 0 - System Common Components

Section 0 - System Common Components	1
100-0-RIE Base unit.....	2
0.1 Power box.....	2
0.2 Control panel	4
0.3 PCBs.....	5
0.4 Programmable Logic Controllers (PLCs)	6
0.5 Pneumatic control components.....	7
0.5 Pneumatic control components (continued)	8
0.6 Nitrogen purge line	9
0.7 Water cooling circuits	10
0.8 Heating circuits	11
0.9 System common components option spares	12

100-0-RIE Base unit

0.1 Power box

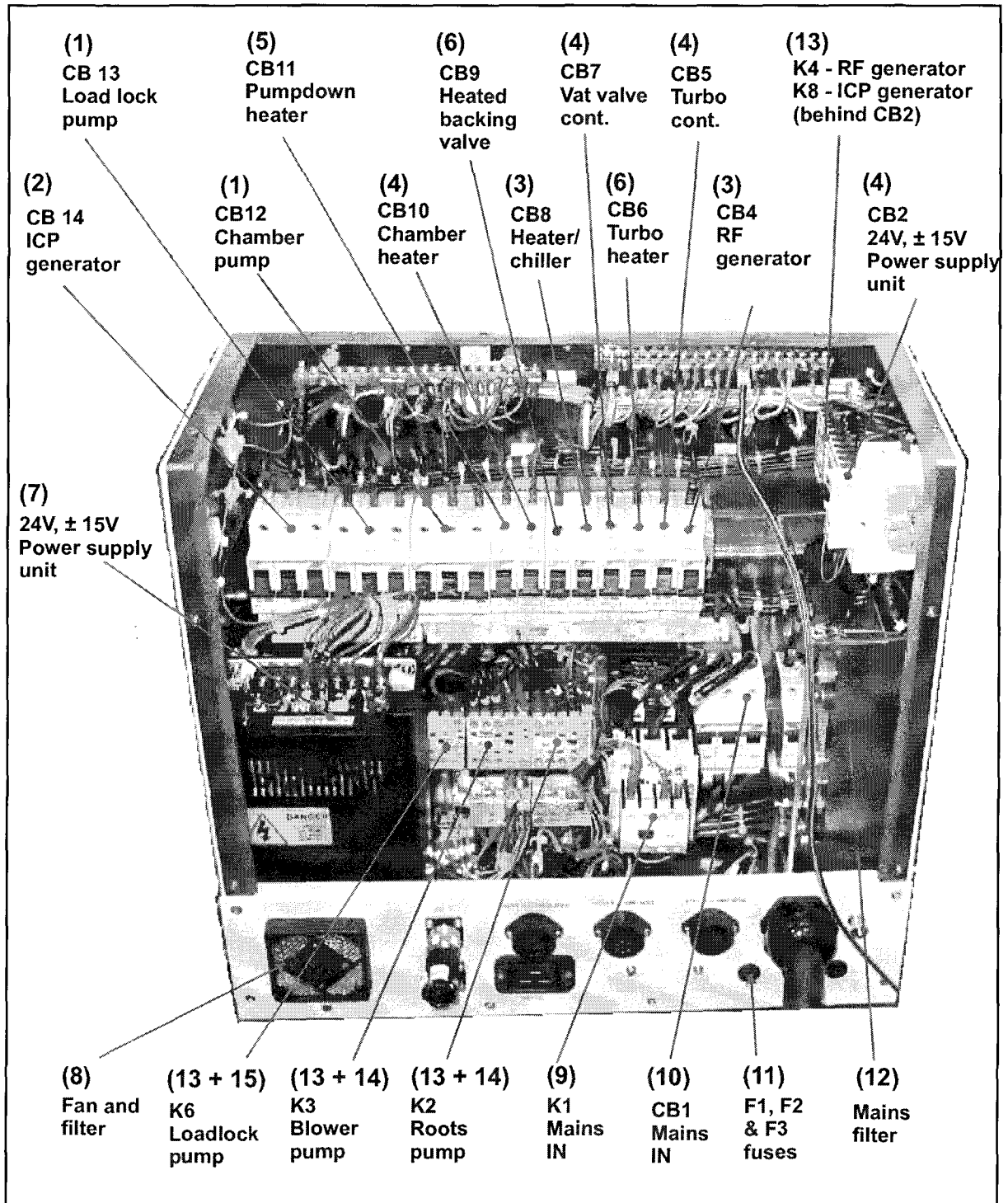

Note: The photograph above is a typical example of a PSU. MCBs (CB1, CB2 etc.) may vary between machines according to the voltage applied (415V or 208V) and the equipment supplied. When ordering MCBs, please quote the component number (e.g.CB6), the number of sections (e.g. 1, 2 or 3 phase) and the part number written on the component.

Item	Part No.	Description
(1)	EFM1606	K.M. SLOW MCB TRIPLE POLE 6A (CB12 & CB13)
(2)	EFM1620	K.M. SLOW MCB TRIPLE POLE 20A (CB14)
(3)	EFM1410	K.M. SLOW MCB SINGLE POLE 10A (CB4 & CB8)
(4)	EFM1406	K.M. SLOW MCB SINGLE POLE 6A (CB2, CB5, CB7 & CB10)
(5)	EFM1404	K.M. SLOW MCB SINGLE POLE 4A (CB11)
(6)	EFM1402	K.M. SLOW MCB SINGLE POLE 6A (CB6 & CB9)
(7)	EXP2415	MULTI O/P PSU 24V/4A,+/-15V/2.5A
(8)	EFA1060	FAN 62mm ULTRASLIM AXIAL 24Vdc
(8)	EFA1061	FAN FILTER RFI 60/62 mm
(9)	EGB2032	CONTACTOR 35A 24VDC DIL0AM KM (K1)
(9)	EGB2000	CONTACTOR DIODE MODULE (FOR K1)
(10)	EFM1632	K.M. SLOW MCB TRIPLE POLE 32A (CB1)
(11)	EFH2010C	FUSE HOLDER PANEL MTG 20mm (FS1 - FS3)
(11)	EFF2030	INS BOOT 200mm FUSE
(11)	EFB2030C	FUSE 20mm HBC ANTISURGET 3.15A (FS3)
(11)	EFF2120C	FUSE 20mm HBC ANTISURGET 2A (FS1 & FS2)
(12)	EFI0050	MAIN FILTER 3PHASE 50A
(13)	EGB3022	CONTACTOR 20A 24VDC MIN (K2, K3, K4, K6 & K8)
(14)	EGT0058	O/L RELAY 5.5-8A MIN (1 EACH FOR K2 & K3)
(15)	EGT0057	O/L RELAY 3.7-5.5A MIN (FOR K6)

0.2 Control panel

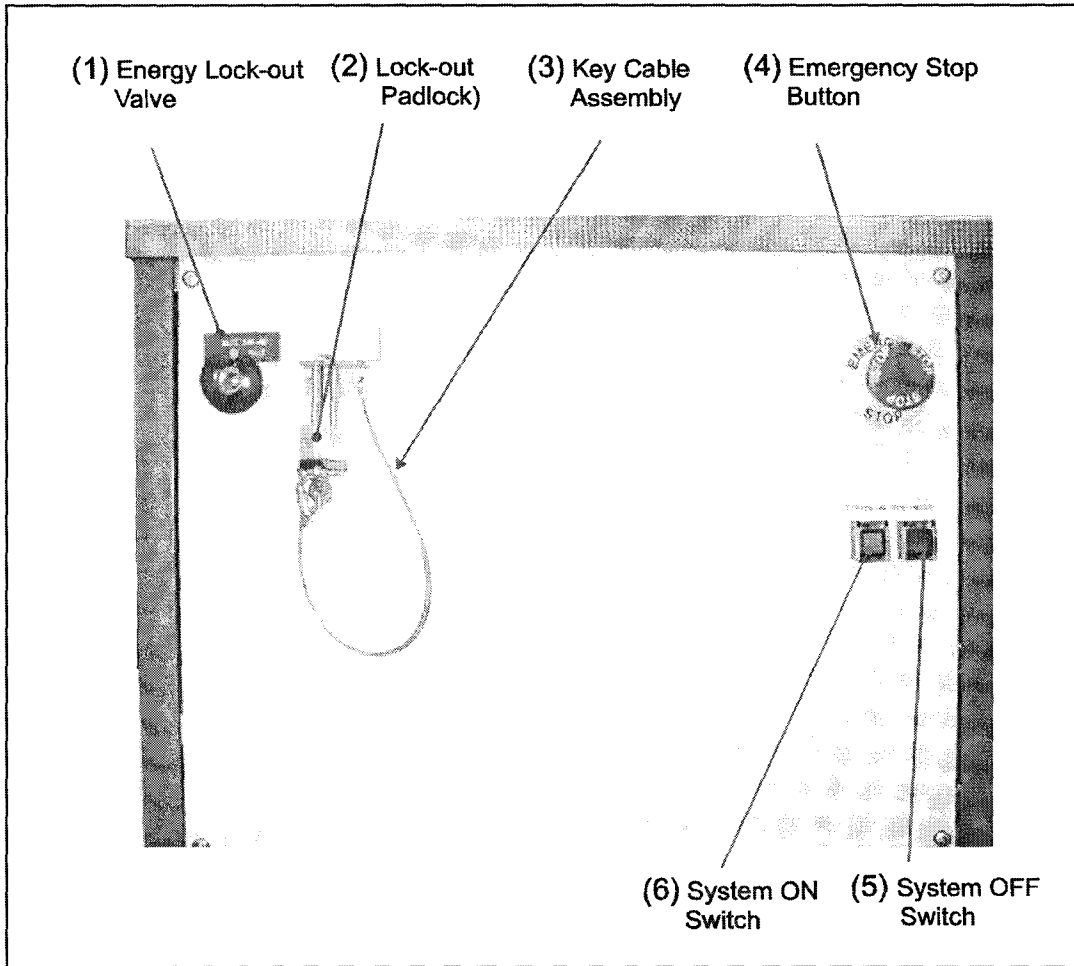

Item	Part No.	Description
(1)	G/AIR/VLV/559	LOCKOUT VALVE - 1/8 NPT
(2)		LOCKOUT VALVE PADLOCK
(3)	MA00D15883	KEY CABLE ASSEMBLY
(4)	ESM0201	EMERGENCY STOP BUTTON
(5)	ESM0200C	SYSTEM OFF SWITCH
(5a)	ESZ0000C	GREEN LENS FOR OFF SWITCH
(5b)	EPP0001C	CLEAR HINGED COVER
(5c)	EFL2002	BULB
(6)	ESM0200C	SYSTEM ON SWITCH
(6a)	ESZ0001	RED LENS FOR OFF SWITCH
(6b)	EPP0001C	CLEAR HINGED COVER
(6c)	EFL2002	BULB

0.3 PCBs

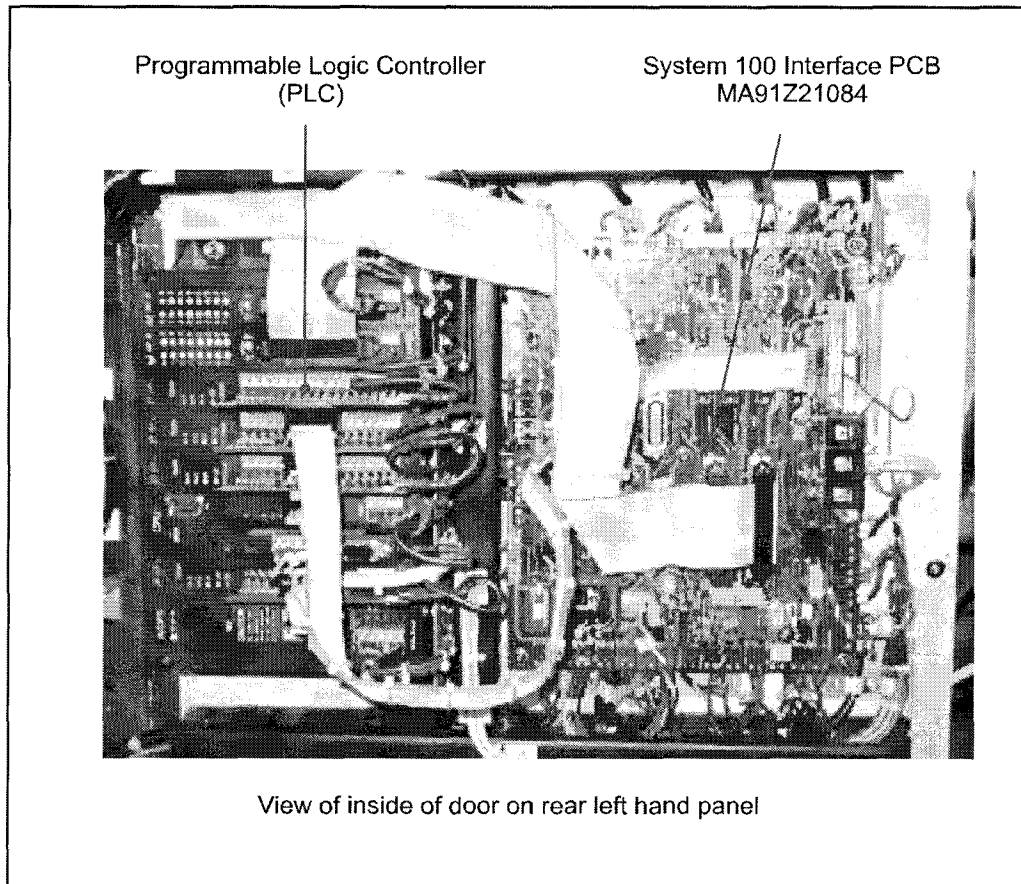

0.4 Programmable Logic Controllers (PLCs)

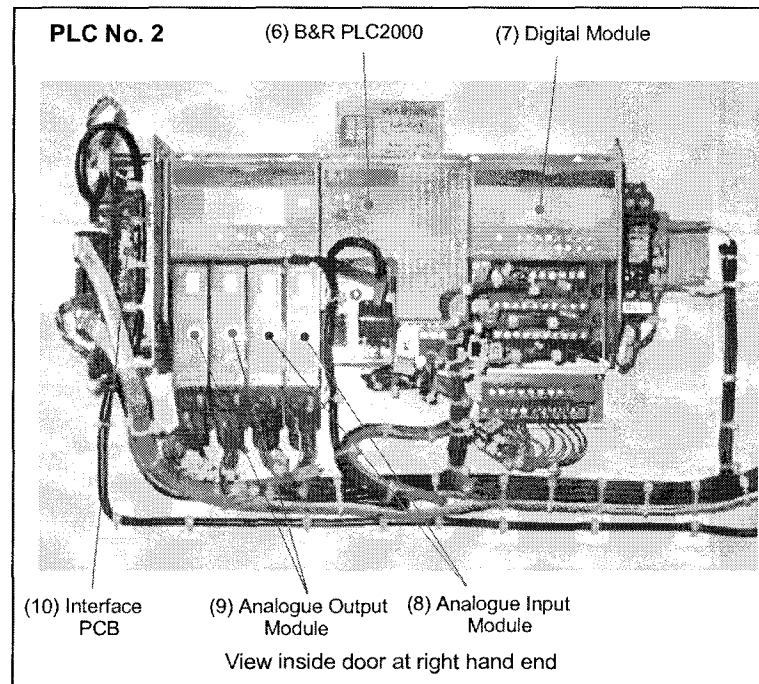
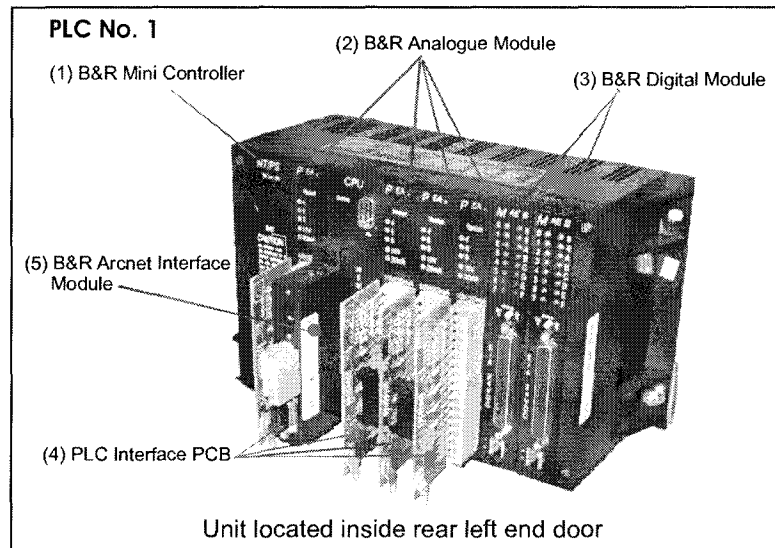

Item	Part No.	Description
(1)	EXP0699	B&R MINICONT WITH CARDS, NO MEM
(2)	EXP0725	B&R ANALOGUE MODULE 4I/P 4O/P
(3)	EXP0730	B&R DIGITAL MODULE 16I/P 16 O/P
(4)	MA81Z16005	PLC INTERFACE PCB FOR ANALOG C
(5)	EXP0750	B&R ARCNET INTERFACE TYPE- EE32-0
(6)	EXP0770	B&R PLC 2000 (PLC No. 2)
(7)	EXP0078	DIGITAL MODULE (PLC No. 2)
(8)	EXP0072	ANALOGUE INPUT MODULE (PLC No. 2)
(9)	EXP0074	ANALOGUE OUTPUT MODULE (PLC No. 2)
10	MA00Z24915	RS232/RJ68 BLUE PLC PCB (PLC No. 2)

0.5 Pneumatic control components

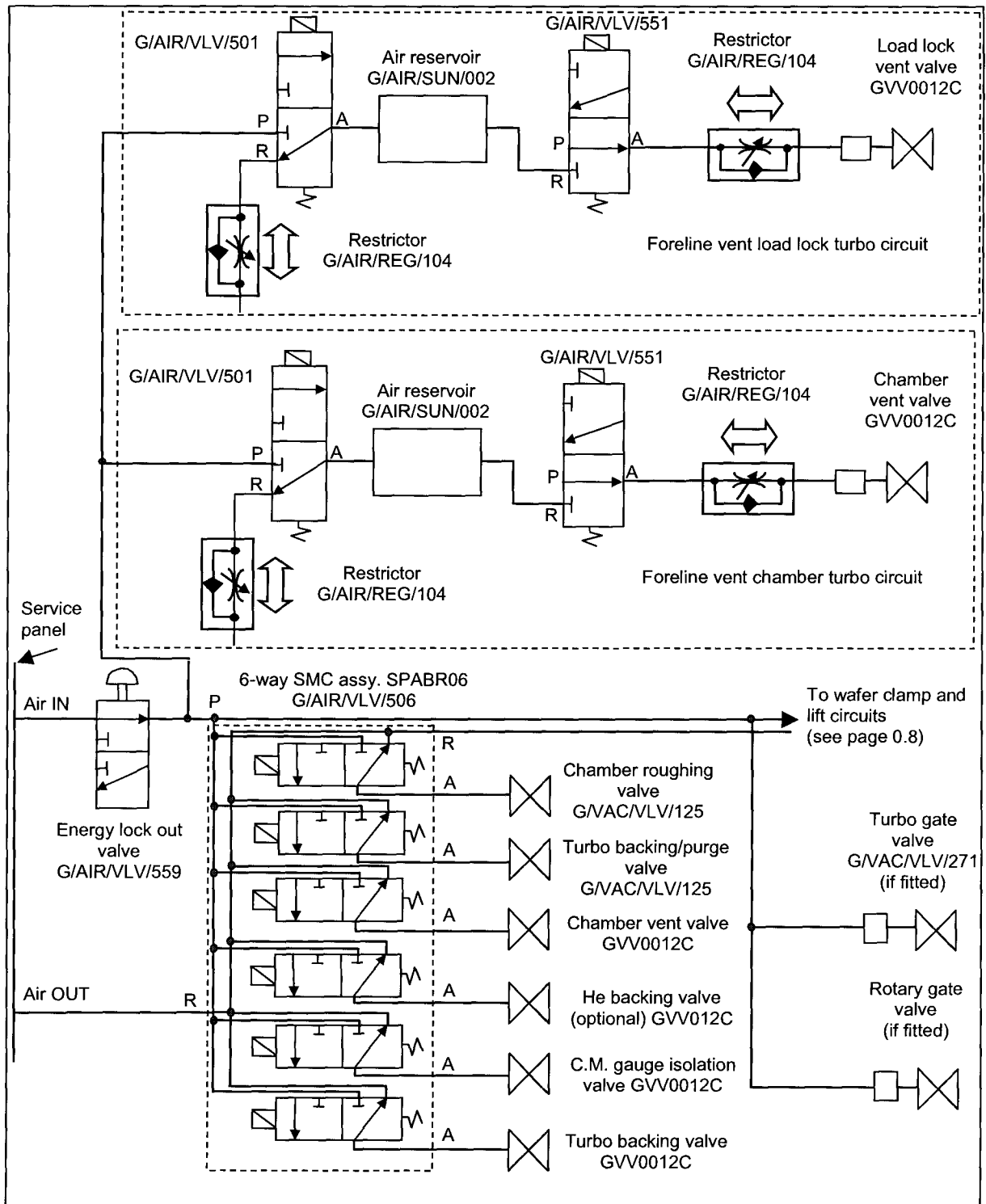

Note - Air tubing is blue

0.5 Pneumatic control components (continued)

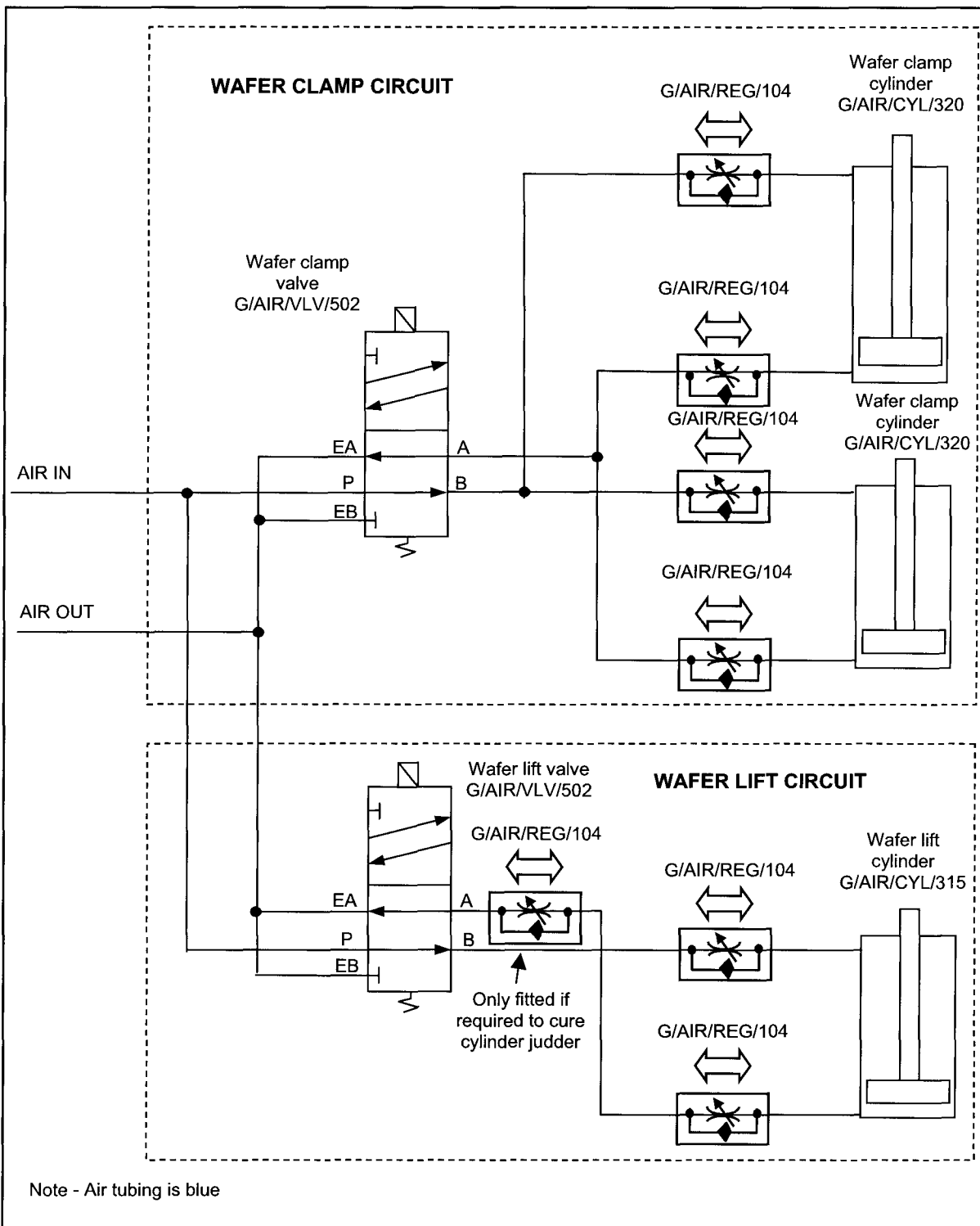

0.6 Nitrogen purge line

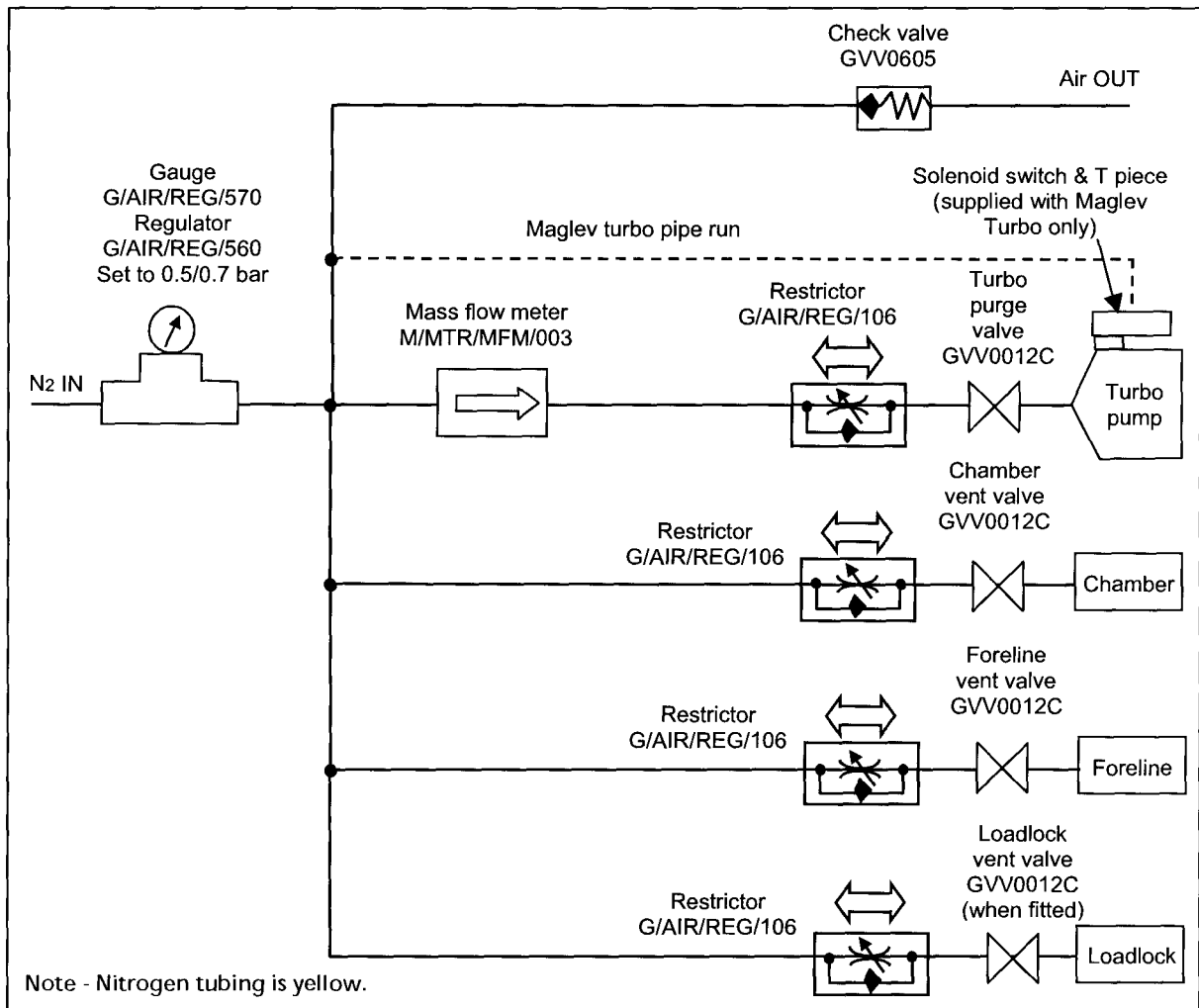

0.7 Water cooling circuits

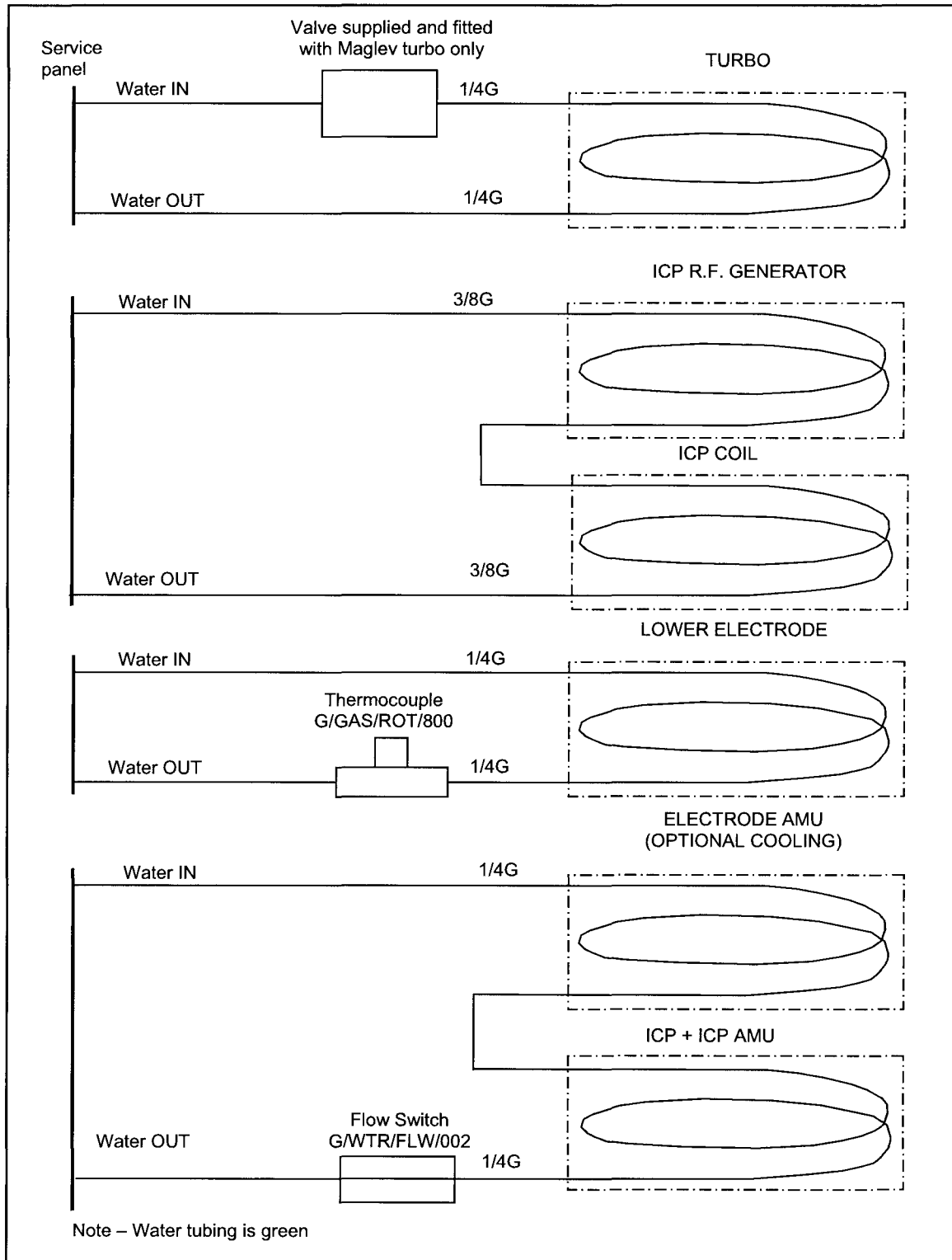

0.8 Heating circuits

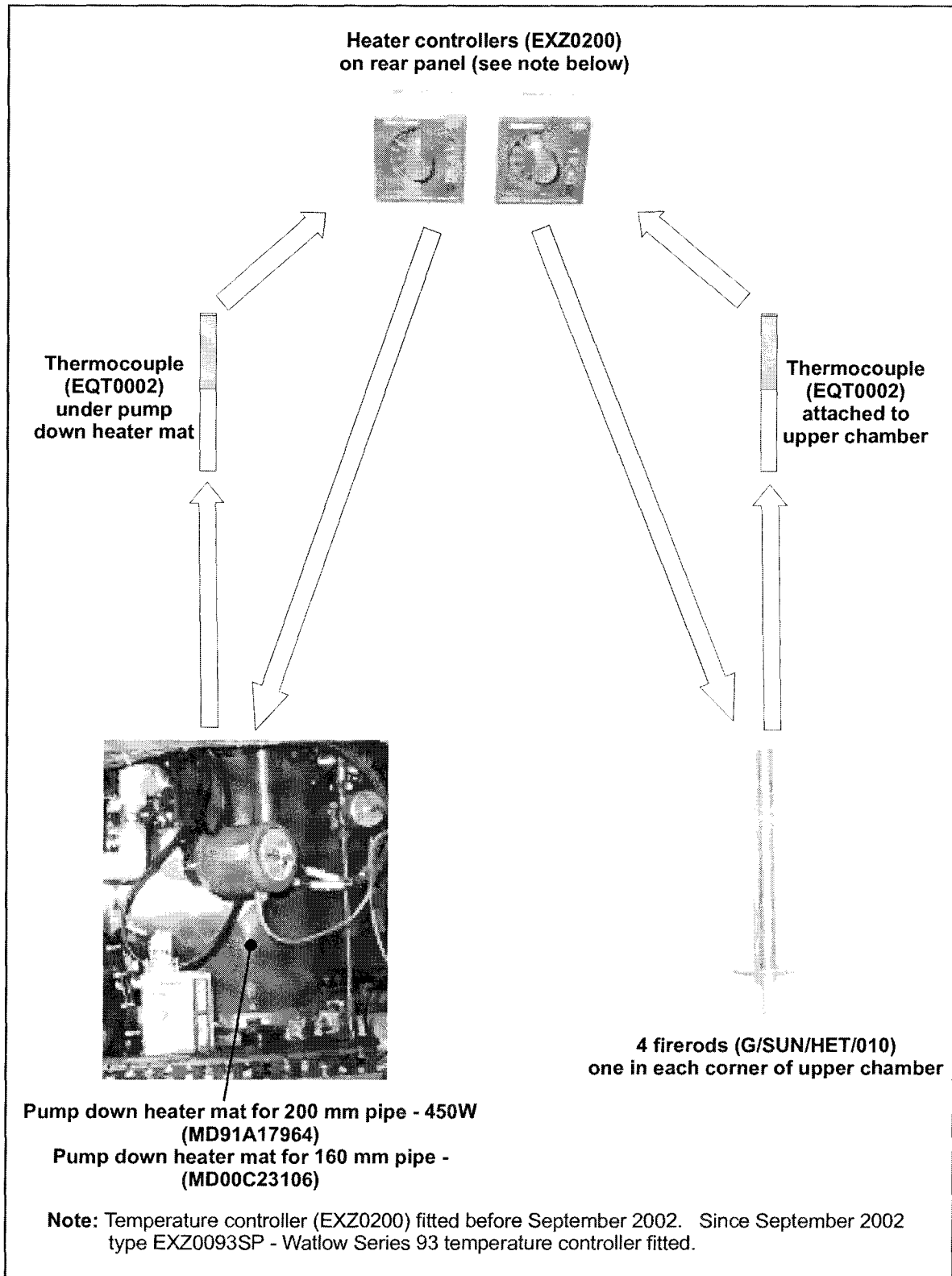

0.9 System common components option spares

OIPT Part No.	Qty	Description
100-S-CMP	1	Common 100 PM spares - See Sub-section 11.2
100-S-RIE	1	RIE 100 PM spares - See Sub-section 11.3
UNIVERSAL BASE CONSOLE WITH MODULE CONTROLLER (100-0-RIE)		
MA00Z22000	1	APC STEPPER MOTOR DRIVE ASSY
MA91Z21084	1	100 SYS PCB ASSY
POWER BOX ASSY - TOTAL (MA91Z18519)		
EGB2000	1	CONTACTOR DIODE MODULE KM
EGB3022	1	CONTACTOR 20A 24VDC MIN.KM
EGT0058	1	O/L RELAY ZE6 4-6A MIN. KM
EFM1606	1	K.M. SLOW MCB TRIPLE POLE 6A
EFB2010	3	INS BOOT 20 mm FUSE
EFF2120	3	FUSE 20 mm HBC ANTI-SURGE 2A
EFM1420	1	K.M. SLOW MCB SINGLE POLE 20A
ESM0201	1	EMERGENCY STOP BUTTON
ESZ8112	1	CONTACT BLOCK
EXP2415	1	MULTI O/P PSU 24V/4A +/- 15V/2.5A - Replaces EXP0012 and EXP0502
PLC UNIT		
EXP0700	1	B&R MINICONTROLLER 4 SLOT
EXO0725	1	B&R ANALOGUE MODULE.4
EXP0730	1	B&R DIGITAL MODULE 16 I/P
EXP0750	1	B&R ARCNET INTERF. EE32-0
EXP0272	1	PC ARCNET INTERFACE CARD (EXP0270 obsolete)
EXP0751	1	B&R MINICONTROLLER - Basic system consists; 4 off Analogue cards EXP0725, 2 off Digital cards EXP0730, 1 off Arcnet memory card EXP0750 and 1 off mini controller base EXP0700.
BASIC VACUUM KIT		
GVV0503	1	PTR PAUL SERIES 50 N/C
G/VAC/SEL/025	1	NW25 CENTERING RING

Section 3 - Process chambers

Section 3 - Process chambers	1
3.1 ICP180 chamber kit 200LF pipe (100-3-41C).....	2
3.2 Common process chamber option spares	4
3.3 ICP180 source option spares	4

3.1 ICP180 chamber kit 200LF pipe (100-3-41C)

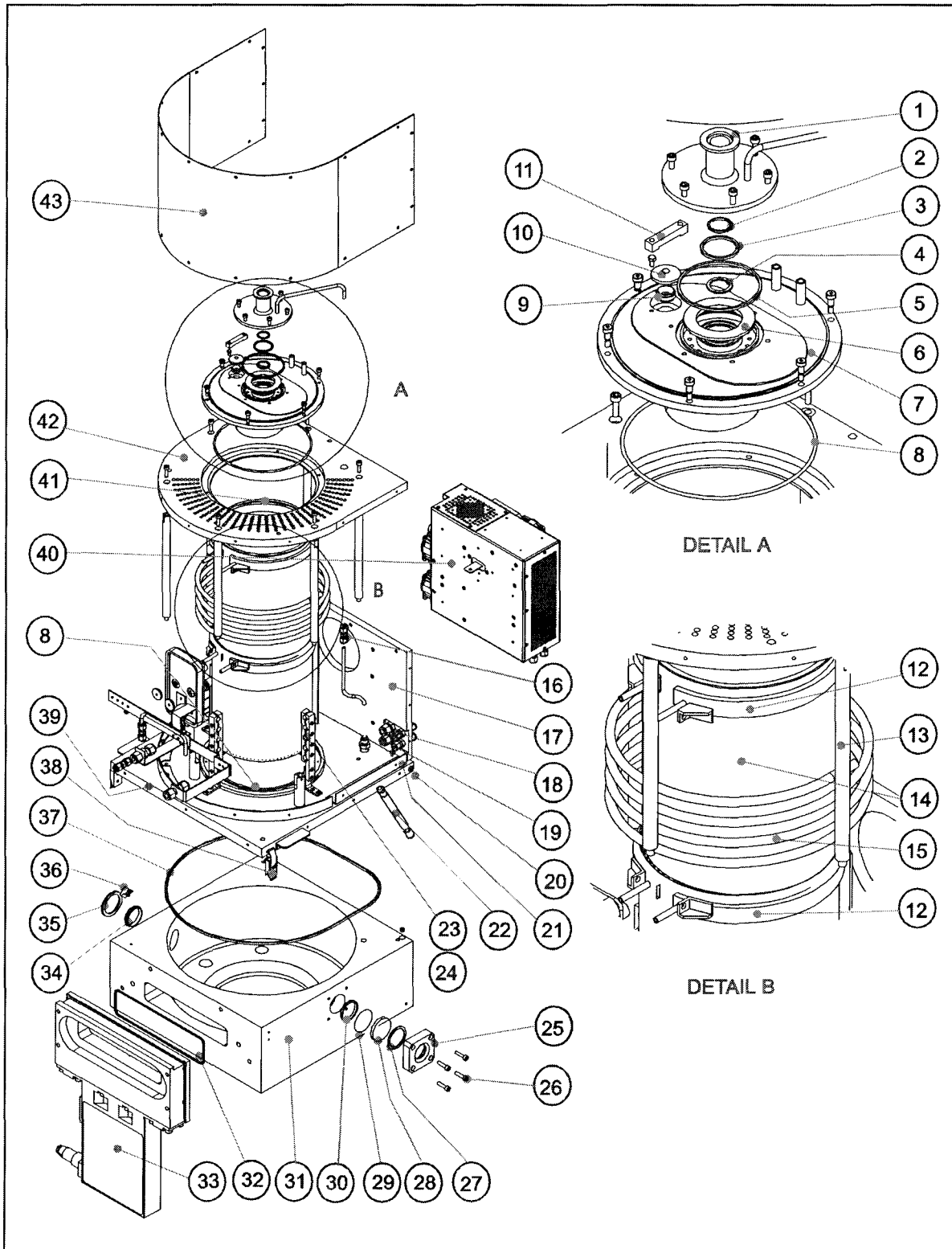

Item No.	OIPT Part No.	Qty	Description
	MA00Z22821		ICP180 (ALUMINA TUBE) HINGED ASSEMBLY
1	MD81C15834	1	NW25KF FLANGE (INTERFEROMETRY)
2	G/SEL/O-K/117	1	2.62 x 20.3 mm K'REZ 'O' RING BS117
3	G/SEL/O-K/219	1	3.53 x 32.9 mm K'REZ 'O' RING BS219
4	MD81D15869	1	GASKET
5	G/SEL/O-K/235	1	3.53 x 79.0 mm K'REZ 'O' RING BS235
6	MD81D15847	1	RING
7	MA00B21488	1	FLOATING TOP WELD MC ASSY-ICP
8	G/SEL/O-K/264	2	3.53 x 190.1 mm K'REZ 'O' RING BS264
9	G/VAC/SEL/015C	1	NW16 CENTRING RING ALI/VITON
10	G/VAC/FIT/323C	1	16KF BLANK FLANGE
11	MD00D18558	1	VALVE BLOCK
12	MD00B23127	1	CERAMIC TUBE WATER COOLING RING
13	MD00D21388	1	SUPPORT PILLAR
14	MD00B18547	1	RF SHIELD
15	MD00B18549	1	COIL (4) ICP SOURCE
16	G/GAS/FIT/284C	1	¼ UNION
17	MD00A23821	1	BACK PLATE HINGED
18	G/GAS/FIT/274C	2	¼ BULKHEAD UNION
19	G/GAS/FIT/276C	2	3/8 BULKHEAD UNION
20	G/SUN/BSH/116	4	8 x 12 x 12 mm OILITE BUSH CM16
21	MD91D17198	2	HINGE PIN
22	G/SUN/SPG/923	2	GAS SPG 6-60-220-MB-MB-RV400N
23	MD00D18551	3	SPACER BLOCK
24	MD00D18552	3	SPACER BLOCK HALF
25*	MD81D16140	1	WINDOW FLANGE
26*	G/FIX/S32/625	4	M6 x 25 mm S/S CAPHEAD SCREW
27*	MD81D14211	1	UV/RF FILTER
28*	M/4175D/01	1	WINDOW GASKET
29*	M/0651D/01	1	WINDOW GLASS (6 mm PYREX)
30*	MA00D14711	1	NW40 CENTRING RING MOD
31	MD91D20353	1	CHAMBER 200LF STANDARD
32	G/SEL/O-V/263C	1	3.5 x 196.4 mm VITON 'O' RING BS263 (PART OF ITEM 33 AND MOUNTED ON ITEM 33)
33	G/VAC/MLV/930	1	MONVAT VLV 46 x 236 02010-BA24
34	G/VAC/SEL/040C	1	NW40 CENT. RING ALI/VITON
35	G/VAC/FIT/327C	1	40KF BLANK FLANGE
36	G/VAC/CLP/311C	4	CLAWS DN25 1SO-KF.BP220366-T
37	G/SEL/O-V/384C	1	5.3 x 380.37 mm VITON 'O' RING 200-384
38	G/SUN/CAB/850	2	OVER CENTRE DRAW LATCH
39	MD00A22716	1	LID (HINGED ICP180)
40	MA00A23828	1	AUTOMATCH ASSY. (VAC CAP) ICP180
41	MD00C18541	1	QUARTZ TUBE (ICP SOURCE)
41a	MD00C18542	1	ALUMINA TUBE (ICP SOURCE) - ALTERNATE TO ITEM 41
42	MD00A21385	1	TOP PLATE (ICP)
43	MD00A23852	1	ICP180 SIDE COVER
* 25 to 30	MA91Z17161		CHAMBER VIEWPORT KIT

3.2 Common process chamber option spares

OIPT Part No.	Qty	Description
ICP 180 SOURCE (180 mm DIAMETER)		
MD00D18559	1	PERSPEX WINDOW
MD00D18684	1	WINDOW MESH
MD81D15869	1	GASKET
MD00C18541	1	QUARTZ TUBE (ICP SOURCE)
MD00C18542	1	ALUMINA TUBE (ICP SOURCE)
MD00B18547	1	ELECTROSTATIC SHIELD
G/VAC/FIT/978	2	25 O/D x 2 mm SAPPHIRE WINDOW
G/SEL/O-K/235	1	3.53 x 79.0 mm KALREZ 'O' RING BS235
G/SEL/O-K/219	1	3.53 x 32.9 mm KALREZ 'O' RING BS219
G/SEL/O-K/264	2	3.53 x 190.1 mm KALREZ 'O' RING BS264
G/SEL/O-K/117	1	2.63 x 20.3 mm KALREZ 'O' RING BS117
G/VAC/SEL/015	1	NW16 CENTERING RING ALUMINIUM
G/VAC/SEL/025	1	NW25 CENTERING RING
G/VAC/FIT/980	1	SIGHT GLASS (NW25)
ICP PROCESS CHAMBER WITH SINGLE VIEWPORT AND SIDE ACCESS DOOR FOR ICP180 SOURCE (100-3-41C)		
G/VAC/SEL/040	1	NW40 CENTERING RING
G/GAS/FIT/614	1	¼ RETAINING GASKET
G/SEL/O-V/265	1	3.5 x 196.4 mm VITON 'O' RING BS265
G/SEL/O-V/268	1	3.5 x 215.5 mm VITON 'O' RING 200-268

3.3 ICP180 source option spares

OIPT Part No.	Qty	Description
G/SUN/DWL/920	2	S/S DOWEL 10.006/10
G/VAC/SUN/032	1	EDWARDS VACUUM INTERLOCK SWITCH
ESZ91007	1	MICRO SWITCH 331-45
G/VAC/SEL/040	1	NW40 CENTERING RING
G/SEL/O-V/269	1	3.5 x 221.85 mm VITON 'O' RING 200-269
G/VAC/VLV/930	1	46 x 236 MESC VALVE (ALUMINIUM)
CHAMBER AND HEATER PUMP DOWN KITS		
EXZ0200	1	SERIES 2 ON/OFF HEATER CONTROL
EQT0002	1	TH'COUPLE TYPE K 200/C (replaces EQF0100)
G/SUN/HET/010	1	FIREROD ½" x 101LG 240V 250W

Section 5 - Lower electrode

Section 5 - Lower electrode	1
5.1 Standard He backed lower electrode with centrally positioned 3-pin lift and wafer clamp assembly (100-5-36A) / (100-5-36A/01 - Anodised)	2
5.2 RIE + He vari height table (100-5-26A).....	4
5.3 Cryo table (100-5-12A) / (100-5-12A/1 - Anodised)	6
5.4 Helium pipe run	8
5.5 Lower electrode option spares.....	9

5.1 Standard He backed lower electrode with centrally positioned 3-pin lift and wafer clamp assembly (100-5-36A) / (100-5-36A/01 - Anodised)

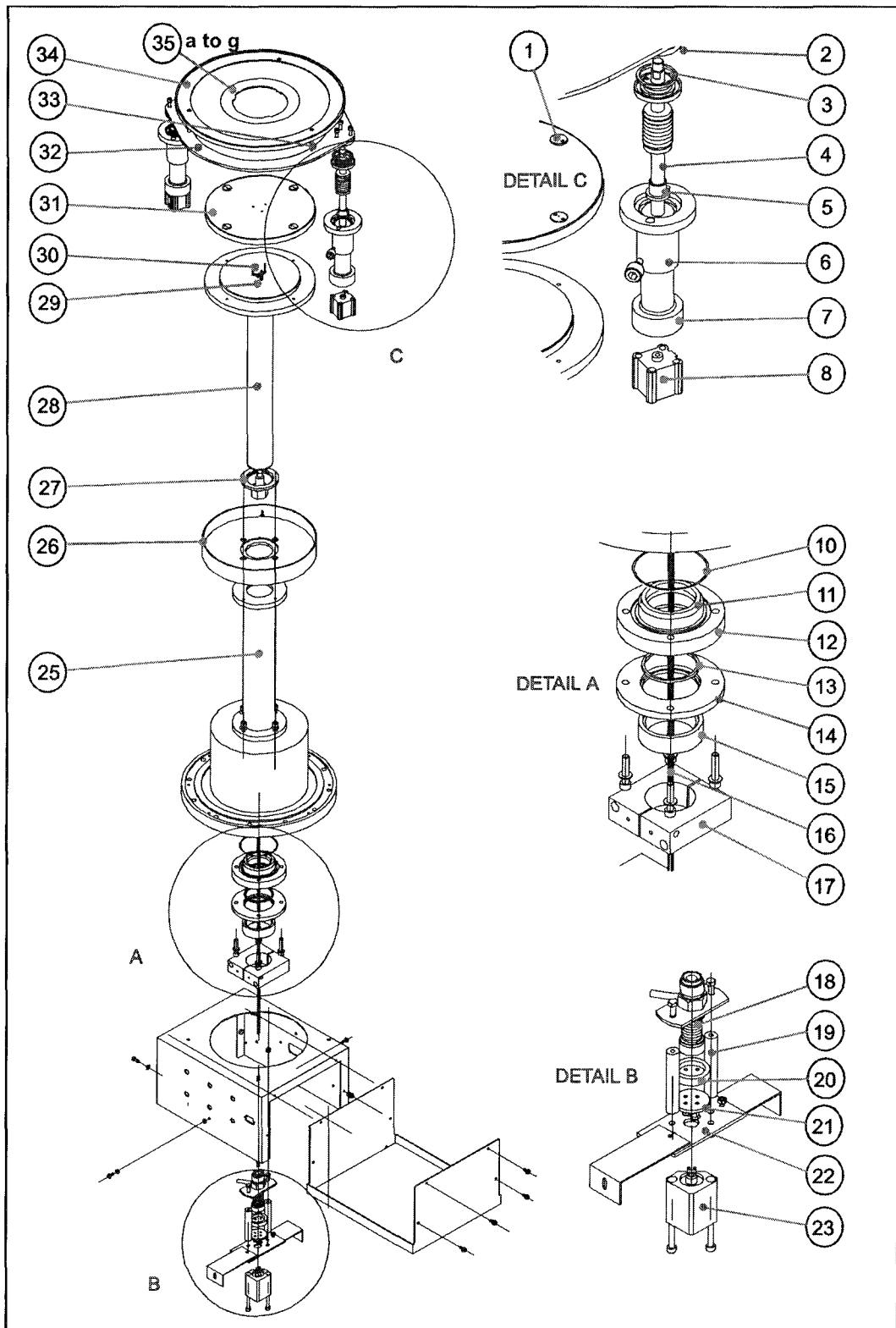

Item No. in illustration	OIPT Part Number	Description
	100-5-36A	STANDARD He BACKED LOWER ELECTRODE
	100-5-36A/01	STANDARD He BACKED LOWER ELECTRODE - ANODISED
	MA91Z21747	RIE TABLE ASSY (3 PIN LIFT)
	MA91A22537	WAFER CLAMP ASSEMBLY 200 PORT
	MA91C20442	HELIUM PIPE RUN ASSEMBLY
1	MD91D21723	TABLE TOP PLUG
1a	MA91D21724	TABLE TOP PLUG ANODISED (ALT TO ITEM 1)
2	MD91D22533	WAFER CLAMP RING SUPPORT
3	G/SEL/O-V/218C	3.5 x 31.3 mm VITON 'O' RING BS218
4	MA91D17600	PIN WELDED ASSEMBLY
5	MD91D17604	FLANGED BUSH
6	MD91D17602	HOUSING
7	G/SUN/BSH/123	OILITE BUSH 16 x 20LG QM21-20
8	G/AIR/CYL/320	20 mm CYLINDER CDQ2B20-20D
9	G/SUN/SPG/012	COMP. SPRING LEE No. LCM-050C-5 (NOT SHOWN)
10	G/SEL/O-V/146C	2.6 x 66.3 mm VITON 'O' RING BS146
11	MD81D14110	COMPRESSION RING
12	MD81C14107	TABLE FEEDTHROUGH
13	G/SEL/O-V/829C	3.5 x 47.6 mm VITON 'O' RING BS829
14	MD81D14109	CLAMPING FLANGE
15	MD81D14111	SPACER
16	MD91D21715	PIN LIFT ROD
17	MD81C14104	WATER COOLED CLAMP
18	MA91C19809	BELLOWS WELDED ASSEMBLY
19	MD91D19679	CYLINDER SPACER
20	MD91D21408	SPRING SPACER
21	MD91D21407	SPRING SHOULDER
22	MD91D23589	CYLINDER MOUNTING BRACKET
23	G/AIR/CYL/315	AIR CYLINDER CDQ2B20-15D (SMC)
24	G/SUN/SPG/008	SPRING COMP. O/D 31.75 x 50.8 x 2.6 (NOT SHOWN)
25	MD91B19672	TABLE SUPPORT TUBE
26	MD91C19935	DARK SPACE SHIELD 200 DIA
27	MD81D14116	ISOLATOR WASHER (RIE TABLE)
28	MA91B21716	TABLE ASSEMBLY (FOR PIN LIFT TOP)
29	MD91C21713	PIN LIFT STAR
30	MD91D21714	PIN LIFT ROD
31	MD91C21712	TABLE UPPER SURFACE
31a	MA91C21725	TABLE UPPER SURFACE ANODISED (ALT TO ITEM 31)
32	MD91B22531	WAFER CLAMP BOTTOM PLATE
33	MD91D22532	WAFER CLAMP SUPPORT ROD
34	MA91B22491	RETAINING RING FOR WAFER CLAMP
35a	MD91B22327	2" DIA WAFER CLAMP - QUARTZ
35b	MD91B22277	3" DIA WAFER CLAMP - QUARTZ
35c	MD91B22328	4" DIA WAFER CLAMP - QUARTZ
35d	MD91B22938	4¼" DIA WAFER CLAMP - QUARTZ
35e	MD91B24693	5" DIA WAFER CLAMP - QUARTZ
35f	MD91B22329	6" DIA WAFER CLAMP - QUARTZ
35g	MD91B23026	8" DIA WAFER CLAMP - QUARTZ
	G/AIR/VLV/502	SMC ASSY. VZ3140/5MNZ/001
	G/AIR/REG/104	INLINE FLOW REG. AS1001F-04
	G/AIR/CYL/807	REED SWITCH SMC No. D-A73L
	EQT0014	TYPE 17 Pt RES THERMOMETER

Note: See sub Section 0.5 for hydraulic components and sub Section 5.4 for the helium pipe run.

5.2 RIE + He variable height table (100-5-26A)

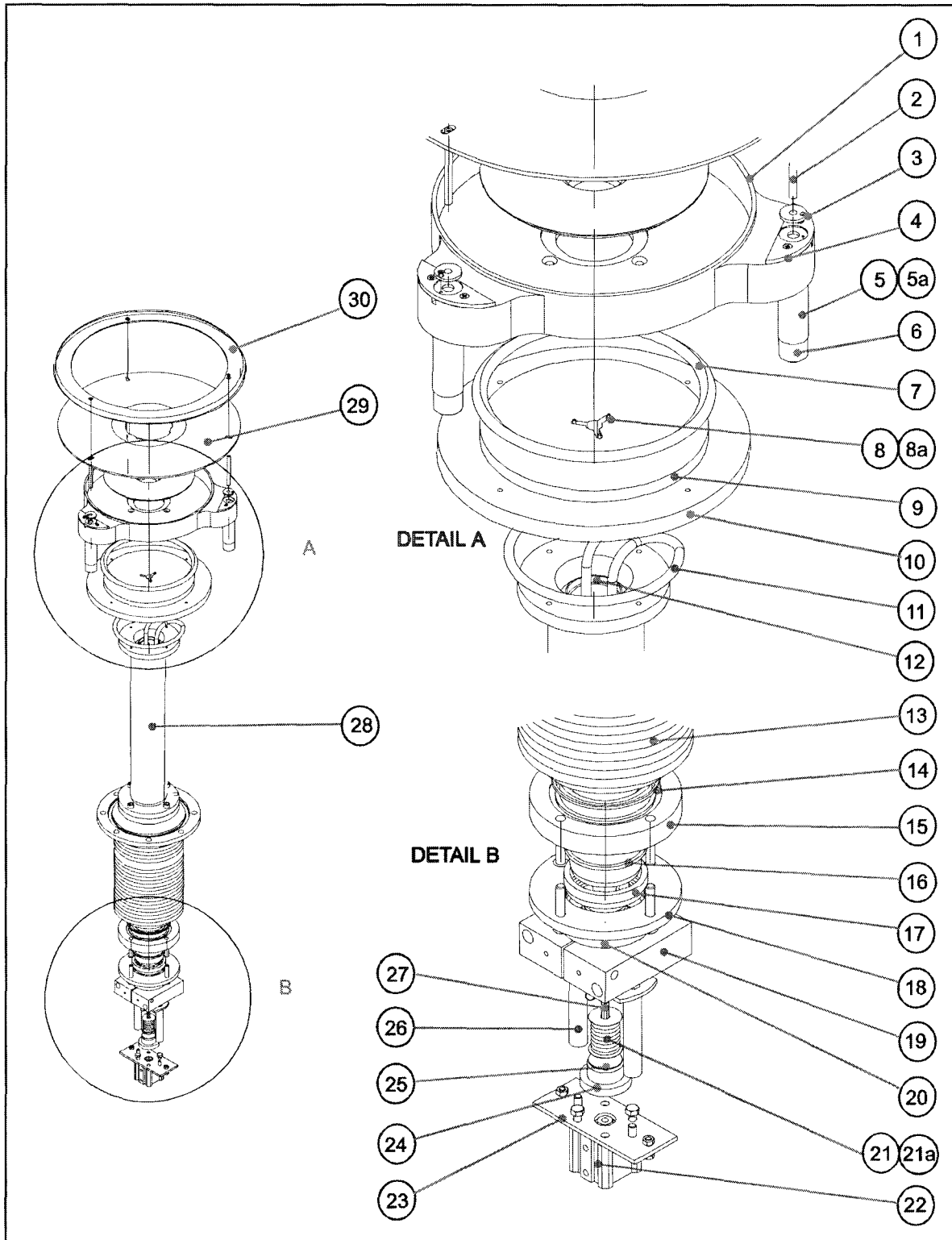

Item No. in illustration	OIPT Part Number	Description
	100-5-26A	RIE + He VARI HEIGHT TABLE
	MA91Z21031	ELECTRODE LWR RIE He VARI + CLAMP
	MA91A21088	WAFER CLAMP ASSEMBLY
	MA91C20442	HELIUM PIPE RUN ASSEMBLY
1	MD91B23034	DARK SPACE SHIELD
2	MD91D21077	ROD (3 OFF)
3	MD91D21077	BUSH (3 OFF)
4	MA91D21074	CAP (3 OFF)
5	MD91D21288	SLEEVE (WAFER CLAMP) (3 OFF)
5a	G/SUN/SPG/017	SPRING COMPRESSION D22470 (INSIDE ITEM 5)
6	MD91D21287	PLUG (WAFER CLAMP) (3 OFF)
7	MA91D21352	FRICTION WELD JOINT 3/8" TUBE
8	MD91D21714	WAFER LIFTING PIN (3 OFF)
8a	MD91C21713	PIN LIFT STAR
9	MD91B21711	TABLE MAIN BODY
10	MD91C19695	TABLE LOWER PLATE (RIE)
11	MD91C21010	WATER COOLING TUBE
12	MD91C21011	TABLE SUPPORT TUBE
13	MA91A19142	BELLOWS ASSEMBLY
14	G/SEL/O-V/146C	2.6 x 66.3 mm VITON 'O' RING BS146
15	MD81C14107	TABLE FEEDTHROUGH
16	G/SEL/O-V/829C	3.5 x 47.6 mm VITON 'O' RING BS829
17	MD81D14110	COMPRESSION RING
18	MD81D14109	CLAMPING FLANGE
19	MD81C14104	WATER COOLED CLAMP
20	MD81D14111	SPACER
21	MA91C19809	BELLOWS WELDED ASSEMBLY
21a	G/SUN/SPG/008	SPRING COMP. O/D 31.75 x 50.8 x 2.6 (INSIDE ITEM 21)
22	G/AIR/CYL/315	AIR CYLINDER CDQ2B20-15D (SMC)
23	MD91D23589	CYLINDER MOUNTING BRACKET
24	MD91D21407	SPRING SHOULDER
25	MD91D21408	SPRING SPACER
26	MD91D19679	CYLINDER SPACER
27	MD91D23105	PIN LIFT ROD
28	MD91B21005	TABLE SUPPORT TUBE
29	MD91B22277	3" DIA WAFER CLAMP - QUARTZ - SEE SUB-SECTION 5.1 for OTHER AVAILABLE WAFER CLAMPS
30	MA91B22491	RETAINING RING FOR WAFER CLAMP
	G/AIR/VLV/502	SMC ASSY. VZ3140/5MNZ/001
	G/AIR/REG/104	INLINE FLOW REG. AS1001F-04
	G/AIR/CYL/807	REED SWITCH SMC No. D-A73L
	G/SUN BRG/010	LINEAR MOTION GUIDE
	G/SUN/ACT/002	TABLE LIFT ACTUATOR
	EQT0014	TYPE 17 Pt RES THERMOMETER

Note: See sub Section 0.5 for hydraulic components and sub Section 5.4 for the helium pipe run.

5.3 Cryo table (100-5-12A) / (100-5-12A/1 - Anodised)

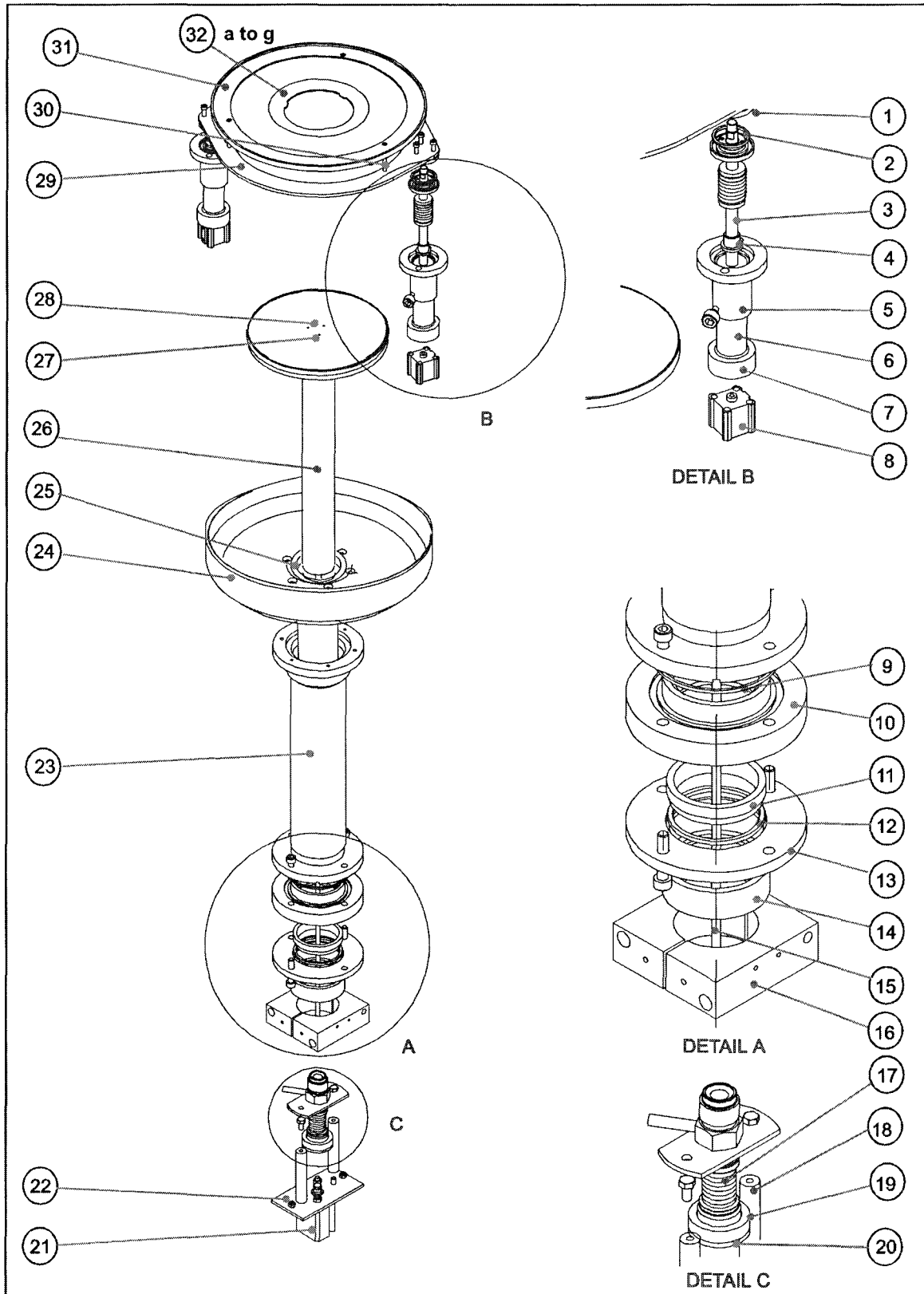

Item No. in illustration	OIPT Part Number	Description
	100-5-12A	CRYO TABLE
	100-5-12A/1	CRYO TABLE - ANODISED
	MA91Z20975	TABLE ASSY (-150/+140C)
	MA91A20949	ELECTRODE LOWER ASSY (-150/+140C) ANODISED
	MA91A22537	WAFER CLAMP ASSEMBLY 200 PORT
	MA91C20442	HELIUM PIPE RUN ASSEMBLY
1	MD91D22533	WAFER CLAMP RING SUPPORT
2	G/SEL/O-V/218C	3.5 x 31.3 mm VITON 'O' RING BS218
3	MA91D17600	PIN WELDED ASSEMBLY
4	MD91D17604	FLANGED BUSH
5	MD91D17602	HOUSING
6	G/SUN/SPG/012	COMP. SPRING LEE No. LCM-050C-5 (NOT SHOWN)
7	G/SUN/BSH/123	OILITE BUSH 16 x 20LG QM21-20
8	G/AIR/CYL/320	20 mm CYLINDER CDQ2B20-20D
9	G/SEL/O-V/146C	2.6 x 66.3 mm VITON 'O' RING BS146
10	MD81C14107	TABLE FEEDTHROUGH
11	MD81D14110	COMPRESSION RING
12	G/SEL/O-V/829C	3.5 x 47.6 mm VITON 'O' RING BS829
13	MD81D14109	CLAMPING FLANGE
14	MD81D14111	SPACER
15	MD91D19828	PUSH ROD
16	MD81C14104	WATER COOLED CLAMP
17	MA91C19809	BELLOWS WELDED ASSEMBLY
18	MD91D19679	CYLINDER SPACER
19	MD91D21408	SPRING SPACER
20	MD91D21407	SPRING SHOULDER
21	G/AIR/CYL/315	AIR CYLINDER CDQ2B20-15D (SMC)
22	MD91D23589	CYLINDER MOUNTING BRACKET
22a	G/SUN/SPG/008	SPRING COMP. O/D 31.75 x 50.8 x 2.6 (NOT SHOWN)
23	MD91B20935	DSS SUPPORT TUBE
23a	MD91B20946	DSS SUPPORT TUBE ANODISED (ALT. TO ITEM 23)
24	MD91B20939	DARK SPACE SHIELD
24a	MD91B20945	DARK SPACE SHIELD ANODISED (ALT. TO ITEM 24)
25	MD91D20934	LOCATING RING
26	MA91A20947	ELECTRODE LOWER ASSEMBLY WELDED
26a	MA91B20944	ELECTRODE LOWER ANODISED (ALT. TO ITEM 26)
27	MD91C21713	PIN LIFT STAR (UNDER)
28	MD91D21714	PIN LIFT ROD (UNDER)
29	MD91B22531	WAFER CLAMP BOTTOM PLATE
30	MD91D22532	WAFER CLAMP SUPPORT ROD
31	MA91B22491	RETAINING RING FOR WAFER CLAMP
32a	MD91B22327	2" DIA WAFER CLAMP - QUARTZ
32b	MD91B22277	3" DIA WAFER CLAMP - QUARTZ
32c	MD91B22328	4" DIA WAFER CLAMP - QUARTZ
32d	MD91B22938	4¼" DIA WAFER CLAMP - QUARTZ
32e	MD91B24693	5" DIA WAFER CLAMP - QUARTZ
32f	MD91B22329	6" DIA WAFER CLAMP - QUARTZ
32g	MD91B23026	8" DIA WAFER CLAMP - QUARTZ
	G/AIR/VLV/502	SMC ASSY. VZ3140/5MNZ/001
	G/AIR/REG/104	INLINE FLOW REG. AS1001F-04
	G/AIR/CYL/807	REED SWITCH SMC No. D-A73L
	EQT0014	TYPE 17 Pt RES THERMOMETER

Note: See sub Section 0.5 for hydraulic components and sub Section 5.4 for the helium pipe run.

5.4 Helium pipe run

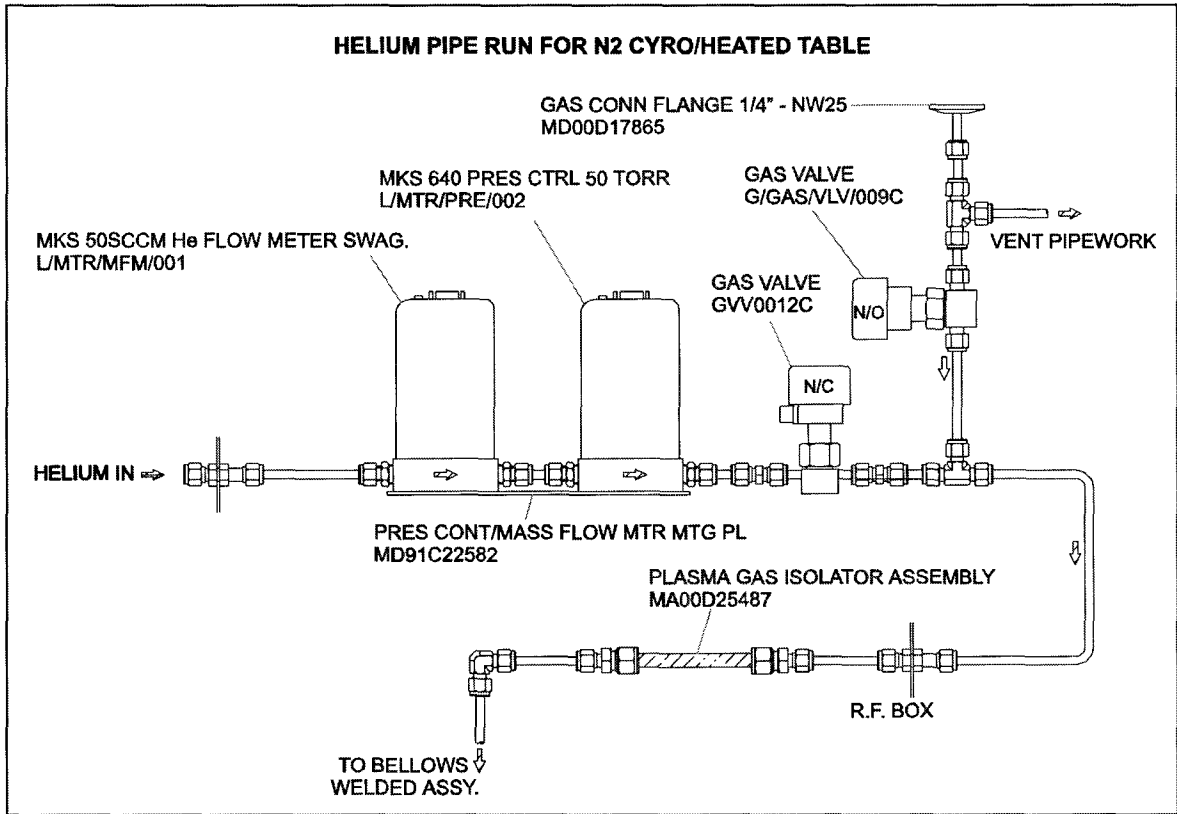

5.5 Lower electrode option spares

OIPT Part No.	Qty	Description
MA91Z21747	1	RIE TABLE ASSY. (3 PIN LIFT)
MA91C19809	1	BELLOWS WELDED ASSEMBLY
G/SUN/SPG/008	1	SPRING COMP. O/D 31.75 x 50.8 x 2.6
G/AIR/CYL/315	1	AIR CYLINDER CDW2820-15D
EQT0014	1	TYPE 17 Pt RES THERMOMETER
MD91D21723	4	TABLE TOP PLUG
MD91C21712	1	TABLE UPPER SURFACE
RIE HELIUM BACK COOLED LOWER ELECTRODE (100-5-36A)		
G/AIR/VLV/502	1	SMC ASSY. VZ3104/5MNZ/01
G/AIR/REG/104	1	IN LINE FLOW REGULATOR AS101F-04
HELIUM PIPE RUN ASSEMBLY (MA91C20442)		
L/MTR/MFM/001	1	MKS 5SCCM He FLOW METER SWAG.
L/MTR/PRE/002	1	MKS 640 PRESSURE CONTROLLER, 50 TORR
MA00D25487	1	PLASMA GAS ISOLATOR ASSEMBLY
GVV0012C	1	¼ SWAGE AIR CLOSED VALVE
G/GAS/VLV/601	1	CHECK VALVE 2PSI ¼" SWAGELOK
G/GAS/FIT/367C	2	10 mm PTFE FERRULE, BACK
G/GAS/FIT/366C	2	10 mm PTFE FERRULE, FRONT
WAFFER CLAMP ASSEMBLY 200 PORT (MA91A22537)		
MA91D17600	2	PIN WELDED ASSEMBLY
G/AIR/CYL/320	2	20 mm CYLINDER CDQ2B20-20D
G/SEL/O-V/218	2	3.5 x 31.3 mm VITON 'O' RING BS218
G/SUN/SPG/012	6	COMP. SPG. LEE No. LCM-050C-5
G/AIR/CYL/807	2	REED SWITCH SMC No. D-A73L

NOTES:

Section 6 - RF supplies and automatch

Section 6 - RF supplies and automatch	1
RIE 600W Generator + OPT AMU 200 pipe (100-6-200V)	3
6.1 Automatch assembly - vac cap etch 5-turn coil (MA00A23771).....	3
ICP180 FLOAT TOP ASSY. ALUMINA (100-6-56)	5
6.2 Automatch assembly - vac cap (MA00Z23828)	5
6.3 AMU control panel.....	6
6.4 RF generators	7
6.5 RF supplies and automatch option spares	8
6.6 RF supplies and automatch (vac cap) ICP180 option spares.....	8

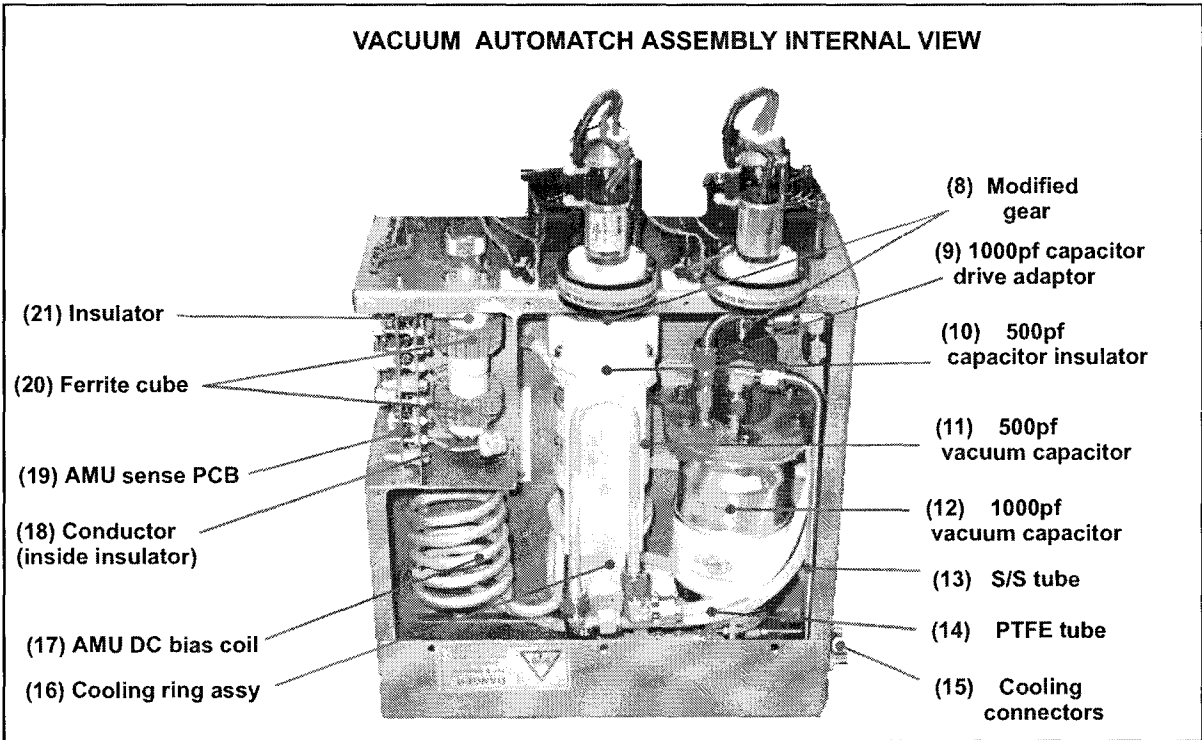
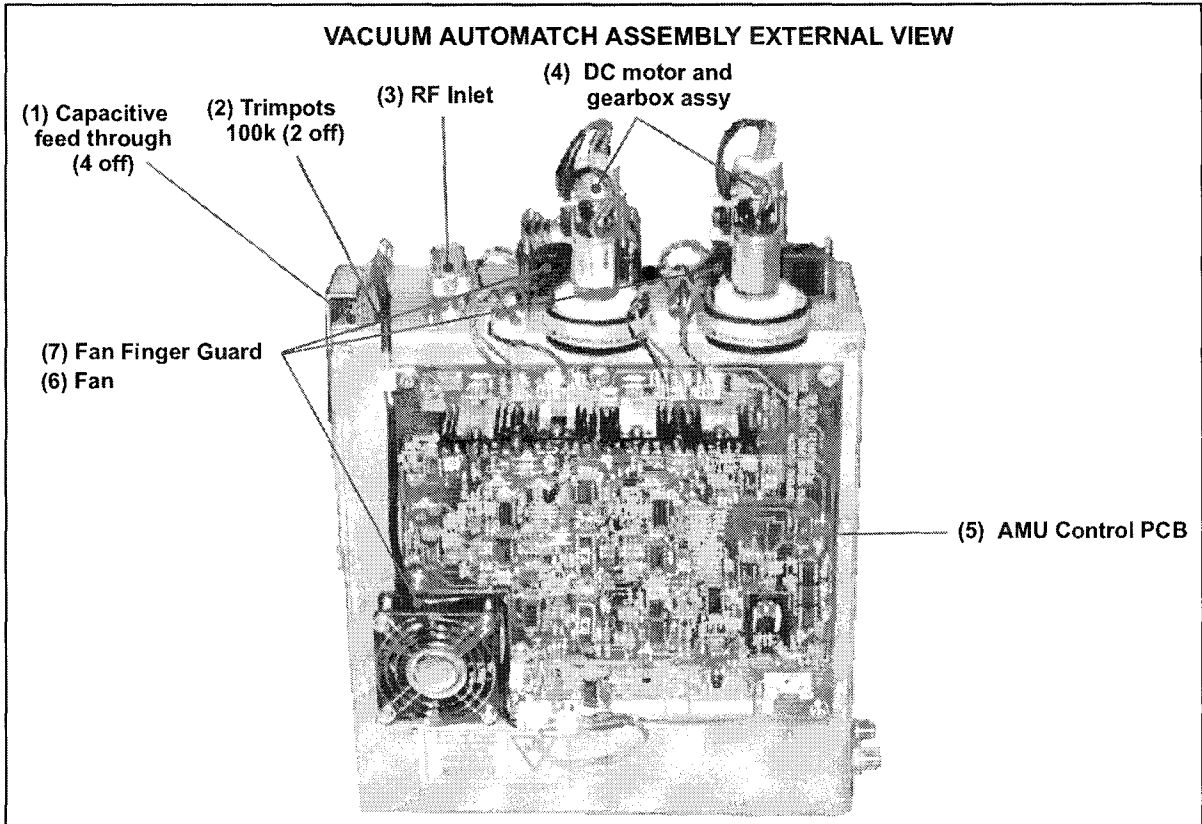

RIE 600W Generator + OPT AMU 200 pipe (100-6-200V)

OIPT Part No.	Description
L/GEN/RFG/101	AE RFX600A 230V(PASSIVE PANEL) RF GENERATOR
MA00A23771	AUTOMATCH ASSEMBLY
MA00B23328	AMU CONTROL PANEL ASSY

6.1 Automatch assembly - vac cap etch 5-turn coil (MA00A23771)

Item	OIPT Part No.	Qty	Description
1	ECC0001	4	CAPACITIVE FEED THRU 10,000 pf
2	ERU0511	2	TRIMPOT 100K (3006) SERIES
3	EPP0005	1	SOCKET G15007H RR N CHAS. (RF INLET CONNECTOR)
4	MA00D23738	2	MOTOR & GEARBOX ASSEMBLY
5	MA00Z20138	1	AMU CONTROL PCB ASSEMBLY
6	EFA0460C	3	FAN AXIAL 60 x 60 x 25.4 24 VDC
7	EFA1062	3	FAN FINGER GUARD 60/62
8	MA00D22225	2	MODIFIED GEAR
9	MD00D21224	1	1000 pf VACUUM CAPACITOR DRIVE ADAPTOR
10	MD00D21225	1	500 pf VACUUM CAPACITOR INSULATOR
11	L/CAP/VAR/106	1	500 pf VACUUM CAPACITOR
12	L/CAP/VAR/110	1	1000 pf VACUUM CAPACITOR
13	R/TUB/S/S/200C		¼" O/D x 20G 316L S/S ELPO
14	R/TUB/PTF/030		¼" O/D x 3/16" I.D PTFE TUBE
15	G/GAS/FIT/274C	2	COOLING CONNECTORS
16	MA00D23772	1	COOLING RING ASSEMBLY
17	MA00D20107	1	AMU DC BIAS COIL
18	MD00D21243	1	CONDUCTOR
19	MA00Z18209	1	AMU SENSE PCB ASSY
20	ELZ0015C	2	FERRITE CUBE FX-3854
21	MD00D21242	1	INSULATOR

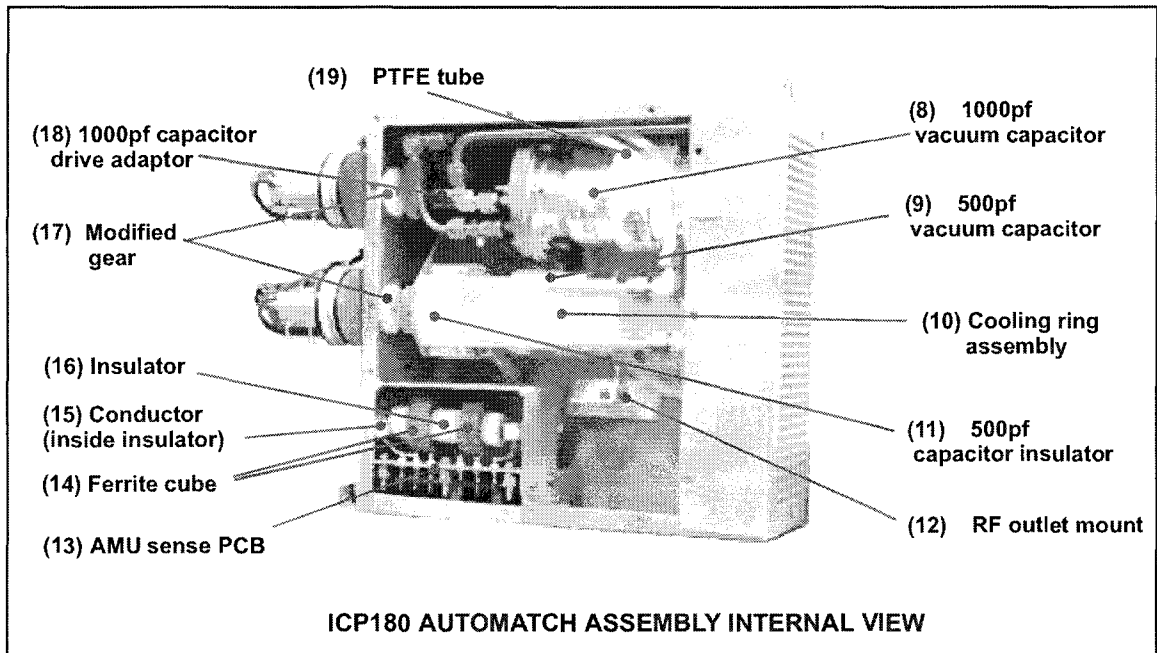
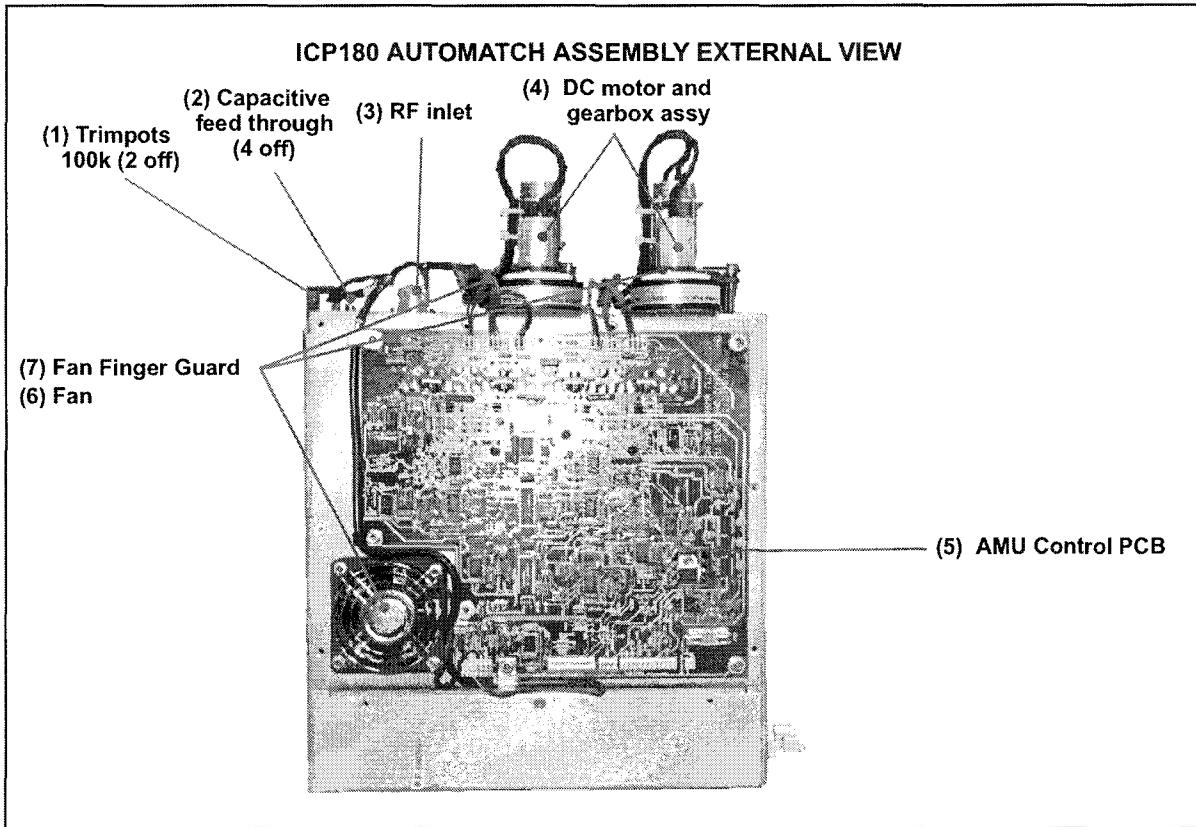

ICP180 FLOAT TOP ASSY. ALUMINA (100-6-56)

OIPT Part No.	Description
L/GEN/RFG/104	AE RFG3001 208V 3ph (BLACK BOX) RF GENERATOR
MA00Z23828	AUTOMATCH ASSEMBLY
MA00B23328	AMU CONTROL PANEL ASSY

6.2 Automatch assembly - vac cap (MA00Z23828)

Item	OIPT Part No.	Qty	Description
1	ERU0511	2	TRIMPOT 100K (3006) SERIES
2	ECC0001	4	CAPACITIVE FEED THRU 10,000 pf
3	EPP0005	1	SOCKET G15007H RR N CHAS. (RF INLET)
4	MA00D23738	2	MOTOR & GEARBOX ASSEMBLY
5	MA00Z20138	1	AMU CONTROL PCB ASSY
6	EFA0460C	3	FAN AXIAL 60 x 60 x 25.4 24 Vdc
7	EFA1062	3	FAN FINGER GUARD 60/62
8	L/CAP/VAR/110	1	VACUUM CAPACITOR 1000pf
9	L/CAP/VAR/106	1	VACUUM CAPACITOR 500pf
10	MA00D23772	1	COOLING RING ASSEMBLY
11	MD00D21224	1	500pf VACUUM CAPACITOR INSULATOR
12	MD00D19398	1	RF OUTLET MOUNT
13	MA00Z18209	1	AMU SENSE PCB ASSY
14	ELZ0015C	2	FERRITE CUBE FX-3854
15	MD00D21243	1	CONDUCTOR
16	MD00D21242	1	INSULATOR
17	MD00D22225	2	MODIFIED GEAR
18	MD00D21224	1	1000pf VACUUM CAPACITOR DRIVE ADAPTOR
19	R/TUB/PTF/030		¼" ODX x 3/16" ID PTFE TUBE

6.3 AMU control panel

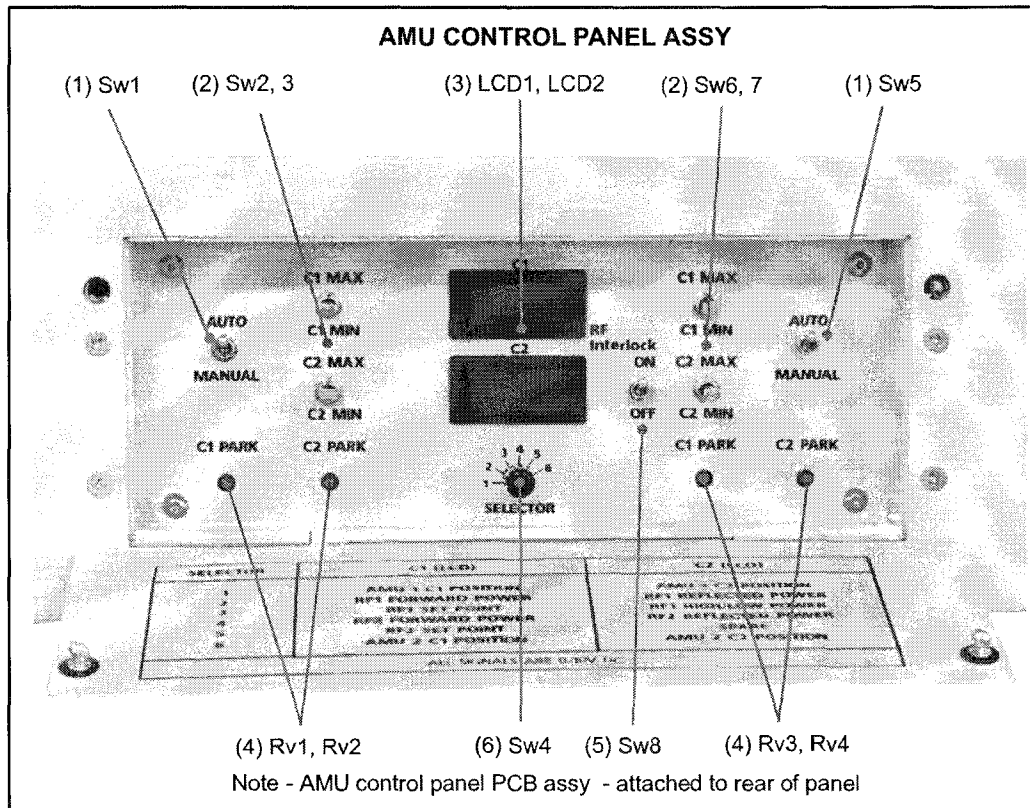

Item	OIPT Part No.	Qty	Description
1	EST3102C	2	SW1, SW5
2	EST1122C	4	SW2, SW3, SW6, SW7
3	EDM0200	2	LCD1, LCD2
4	ERU0417C	4	RV1, RV2, RV3, RV4
5	ESM0111	1	SW4
6	EST3204	1	SW8
7	MA00Z23250	1	OPT AMU CONTROL PANEL PCB ASSY

6.4 RF generators

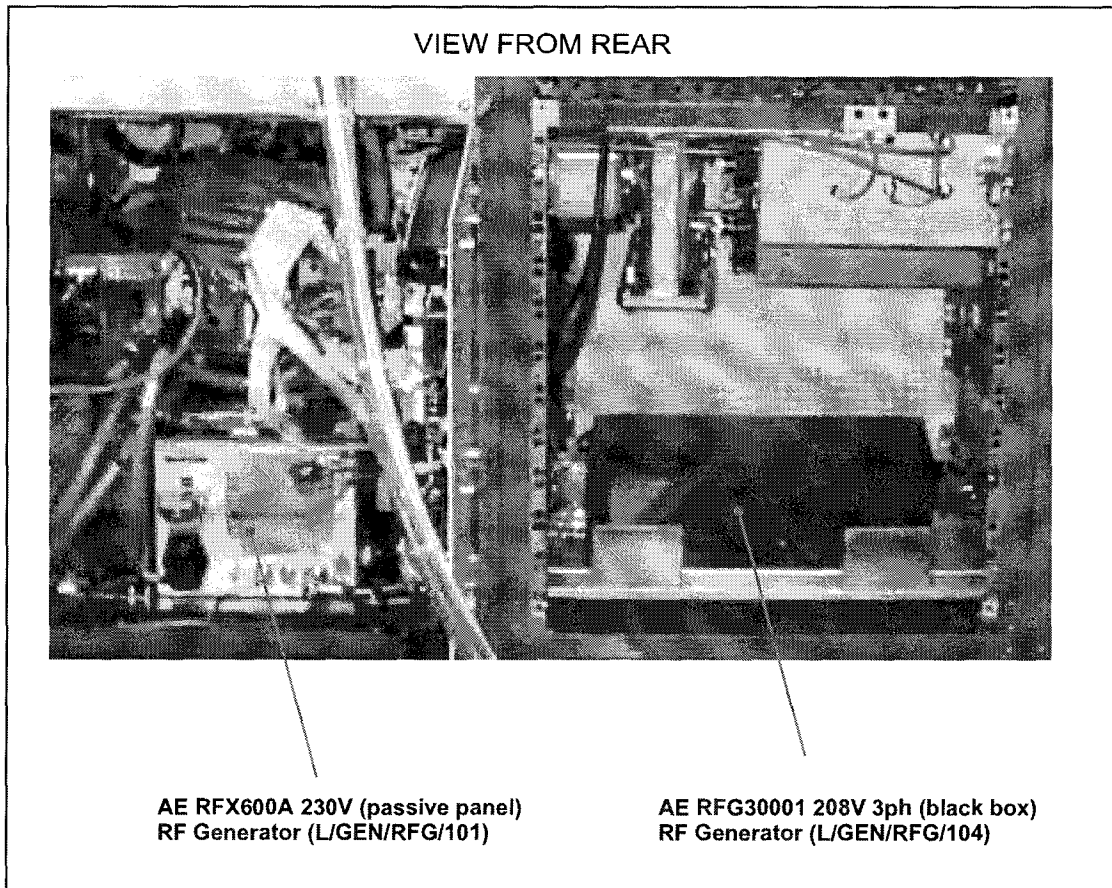

6.5 RF supplies and automatch option spares

Used on sales options: 81-6-15/1, 81-6-20/2, 81-6-61, 81-6-71, 81-6-80/3, 81-6-80/4, 100-6-30, 100-6-35.

OIPT Part No.	Qty	Description
MA00A23771	1	OPT VAC CAP AUTOMATCH UNIT
MA00Z20138	1	AMU CONTROL PCB ASSY
MA00Z18209	1	AMU SENSE PCB ASSY
L/CAP/VAR/110	1	1000pf VACUUM CAPACITOR
L/CAP/VAR/106	1	500pf VACUUM CAPACITOR
MA00D20107	1	OPT AMU DC BIAS COIL
G/SUN/GER/008	1	DC MOTOR GEARBOX 1250:1
G/SUN/GER/009	1	SERVO MOTOR 24 VDC RS.440-559
ERV0411	1	SERVO POTENTIOMETER 10K OHMS
ECC0001	1	CAPACITOR F/T 10,000 pf
ECC0290	2	CAPACITOR PADDING CER 20% 1 KV
MA00B23328	1	OPT AMU CONTROL PANEL ASSY
RIE 600W GEN + OPT AMU 200 PIPE (10-6-200V)		
L/GEN/RFG/101	1	AE RFX600A 230V (PASSIVE PANEL) RF GENERATOR

6.6 RF supplies and automatch (vac cap) ICP180 option spares

Used on 180 mm ICP systems from mid-end 2000

OIPT Part No.	Qty	Description
MA00A23828	1	AUTOMATCH ASSY. (VAC CAP) ICP180
MA00Z20138	1	AMU CONTROL PCB ASSY.
MA00Z18209	1	AMU SENSE PCB ASSY
L/CAP/VAR/110	1	VACUUM CAPACITOR 1000pf
L/CAP/VAR/106	1	VACUUM CAPACITOR 500pf
MA00D23738	2	MOTOR & GEARBOX ASSY. - Consists of G/SUN/GER/009/012/013
L/GEN/RFG/103	1	ICP GENERATOR - AE RFG 3001 208V 3 ph (BLACK BOX)

Section 7 - Vacuum Measurement

Section 7 - Vacuum Measurement	1
HEATED/UNHEATED 100 mT CAPACITIVE MANOMETER AND PENNING GAUGE (81-7-03/4)/(81-7-03/1)	2
7.1 100mT capacitive manometer and penning gauge.....	2
7.2 Vacuum measurement option spares.....	4

HEATED/UNHEATED 100 mT CAPACITIVE MANOMETER AND PENNING GAUGE (81-7-03/4)/(81-7-03/1)

7.1 100mT capacitive manometer and penning gauge

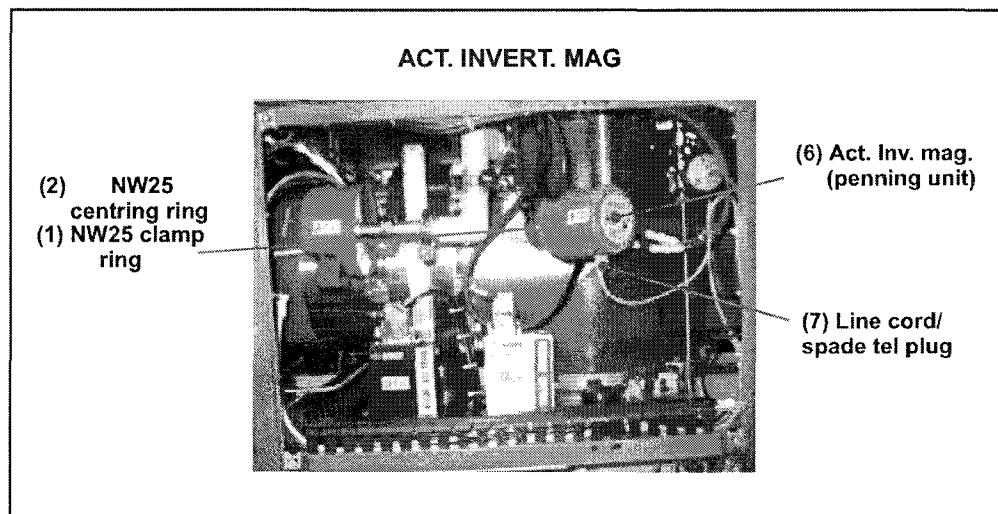
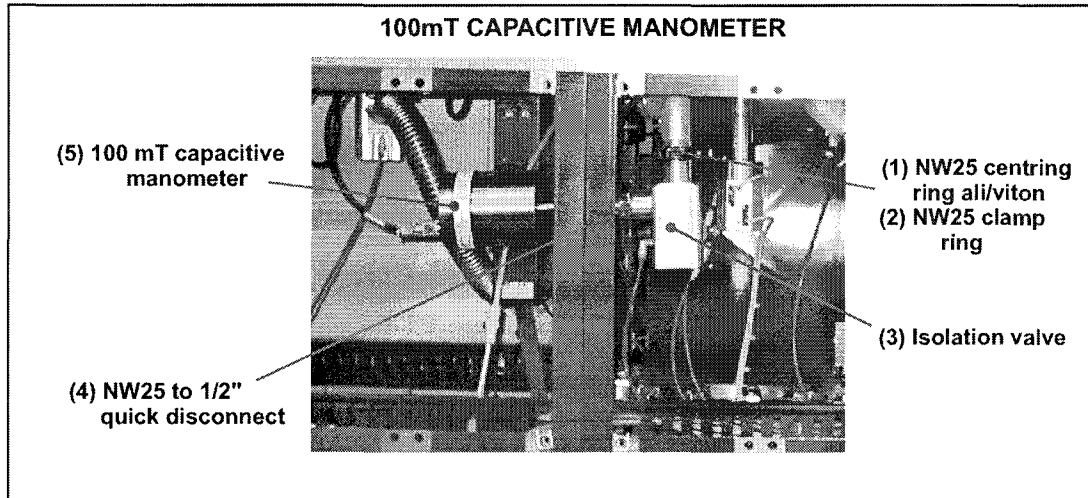

Item	OIPT Part No.	Qty	Description
1	G/VAC/SEL/025C	2	NW25 CENTRING RING ALI/VITON
2	G/VAC/CPL/025C	2	NW25 CLAMP RING
3	G/VAC/MLV/125	1	PV25PK ISOLATION VALVE
4	G/VAC/FIT/015C	1	NW25 TO ½" QUICK DISCONNECT
5	G/VAC/GGE/625	1	HEATED 100mT MKS CAPACITIVE MANOMETER 628B.1T-D-E-1-B - USED ON 81-7-03/4
5a	G/VAC/GGE/002	1	UNHEATED 100mT MKS CAPACITIVE MANOMETER - USED ON 81-7-03/1
6	G/VAC/GGE/004	1	ACT.INVERT.MAG.GGE.AIM-S-NW25 (PENNING UNIT)
7	EWM9307	1	LINE CORD PLG/SPADE TEL.PLUG

7.2 Vacuum measurement option spares















OIPT Part No.	Qty	Description
HEATED 100 mT CAPACITANCE MANOMETER + PENNING GAUGE (81-7-03/4)		
G/VAC/GGE/625	1	HEATED 100mT MKS CAPACITANCE MANOMETER 628B.IT-D-E-1-B - USED ON 81-7-03/4
G/VAC/GGE/002	1	UNHEATED 100mT MKS CAPACITANCE MANOMETER - USED ON 81-7-03/1
G/VAC/GGE/004	1	ACT INVERT MAG GGE AIM-V-NW25 (PENNING)
G/VAC/MLV/125	1	PV25PK ISOLATION VALVE
G/VAC/SEL/025	1	NW25 CENTERING RING

Section 8 - Pumping pipework

Section 8 - Pumping pipework	1
8.1 General	2
8.2 200mm pipework + 200 VAT APC (100-8-20).....	3
8.3 Pumping pipework option spares	6

8.1 General

A key to the symbols used to represent vacuum system components in the following illustrations is shown in the following key; where no symbol exists for a component, it is either labelled or can be identified from the associated table.

	Electromagnetically operated shut-off valve		Vacuum gauge head
	Pneumatically operated shut-off valve		Turbomolecular pump
	Manually operated variable-leak valve		Sliding vane rotary vacuum pump
	Gate valve		Cryogenic pump
	Butterfly valve e.g. APC		Reducer
	Vacuum flange / adapter		Flexible pipe
	Combination of flanges / adapters		Pressure relief valve

Key to vacuum schematic symbols

8.2 200mm pipework + 200 VAT APC (100-8-20)

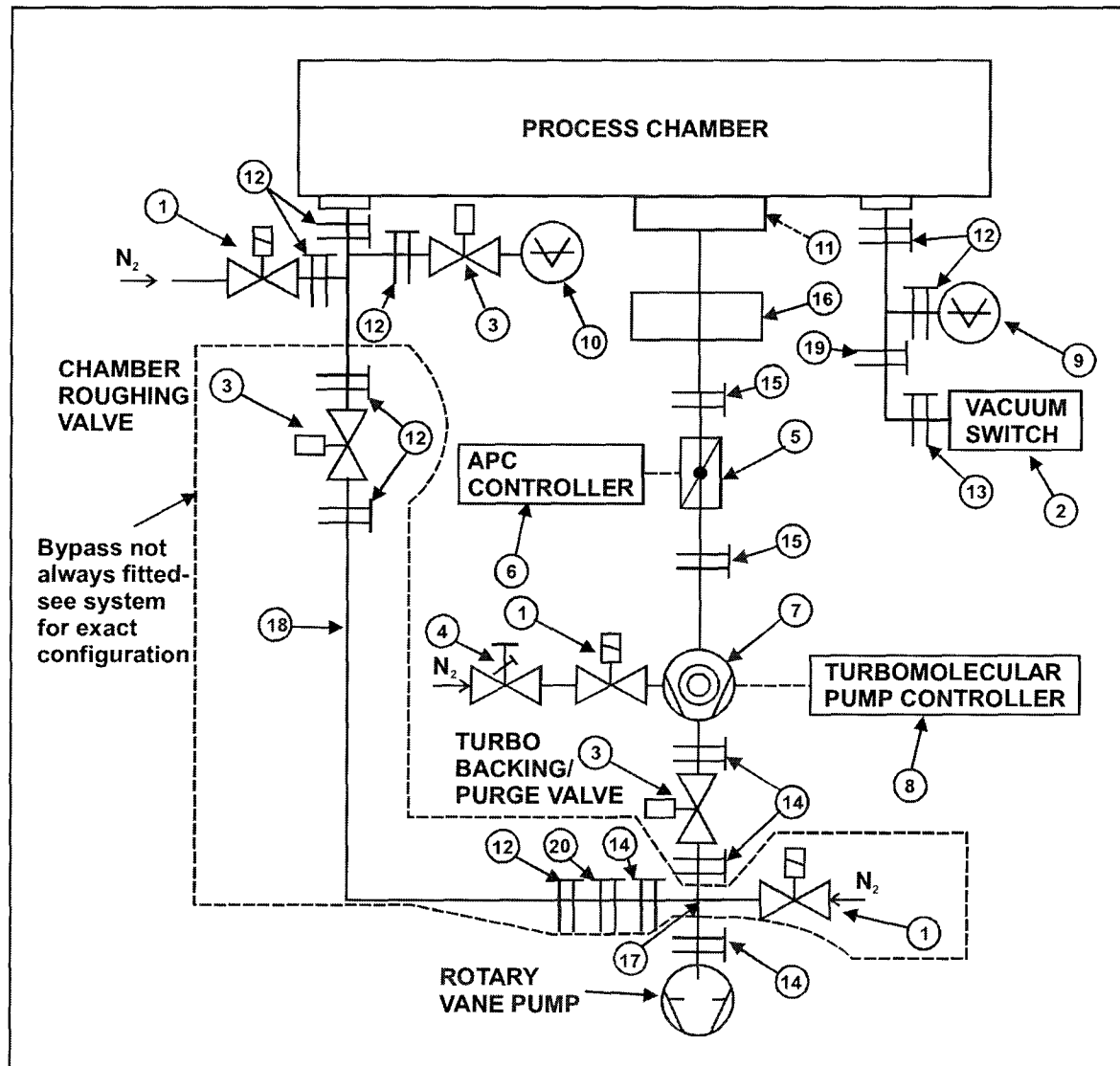

Item No. in illustration	OIPT Part Number	Description
1	GVV00012C	N ₂ VENT VALVES
2	G/VAC/SUN/032	EDWARDS VAC INTERLOCK SWITCH
3	G/VAC/MLV/125	PV25PK ISOLATION VALVE
4	M/MTR/MFM/003	MKS 100SCCM N ₂ FLOW METER SWAG
5	G/VAC/MLV/245	200ISO STEPGATE VALVE.64046-PE52
6	G/VAC/MLV/246	VAT APC CONTROLLER 641PM-16PM
7	G/VAC/PMP535	ALCATEL ATP900HPC TURBO ISO200
8	G/VAC/PMP/536	ALCATEL ACT100T TURBO CONTROLLER
9	G/VAC/GGE/004	ACT.INVERT.MAG.GGE.AIM-S-NW25 (PENNING UNIT)
10	G/VAC/GGE/625	100mT MKS CAPACITIVE MANOMETER 628B.1T-D-E-1-B
11	G/SEL/O-V/371	5.3 x 215.3 mm VITON 'O' RING BS 371
12	G/VAC/SEL/025C	NW25 CENTRING RING ALI/VITON
12a	G/VAC/CLP/025C	NW25 CLAMP RING
13	G/VAC/SEL/010C	NW10 CENTRING RING ALI/VITON
13a	G/VAC/CLP/010C	NW10 CLAMP RING
14	G/VAC/SEL/040C	NW40 CENTRING RING ALI/VITON
14a	G/VAC/CLP/040C	NW40 CLAMP RING
15	G/VAC/SEL/080	200ISO-K CENTRING RING ALI/VITON
16	G/VAC/FIT/280	ISO 200 - 200 TEE
17	G/VAC/FIT/240C	NW40 TEE
18	G/VAC/FLX/325	NW25 0.5M PIPE
19	G/VAC/FIT/004C	NW25/NW16 REDUCER C105-14-447
20	G/VAC/FIT/005C	NW40/NW25 REDUCER

EDWARDS VAC INTERLOCK SWITCH
G/VAC/SUN/032

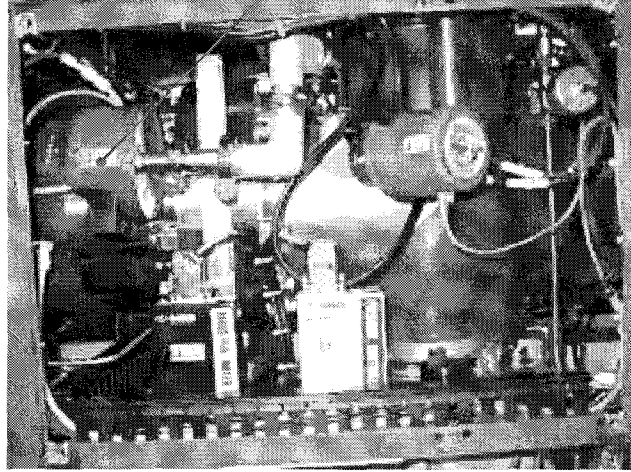

8.3 Pumping pipework option spares

OIPT Part No.	Qty	Description
200 mm VAT APC VACUUM KIT		
G/VAC/MLV/245	1	200 ISO STEPGATE VALVE 640046-PE52
G/VAC/MLV/246	1	VAT CONTROLLER 641PM-16PM
G/VAC/SEL/080	4	200 ISO CENTERING RING
G/VAC/SEL/025	2	NW25 CENTRING RING
G/VAC/SEL/040	2	NW40 CENTRING RING
G/VAC/SEL/010	2	NW10 CENTRING RING 08C10511395
G/VAC/SEL/068	1	DN 250 ISO-K CENTRING RING

Section 9 - Gas handling

Section 9 - Gas handling	1
9.1 6-line gas pod (81-9-51)	2
9.2 12-line gas pod (81-9-61)	4
9.3 Non-toxic gas line (81-9-11)	6
9.4 Toxic gas line (81-9-21)	7
9.5 Clean gas line with MFC (81-9-31)	8
9.6 Clean gas line with rotameter (81-9-07)	9
9.7 Gas handling option spares	10

9.1 6-line gas pod (81-9-51)

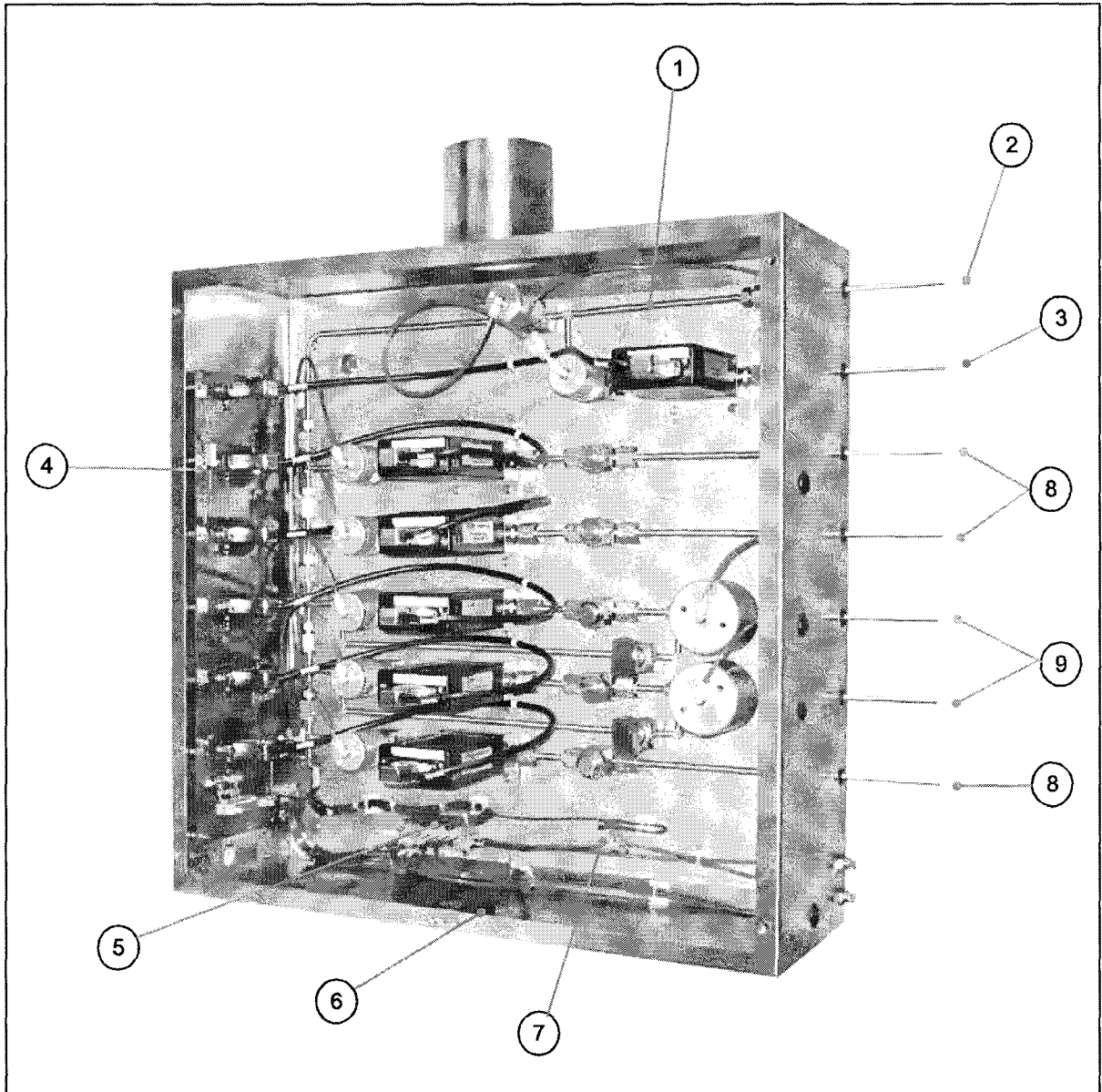

Item No.	OIPT Part No.	Qty	Description
1	MA81D15070	1	MANIFOLD GAS OUT PIPE
2	MA81D14783	1	GAS CONNECTION LINE
3	81-9-31	1	CLEAN GAS LINE (SEE SUB-SECTION 9.5)
4	MA81Z16003	1	GAS POD CHAMBER A OR B INTERFACE PCB
5	G/AIR/VLV/506	1	6 WAY SMC ASSY. SPASBR06
6	ESZ9102	1	DOOR INTERLOCK MICRO-SW SPDT
7	G/AIR/VLV/501	1	SINGLE SMC ASSY. SPASBR01
8	81-9-11	1	NON-TOXIC GAS LINE (SEE SUB-SECTION 9.3)
9	81-9-21	1	TOXIC GAS LINE (SEE SUB-SECTION 9.4)

9.2 12-line gas pod (81-9-61)

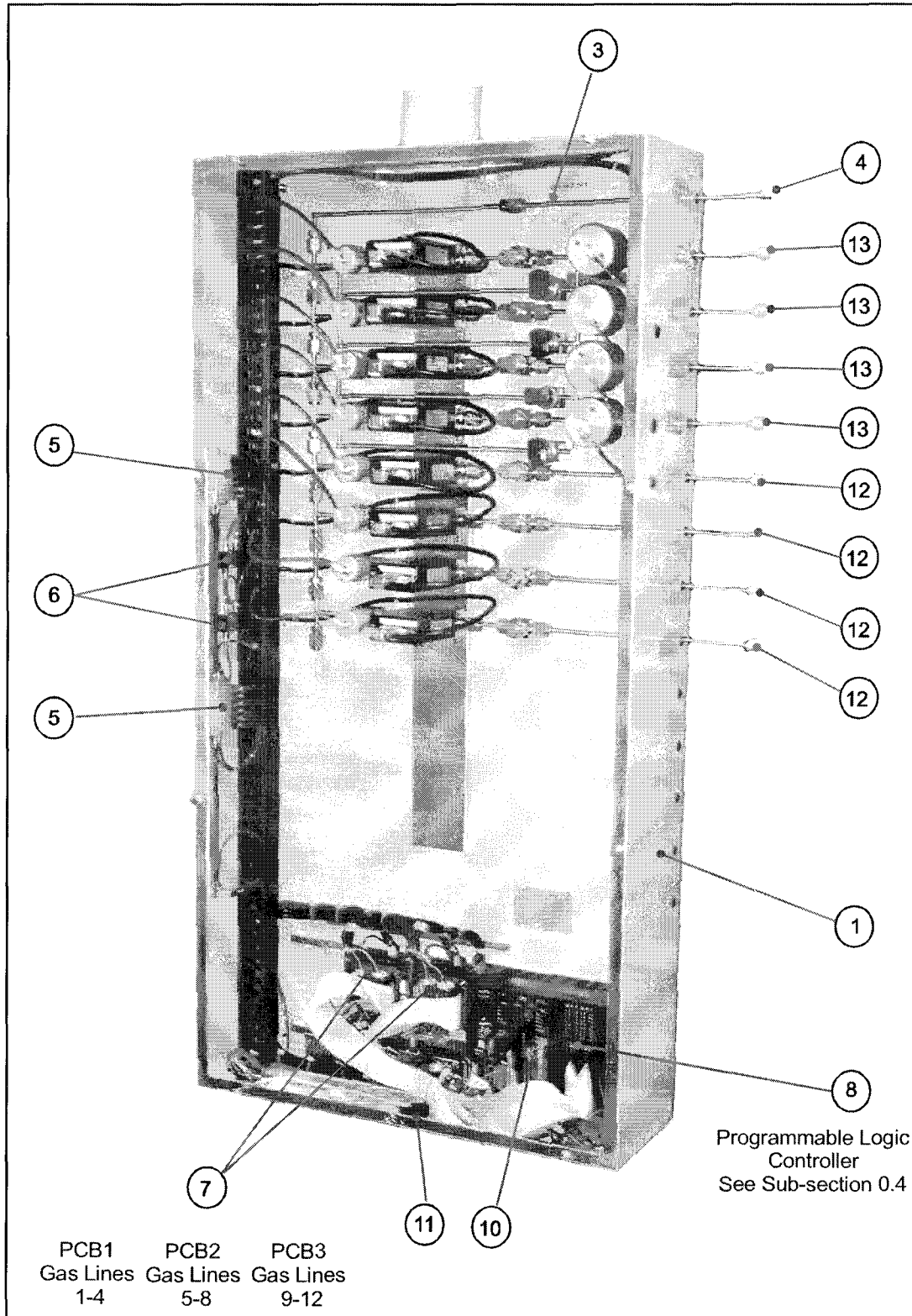

Item	OIPT Part No.	Qty	Description
1	MD81A22487	1	GAS POD BOX
2	MD31B18526	1	GAS POD LID
3	MA81D14783	1	GAS CONNECTION LINE
4	MA81D15070	1	MANIFOLD GAS OUT PIPE
5	G/AIR/VLV/506	2	6 WAY SMC ASSY.SPASBR10
6	G/AIR/VLV/501	2	SINGLE SMC ASSEMBLY. SPASBR01
7	MA31Z18421	3	300 PLUS GASES PCB2 ASSY
8	EXP0701	1	B&R MINICONTROLLER
	EXP0730	1	B&R DIGITAL MODULE 16 I/P
	EXP0725	1	B&R ANALOGUE MODULE.4
	EXP0750	3	B&R ARCNET INTERF. EE32-0
10	MA81Z16005	3	PLC INTERFACE PCB
11	ESZ9102	1	DOOR INTERLOCK MICRO-SW SPDT
12	81-9-11		NON-TOXIC GAS LINE (SEE SUB-SECTION 9.3)
13	81-9-21		TOXIC GAS LINE (SEE SUB-SECTION 9.4)
14	81-9-31	1	CLEAN GAS LINE (SEE SUB-SECTION 9.5)

Note - For PLC components, see Sub-section 0.4.

9.3 Non-toxic gas line (81-9-11)

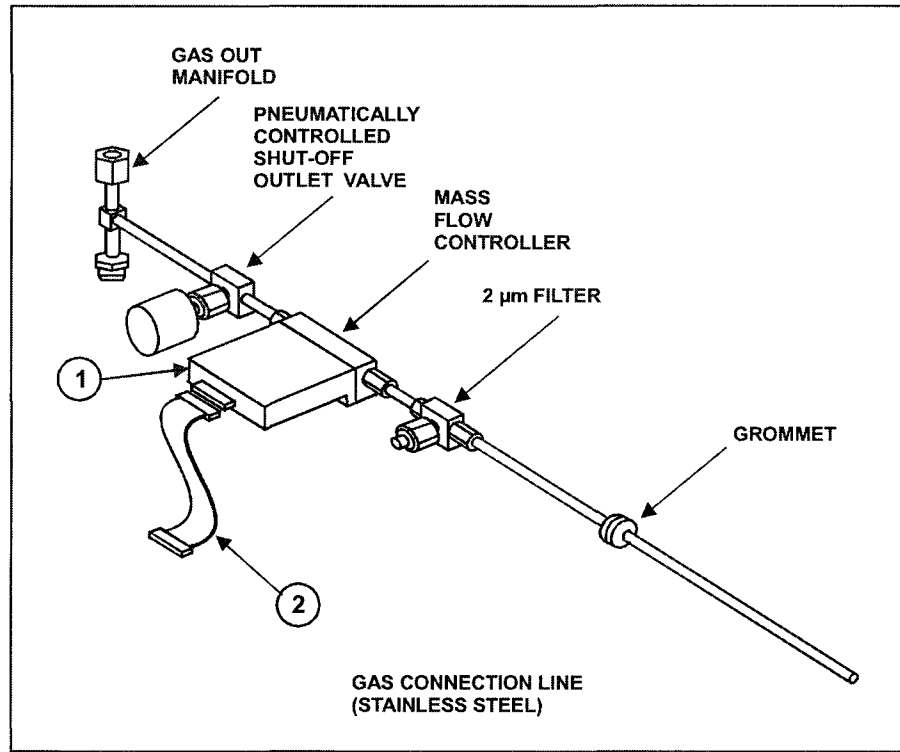

Item No. in Illustration	Part Number	Description
	MA81D15065	NON-TOXIC GAS KIT TYPE 'A' (all welded pipework including filter and control valve but excluding MFC and MFC cable)
	G/GAS/FIT/614C	1/4 GASKET. RETAIN SS4VCR2GR (USED IN ALL VCR FITTINGS)
1	*	MASS FLOW CONTROLLER
2	MA00Z21746	MKS MASS FLOW CABLE ASSY

* Mass Flow Controllers are not supplied with the gas line, they vary in type according to each customer's requirement. Please quote the part number on the unit if spares are required.

9.4 Toxic gas line (81-9-21)

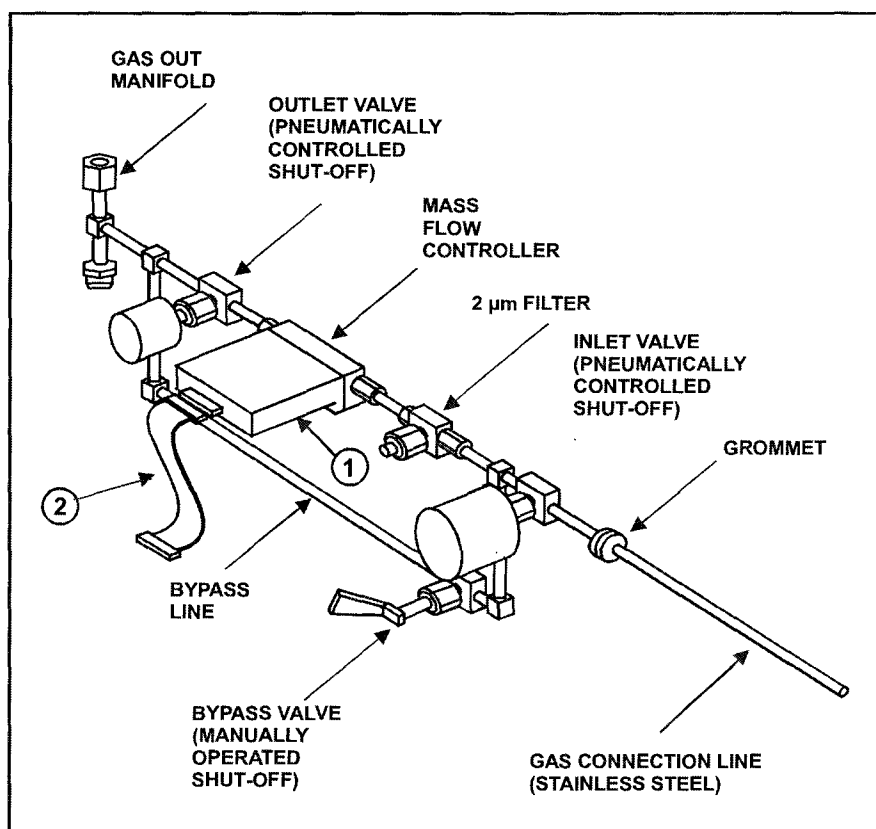

Item No. in Illustration	Part Number	Description
	MA81B15064	AUTO TOXIC GAS LINE SNGL TYPE 'C' (all welded pipework including filter and valves but excluding MFC and MFC cable)
	G/GAS/FIT/614C	1/4 GASKET. RETAIN SS4VCR2GR (USED IN ALL VCR FITTINGS)
1	*	MASS FLOW CONTROLLER
2	MA00Z21746	MKS MASS FLOW CABLE ASSY

* Mass Flow Controllers are not supplied with the gas line, they vary in type according to each customer's requirement. Please quote the part number on the unit if spares are required.

9.5 Clean gas line with MFC (81-9-31)

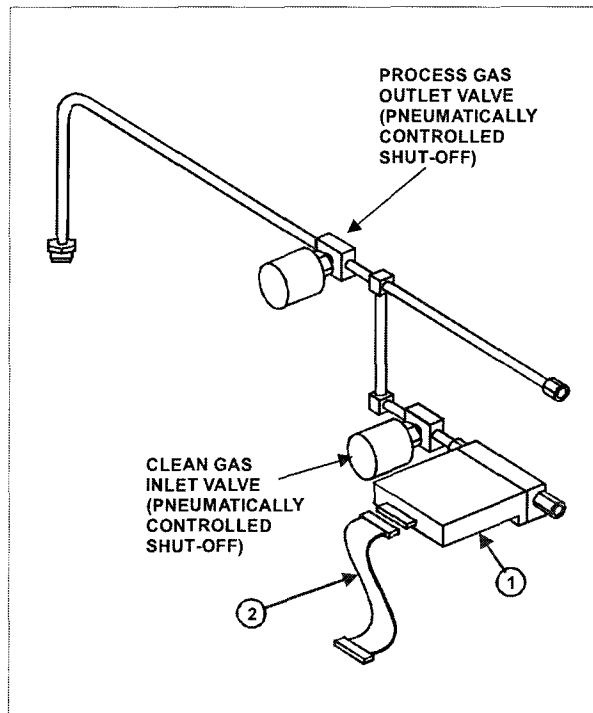

Item No. in Illustration	Part Number	Description
	MA81C15916	CLEAN GAS LINE (MFC CONTROLLED) (all welded pipework including valves but excluding MFC and MFC cable)
	G/GAS/FIT/614C	1/4 GASKET. RETAIN SS4VCR2GR (USED IN ALL VCR FITTINGS)
1	*	MASS FLOW CONTROLLER
2	MA00Z21746	MKS MASS FLOW CABLE ASSY

* Mass Flow Controllers are not supplied with the gas line, they vary in type according to each customer's requirement. Please quote the part number on the unit if spares are required.

9.6 Clean gas line with rotameter (81-9-07)

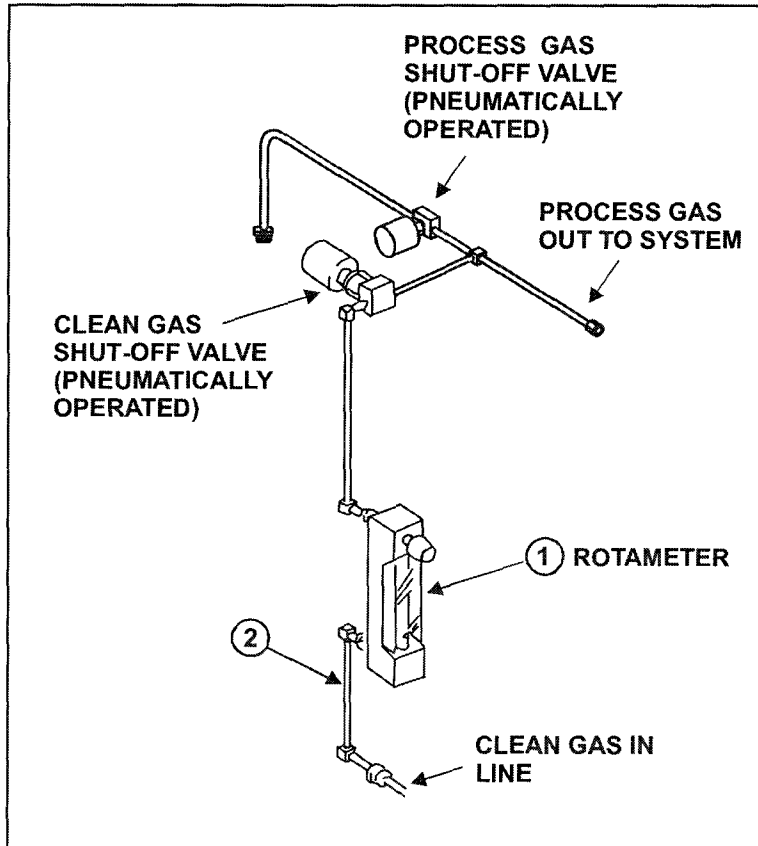

Item No. in Illustration	Part Number	Description
	MA81B15081	CLEAN GAS LINE (ROTAMETER) (all welded pipework including valves but excluding rotameter)
	G/GAS/FIT/614C	1/4 GASKET. RETAIN SS4VCR2GR (USED IN ALL VCR FITTINGS)
1	G/GAS/ROT/800	ROTAMETER 800 CCM F65-SAHR3-A125-7SS
2	MA81D14784	INLET PIPE (ROTAMETER)

9.7 Gas handling option spares

OIPT Part No.	Qty	Description
81-9-51 - Externally mounted gas pod for up to six MFC lines + one rotameter or MFC control line		
MA81Z16003	1	GAS POD CHAMBER A or B PCB
G/AIR/VLV/506	1	6 WAY SMC ASSEMBLY SPASBR06
ESZ9102	1	DOOR INTERLOCK MICRO-SW SPDT
G/AIR/VLV/501	1	SINGLE SMC ASSEMBLY SPASBR01
G/GAS/FIT/614	1	¼ RETAINING GASKET
81-9-11	1	Non-toxic gas line excluding mass flow controller
G/GAS/FIT/614	10	¼ RETAINING GASKET
81-9-21	1	Toxic gas line with MFC bypass, excluding mass flow controller
G/GAS/FIT/614	10	¼ RETAINING GASKET

Section 10 - Wafer handling options, load locks and robotics

Section 10 - Wafer handling options, load locks and robotics	1
10.1 Loadlock (100-10-05C).....	2
10.2 Wafer handling option spares.....	5

10.1 Automatic load lock (100-10-05C)

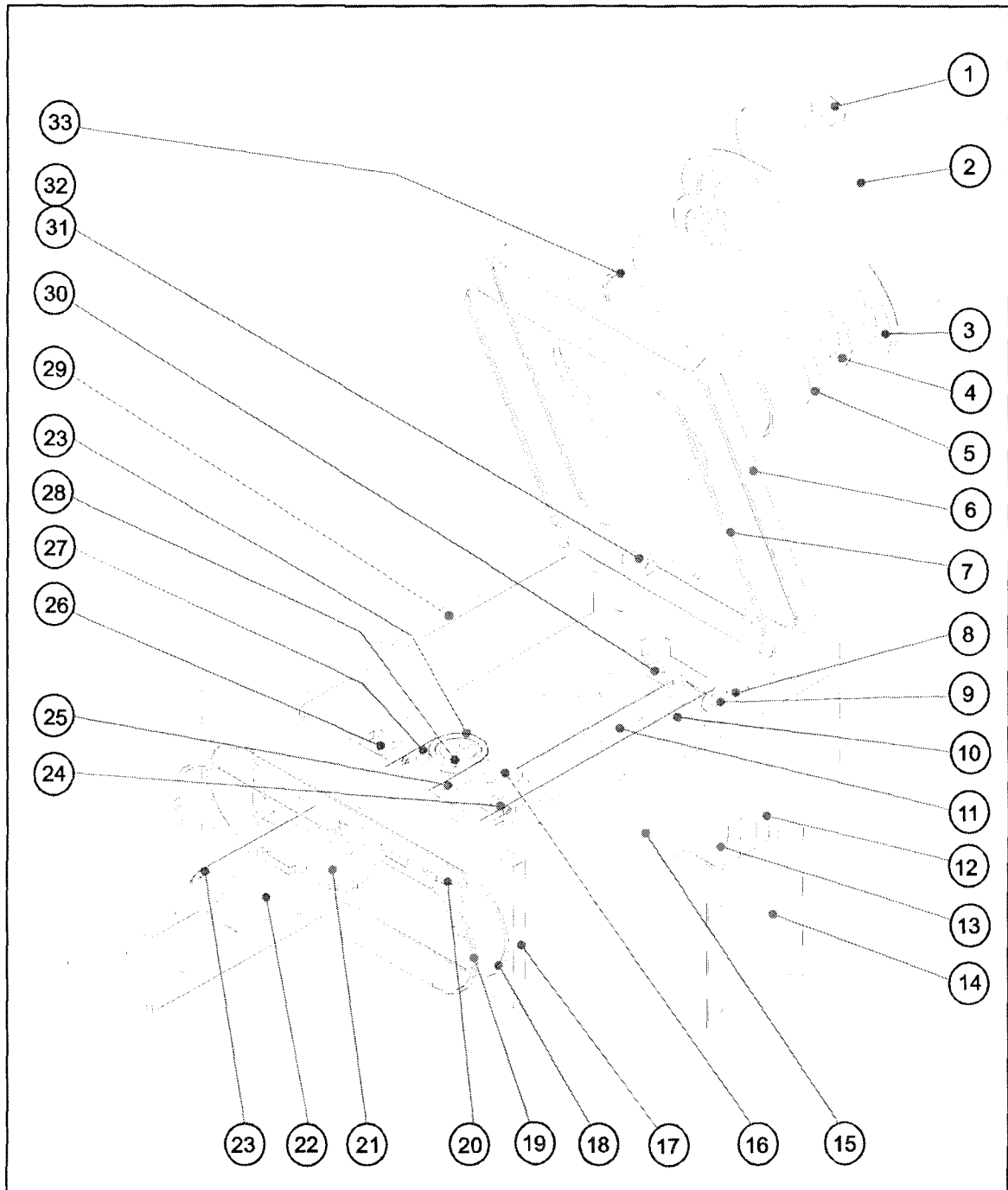

Item	OIPT Part No.	Qty	Description
	MA00A20102	1	LOADLOCK ASSY. 46 x 236 mm VAT VALVE
1	G/SUN/CAB/942	1	HAND KNOB (M6) DIA. 30 mm
2	MD00D20785	1	LOADLOCK PROTECTIVE WINDOW
3	MD00C17683	1	VIEW PORT CLAMP PLATE
4	MD90D12788	1	WINDOW GASKET
5	MD90D12789	1	WINDOW GLASS
6	MD00A21658	1	LOADLOCK HINGED LID
7	G/SEL/O-V/279C	1	3.5 x 329.8 mm VITON 'O' RING BS279C
8	G/VAC/FIT/927	1	ROTARY FEEDTHRO. (8 mm SHAFT)
9	MD00C17699	1	DRIVE PULLEY
10	G/SUN/BEL/013	1	S/S BELT 6.35W x 0.075THK x 731LG
11	G/SUN/BRG/904	1	MINIATURE LM GUIDE TYPE HRW 14
12	MD00D20183	4	PILLAR
13	MD91C17754	1	SUPPORT PLATE
14	MD00D180027	1	LOADLOCK PCB MOUNT
15	MD00A20103	1	LOADLOCK CHAMBER 46 x 236 mm VAT VALVE
16	G/SUN/BRG/903	1	MINIATURE LM GUIDE TYPE HRW 12
17	MD00B20814	1	LOADLOCK/VALVE INTERFACE 2-RINGS
18	G/SEL/O-V/263C	1	3.5 x 196.4 mm VITON 'O' RING BS263
19	G/SEL/O-V/269C	1	3.5 x 221.85 mm VITON 'O' RING 200-269
20	MD00D17695	1	LOWER FRONT PULLEY MOUNT
21	MD00D20146	1	END EFFECTOR PLATE 2.2. Kg S/ST
22	MD00C20145	1	END EFFECTOR 2.2. Kg S/ST RATE
23	MD00D17698	3	DRIVEN PULLEY
24	MD00D17744	1	LOWER CARRIAGE BELT CLAMP
25	MD00C20253	1	UPPER RAIL SUPPORT
26	MD00D17693	1	UPPER REAR PULLY MOUNT
27	G/SUN/BEL/012	1	S/S BELT 6.35W x 0.075THK x 641LG
28	MD00D17696	3	PULLEY BEARING CLAMP
29	MD00B21657	1	LOADLOCK TOP COVER
30	MD00D17701	1	LOWER CARRIAGE END STOP
31	MD00D23696	2	HINGE BLOCK
32	MD00C23711	2	LID - HINGE PIN FIXING
33	G/SEL/O-V/260C	1	3.5 x 164.7 mm VITON 'O' RING BS260C
*	MA00Z17834	1	LOADLOCK MOTOR CONTROL ASSEMBLY
*	G/SUN/GER/009C	1	SERVO MOTOR 24VDC RS.718-981
*	EMM0025	1	PRECISION DC M/GEARBOX 640:1
*	G/VAC/GGE//005	1	ACT. PIRANI GGE APG-L-NW16
*	G/VAC/GGE/004	1	ACT. INVERT MAG GGE AIM-V-NW25
	G/SEL/O-V/280C	1	3.5 x 355.2 mm VITON 'O' RING BS280 - NOT SHOWN - FITS BETWEEN ITEMS 15 AND 28
	G/SEL/O-V/264C	1	3.5. x 190.1 mm VITON 'O' RING BS264 - NOT SHOWN - FITS BETWEEN ITEMS 15 AND 17
	G/SUN/BRG/050	3	4 PNT CONT'T BRG 1" 'ID x 1.375' O/D - NOT SHOWN - FITS ON EACH ITEM 22
	MD00D17674	1	10 PIN SEAL BODY - NOT SHOWN
	MD00D17702	1	UPPER CARRIAGE END STOP - NOT SHOWN
	MD00D17745	1	UPPER CARRIAGE BELT CLAMP - NOT SHOWN
	ESZ9017	1	MICROSWITCH 331-405 - NOT SHOWN
	EIQ0055C	1	OPTO SENSOR SLOTTED TRW - NOT SHOWN
	MD00D18027	1	MICROSWITCH PLUNGER - NOT SHOWN
	MD00D18042	1	MICROSWITCH ACTUATOR - NOT SHOWN
	MD91D17505	4	LOCATION PIN - NOT SHOWN
*			SEE PHOTOGRAPH ON FOLLOWING PAGE

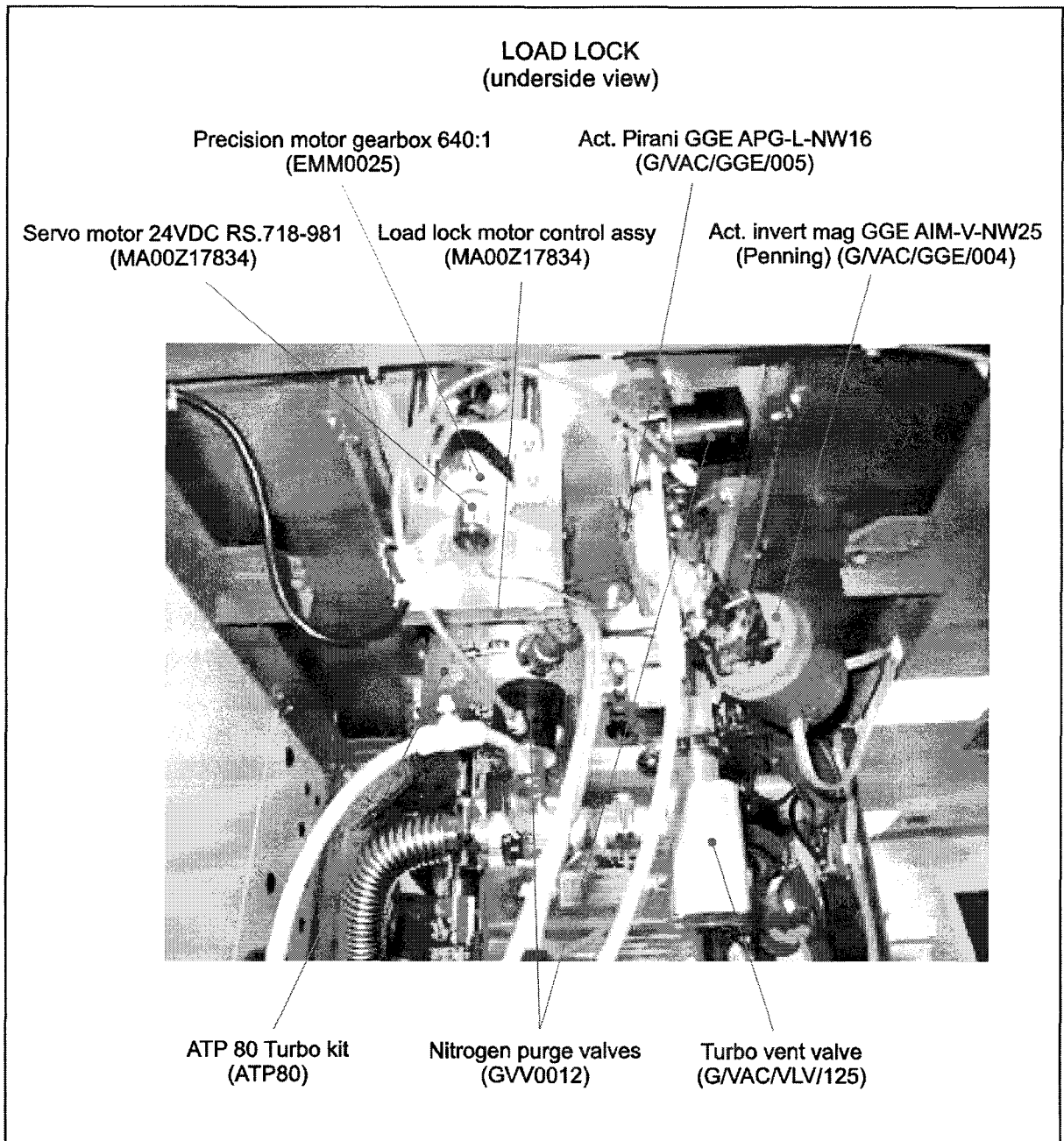

10.2 Wafer handling option spares

OIPT Part No.	Qty	Description
COMMON SPARES, SINGLE WAFER AUTOMATIC INSERTION LOAD LOCK FOR USE WITH ISOLATED PROCESS CHAMBER, INCLUDING SUPPORT FRAME AND ACTIVE PIRANI GAUGE (100-10-5xxx)		
G/SUN/BEL/012	1	S/S BELT 6.35W x 0.075THK x 641LG
ESZ9107	1	MICRO SWITCH 331-405
G/VAC/FIT/927	1	ROTARY FEEDTHROUGH (8 mm SHAFT)
G/SUN/GER/009	1	SERVO MOTOR 24 VDC
EMM0025	1	PRECISION DC M/GEAR
MA00Z17834	1	LOADLOCK MOTOR CONTROLLER PCB
G/SUN/BEL/013	1	S/S BELT 6.35W x 0.075THK x 731LG
EIQ055	1	OPTO SENSOR SLOTTED
G/VAC/GGE/005	1	ACTIVE PIRANI GAUGE APG
G/SUN/BRG/050	1	4 PNT CONT'T BRG 1" I/D x 1.375" O/D
AS ABOVE WITH LARGE MESC VALVE (100-10-05C)		
G/SUN/BRG/903	1	MINIATURE LM GUIDE BEARING TYPE HRW12
G/SUN/BRG/904	1	MINIATURE LM GUIDE BEARING TYPE HRW14
G/SEL/O-V/269	1	3.5 x 221.85 mm VITON 'O' RING 200-269
PM KIT LOADLOCK HANDLER - STANDARD QUARTZ CLAMP TOOLING (100-10-05CS)		
MD91B22328SP	1	4" DIA WAFER CLAMP QUARTZ
MD91B22277SP	1	3" DIA WAFER CLAMP QUARTZ
MD91B22327SP	1	2" DIA WAFER CLAMP QUARTZ
MD91B24693SP	1	5" DIA WAFER CLAMP QUARTZ
MD91B22329SP	1	6" DIA WAFER CLAMP QUARTZ
MD91B23036SP	1	8" DIA WAFER CLAMP QUARTZ

NOTES:

Section 11 - Spares

Section 11 - Spares	1
11.1 Standard spare parts kits	2
11.2 Common system 100 base unit standard spares kit.....	3
11.3 ICP180 additional parts kit	3
11.4 Single wafer OIPT Loadlock spares kit	4

11.1 Standard spare parts kits

This section covers a commonly sold consumable parts list (100-S-PM ICP 180) for the **Plasmalab** System 100 (ICP180) exchanged as part of a Planned Annual Maintenance visit.

11.2 Common system 100 base unit standard spares kit

A kit containing recommended parts for a System 100 base module including window components, table components, general fixings etc.

Spares kit Part Number 100-S-CMP

OIPT Part No.	Qty	Description
G/SEL/O-V/384	1	5.3 mm x 380.37 mm VITON 'O' RING 200-384 (Top electrode lid - chamber seal)
G/SEL/O-V/211	1	3.5 mm x 20.2 mm VITON 'O' RING BS211
G/SEL/O-V/829	1	3.5 mm x 47.6 mm VITON 'O' RING BS829 (Table feedthrough 'O' ring)
G/SEL/O-V/146	1	2.6 mm x 66.3 mm VITON 'O' RING BS146 (Table feedthrough 'O' ring)
G/SEL/O-V/362	2	5.34 mm x 158.12 mm VITON 'O' RING BS362 (A - Pump down pipe to baseplate) (B - Table to baseplate)
G/VAC/SEL/040C	1	NW40 CENTERING RING ALI/VITON
G/GAS/FIT/614C	1	¼ RETAINING GASKET (GIM vcr gasket)
M/0651D/01	1	WINDOW GLASS (6 MM PYREX)
M/4175D/01	1	WINDOW GASKET
MA00D14711	1	NW40 CENTERING RING MOD (Viewport seal)
MD81D14211	1	UV/RF FILTER (Viewport filter)
MD81D14110	1	COMPRESSION RING (Table FT seal)
MD81C14107	1	TABLE FEEDTHROUGH (Table FT)
G/FIX/S32/630	4	M6 x 30 mm S/S CAPHEAD SCREW (Fixing 100 RIE)
G/FIX/S32/616	4	M6 x 16 mm S/S CAPHEAD SCREW (Fixing 100 RIE)
G/FIX/S54/516	4	M5 x 16 mm S/S CSK HEAD SCREW (Fixing 100 RIE)
G/FIX/S21/930	4	M10 x 30 mm HEX HD S/S SCREW (Fixing 100 PECVD)
G/FIX/S32/630	4	M6 x 30 mm S/S CAPHEAD SCREW (Fixing 100 PECVD)
G/FIX/S32/640	4	M6 x 40 mm S/S CAPHEAD SCREW (Fixing 100 PECVD)
G/FIX/S21/520	4	M5 x 20 mm HEX HD S/S SCREW (Fixing 100 PECVD)
G/FIX/S31/508	2	M5 x 8 mm CAPHEAD SKT SCREW (Fixing 100 PECVD)
G/FIX/S35/535	4	M5 x 35 mm S/S CAPHEAD SCREW (Fixing 100 PECVD)

11.3 ICP180 additional parts kit

The list below contains additional spares that are limited to ICP180 machines:

Spares kit Part Number 100-S-180C - Ceramic

OIPT Part No.	Qty	Description
G/SEL/O-K/219	1	3.53 mm x 32.9 mm KALREZ 'O' RING BS219 (Gas inlet manifold)
G/SEL/O-K/235	1	3.53 mm x 79.0 mm KALREZ 'O' RING BS235 (Gas inlet manifold)
G/SEL/O-K/117	1	2.62 mm x 20.3 mm KALREZ 'O' RING BS117 (Gas inlet manifold)
G/SEL/O-K/264	2	3.53 mm x 190.1 mm KALREZ 'O' RING BS264 (Main ICP tube seal)
G/VAC/FIT/039SP	1	VIEWPORT NW25 GLASS VP-NW-25 (Viewport)
G/VAC/SEL/025CSP	1	NW25 CENTERING RING (Viewport)
G/VAC/SEL/015	1	NW16 CENTERING RING ALUMINIUM (Top plate)
MD81D15847	1	PTFE RING (Gas inlet manifold)
MD00C18542SP	1	ALUMINA TUBE - ICP SOURCE (Main ICP Process tube)

11.4 Single wafer OIPT load lock spares kit

The kit in the table below applies if a Single Wafer OIPT load lock is attached and consists of the following components:

Spares kit Part Number 100-10-05CS

OIPT Part No.	Qty	Description
MD90D12788	1	WINDOW GASKET (Single wafer OIPT loadlock)
G/SEL/O-VI/280C	1	3.5 mm x 355.2 mm VITON 'O' RING BS280 (Single wafer OIPT loadlock)
G/SEL/O-VI/260C	1	3.5 mm x164.7 mm VITON 'O' RING 200-260 (Single wafer OIPT loadlock)
G/VAC/SEL/015C	1	NW16 CENT. RING ALI/VITON (Single wafer OIPT loadlock)
G/SEL/O-VI/015	1	1.8 mm x13.99 mm VITON 'O' RING BS015 (Single wafer OIPT loadlock)
G/SEL/O-VI/263C	1	3.5 mm x 196.4 mm VITON 'O' RING BS263 (Single wafer OIPT loadlock)
G/SEL/O-VI/269C	1	3.5 mm x 221.85 mm VITON 'O' RING 200-269 (Single wafer OIPT loadlock)
G/SEL/O-VI/279C	1	3.5 mm x 329.8 mm VITON 'O' RING BS279 (Single wafer OIPT loadlock)

Section 12 - Accessories

Section 12 - Accessories	1
12.1 Heaters/chillers	2
12.2 Heater/chiller option spares	2
12.3 End point detectors.....	3
12.3.1 Verity EP200 end point kit (100-12-72/01)	3
12.3.2 Verity EP200 optional spares	3
12.3.3 Sofie integrated laser end point kit (81-12-86)	4
12.3.4 Sofie integrated laser optional spares	4

12.1 Heaters/chillers

Heater chiller various options

OIPT Part No.	Description
81-12-18	CU500 HEATER CHILLER 240V 50Hz
81-12-18/1	CU500 HEATER CHILLER 208V 60Hz
81-12-19	CU500 DIGITAL HEATER/CHILLER 240V 50Hz
81-12-19/1	CU500 DIGITAL HEATER/CHILLER 208V 60Hz
81-3-18/1	CU500 HEATER CHILLER 208V 60Hz
G/WTR/SUN/520	CU500 818S DIGITAL + FILTER KIT 240V 50Hz
G/WTR/SUN/521	CU500 818S DIGITAL + FILTER KIT 208V 60Hz
G/WTR/SUN/550	CU500 HEATER/CHILLER (+ACU006)
G/WTR/SUN/551	CU500 FAN MOTOR PT. No. 500-5

12.2 Heater/chiller option spares

OIPT Part No.	Qty	Description
G/WTR/SUN/502	1	PUMP HEAD FOR CU500
G/WTR/SUN/503	1	PUMP MOTOR FOR CU500
G/WTR/SUN/007		CORROSION INHIBITOR 3 x 5 LTR PACK
G/VAC/OIL/905	1	VAC GREASE SILICONE
G/WTR/SUN/801	1	WATER FILTER UNIT MCY4463EG

12.3 End point detectors

12.3.1 Verity EP200 end point kit (100-12-72/01)

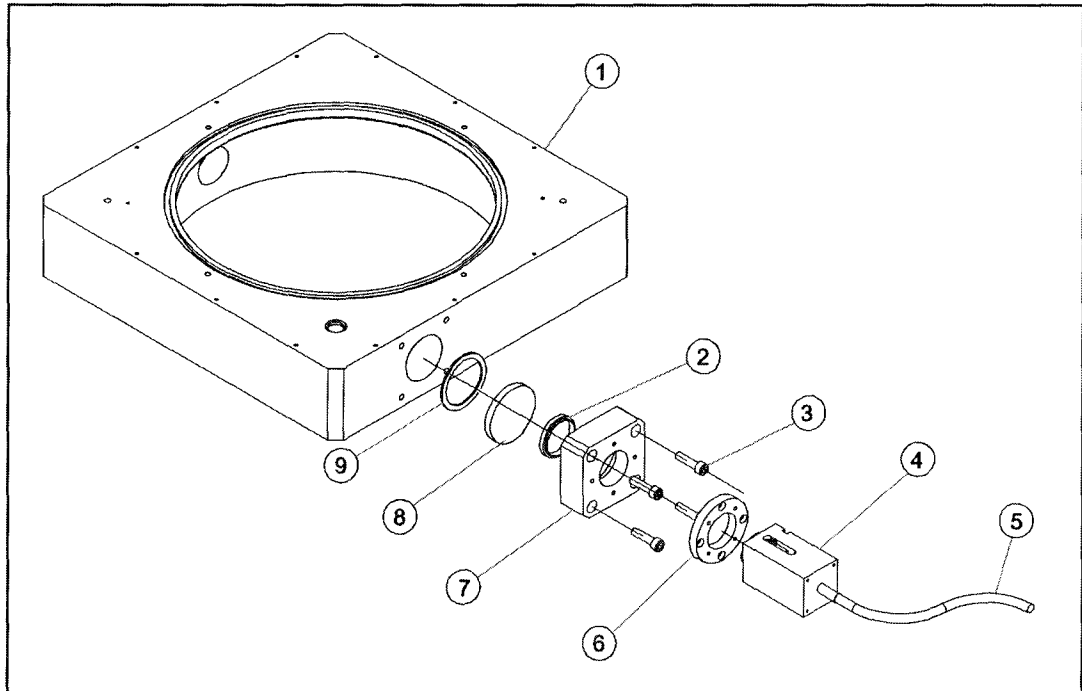

Item	Part No.	Description
1		CHAMBER
2	MA90D13116	CENTRING RING
3	G/FIXS32625	M6 x 25 mm S/S CAPHEAD SCREW
4	G/SUN/END/021	VERITY EP200SCR ADAPTOR
5	G/SUN/END/023	VERITY SL-UV10 FIBRE OPTIC 1M
6	MD91D17811	END POINT ADAPTOR RING
7	MD91C17809	END POINT ADAPTOR FLANGE (EP200)
8	M/4078D/01	WINDOW GLASS (6 mm QUARTZ)
9	M/4175D/01	WINDOW GASKET
	G/SUN/END/022	VERITY LC10 LIGHT COUPLER (LOCATED IN ADAPTOR - ITEM 5)
	G/SUN/END/020	VERITY EP200MD 200 mm MON/DET (LOCATED ON FRONT PANEL - ABOVE RF GENERATOR)

12.3.2 Verity EP200 optional spares

OIPT Part No.	Qty	Description
MA90D13116	1	CENTRING RING
M/4175D/01	1	WINDOW GASKET
M/4078D/01	1	WINDOW GLASS (6 mm QUARTZ)

12.3.3 Sofie integrated laser end point kit (81-12-86)

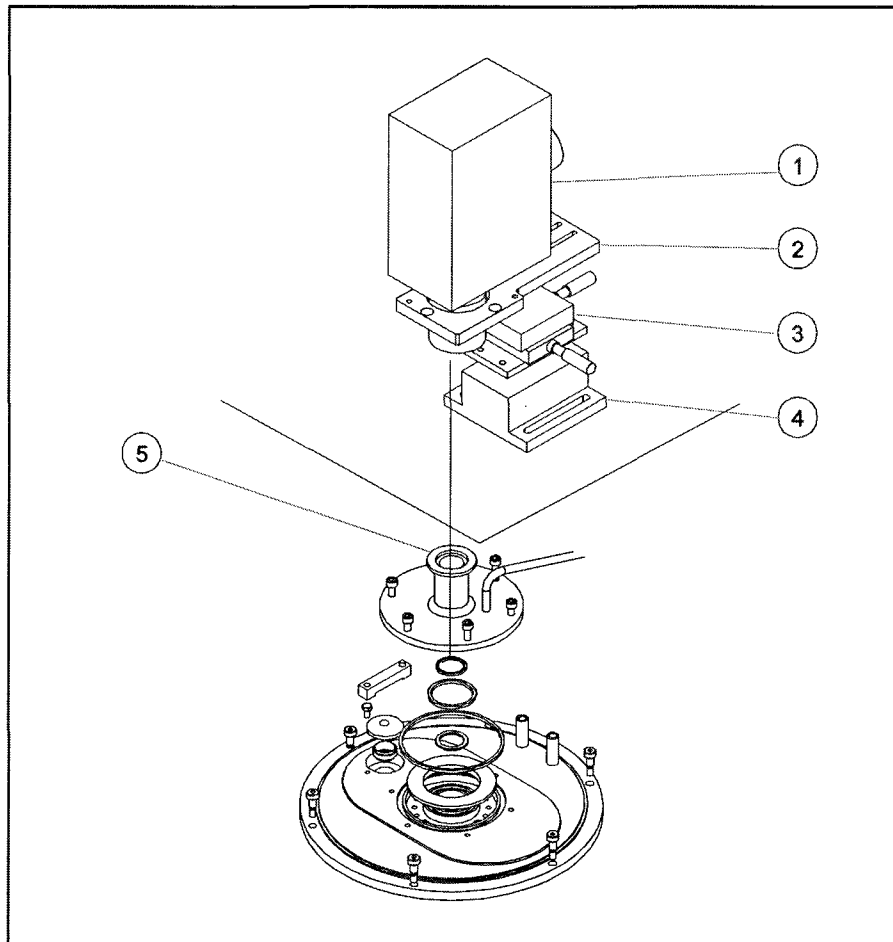

Item	Part No.	Description
1	G/SUN/END/013/4	SOFIE FL205A-1 AN. LASER REFL.
2	G/SUN/END/013/3	SLIDE/MOUNT
3	G/SUN/END/013/2	ADJUSTOR
4	G/SUN/END/013/1	BASE
5	MD81C15834	NW25KF FLANGE (INTERFEROMETRY) SEE SUB-SECTION 3.1
	G/SUN/END/013/5	CONTROL UNIT AND PANEL - LOCATED ON FRONT PANEL ABOVE RF UNIT
	EXP0801	WIN TV GO PCI CARD - LOCATED IN SYSTEM PC

12.3.4 Sofie integrated laser optional spares

OIPT Part No.	Qty	Description
MD81C15834	1	NW25KF FLANGE (INTERFEROMETRY)

NOTES:

Oxford Instruments Plasma Technology locations world-wide

UK

Oxford Instruments Plasma Technology
North End, Yatton,
Bristol, BS49 4AP
Tel: +44(0)1934 837000
Fax: +44(0)1934 837001
Email: plasma.technology@oxinst.co.uk
Web: www.oxford-instruments.com/plmchp5.htm

USA

Oxford Instruments Inc.
130A Baker Avenue Extension
Concord, MA 01742
Tel: +1 978 369 9933
Toll Free +1 800-447-4717
Fax: +1 978 369 8287
Email: info@ma.oxinst.com

Germany

Oxford Instruments GmbH
Otto-von-Guericke Ring 10,
D-65205 Wiesbaden
Tel: +49(0)6122 937161
Fax: +49(0)6122 937175
Email: plasma@oxford.de

Japan

Oxford Instruments K.K.
2-11-6 Tomioka
Koto-ku, Tokyo 135-0047
Tel: +81-3-5245-3261
Fax: +81-3-5245-4466
Email: oikcpt@oxinst.co.jp
Web: www.oxford-instruments.jp

People's Republic of China (Beijing)

Oxford Instruments China
Room 714, Office Tower 3,
Henderson Center,
No. 18 Jianguomennei Ave,
Dongcheng District,
Beijing 100005
Tel: +86 106518 8160/1/2
Fax: +86 106518 8155
Email: ptsales@oichina.cn
Web: www.oxford-instruments.com.cn

People's Republic of China (Shanghai)

Oxford Instruments China
Room 14-F, No.1 Plaza
800 Nanjing East Road
Shanghai 200001
Tel: +86 216360 8530
Fax: +86 216360 8535
Email: ptsales@oichina.cn
Web: www.oxford-instruments.com.cn

Singapore

Oxford Instruments Pte. Ltd
371 Beach Road,
#02-07 Keypoint
Singapore 199597
Tel: +65 6337 6848
Fax: +65 6337 6286
Email: oipt.sales@oxford-instruments.com.sg

Taiwan

Oxford Instruments Overseas Marketing
Ltd.
1F, No 23 Jing-Shang 19th Street,
Hsinchu, Taiwan
Tel: +65 6337 6848
Fax: +65 6337 6286
Email: oipt.sales@oxford-instruments.com.sg