



# 1100°C Box Furnace

Models: BF51800 Series

## Installation and Operation Manual



### Table of Contents

Introduction . . . . .	1
Safety Considerations . . . . .	2
Pre-Installation . . . . .	3
Installation . . . . .	3
Start Up . . . . .	6
Operation – UP150 Controller . . . . .	7
Communication Option . . . . .	9
Maintenance . . . . .	11
Troubleshooting . . . . .	15
Replacement Parts and Wiring Diagrams . . . . .	16
Warranty . . . . .	27
Material Safety Data Sheet . . . . .	29

312060H01

## Table of Contents

<b>1</b>	<b>Introduction</b> .....	<b>1</b>
1.1	Features and Benefits .....	1
1.2	Specifications .....	1
<b>2</b>	<b>Safety Considerations</b> .....	<b>2</b>
<b>3</b>	<b>Pre-Installation</b> .....	<b>3</b>
3.1	Unpacking .....	3
3.2	Operating Conditions .....	3
3.3	Atmosphere Systems .....	3
<b>4</b>	<b>Installation</b> .....	<b>3</b>
4.1	Location .....	3
4.2	Wiring .....	3
4.2.1	120 VAC Operation .....	3
4.2.2	240 VAC Operation .....	4
4.2.3	208 VAC Operation .....	4
4.2.4	120 to 208/240 VAC Conversion .....	4
4.3	Exhaust Vent .....	5
4.4	Exhaust Port Connections .....	5
4.5	Atmosphere Inlet .....	6
4.6	Atmosphere Inlet Port .....	6
<b>5</b>	<b>Start Up</b> .....	<b>7</b>
5.1	Furnace Start Up .....	7
5.2	Door Seal Check .....	7
5.3	Door Seal Adjustment (if necessary) .....	7
5.4	UP150 Controller Operation .....	7
5.5	Ramp to 200°C .....	8
5.5.1	Setting the High Temperature Alarm Setpoint .....	8
5.5.2	Setting the Local Setpoint .....	8
5.5.3	While the Furnace Is at 200°C .....	8
5.6	Ramp to 550°C .....	8
5.6.1	Resetting the High Temperature Alarm Setpoint .....	8
5.6.2	Resetting the Local Setpoint .....	9
5.6.3	While The Furnace Is at 550°C .....	9
5.7	Ramp To 1000°C and Operate for Two Hours .....	9
5.7.1	Resetting the High Temperature Alarm Setpoint .....	9
5.7.2	Resetting the Local Setpoint .....	9

<b>6</b>	<b>UP150 Controller Operation</b>	<b>10</b>
6.1	UP150 Controller Overview	10
6.2	Single Setpoint Operation	11
6.2.1	Setting High Temperature Alarm Setpoint:	11
6.2.2	Accessing Local Mode	11
6.2.3	Exiting Local Mode	11
6.3	Programming Operation: Entering a Program	11
6.3.1	Entering Programming Mode	11
6.3.2	Entering Program Parameters	12
6.3.3	Running a Program	13
6.3.4	Ending a Program	13
6.3.5	Changing a Program	13
6.4	Auto Tuning the UP150 Controller	14
6.5	Temperature Offset Procedure	14
6.6	Changing Temperature Scale Between °C and °F	15
<b>7</b>	<b>Communication Option</b>	<b>16</b>
7.1	Cable Installation	16
7.2	UP150 Communications Setup Parameters	16
7.3	Software Installation	16
7.4	Communications Test	17
7.5	Ordering SpecView	17
7.6	Troubleshooting	17
7.7	Decimal Point Adjustment	17
7.8	Addresses for Multiple Controllers	17
<b>8</b>	<b>Maintenance</b>	<b>18</b>
8.1	Door Seal Adjustment	18
8.2	Thermocouple Replacement	18
8.3	Solid-State Relay Replacement	19
8.4	Power Relay Replacement	19
8.5	Temperature Controller Replacement	20
8.6	Door Insulation Replacement	20
8.7	Heating Unit Replacement	21
<b>9</b>	<b>Troubleshooting</b>	<b>22</b>
<b>10</b>	<b>Replacement Parts and Wiring Diagrams</b>	<b>23</b>

11 **Warranty** ..... 27

    11.1 Domestic Warranty (United States and Canada) ..... 25

    11.2 International Warranty (excluding Canada)  
        12 Months Parts Warranty ..... 25

12 **Moldatherm® Insulation Material Safety Data Sheet** ..... 29

## 1 Introduction

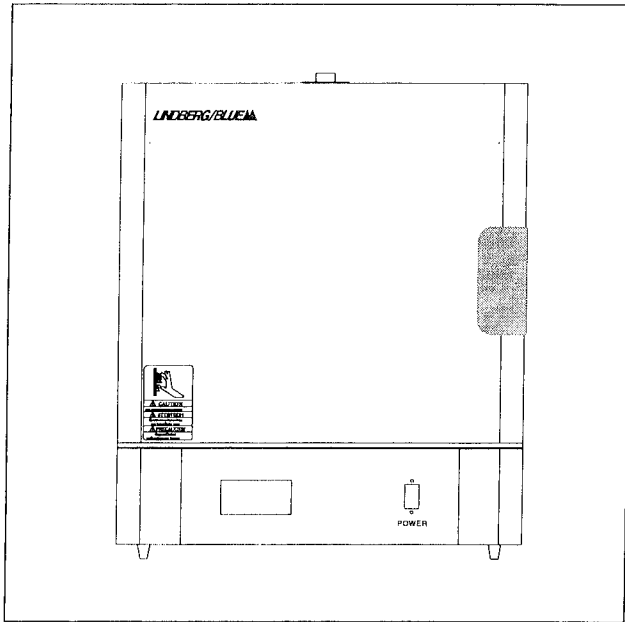

The Lindberg/Blue M BF51800 Series is a family of ultra lightweight, economical, laboratory box furnaces. The low thermal mass Moldatherm<sup>®</sup> insulation/heating element provides fast duty cycles, energy conservation, and efficient programming. Refer to Table 1 for specifications.

### 1.1 Features and Benefits

- Controlled heat-up rate eliminates thermal shock to materials.
- Quick heat-up and cool-down rates.
- Four chamber sizes.
- Energy efficient Moldatherm insulation suitable for high interior-exterior temperature differential. The unit is rated for a maximum operating temperature of 1100°C.
- Resists attack from most corrosive agents and can be used in atmospheres other than air.
- Side-hinge door for convenient operation.
- Air vent, standard.
- Atmosphere inlet port standard.
- 16 segment programmable temperature controller.
- Digital instrumentation for precise temperature setpoint and display. Microprocessor automatically optimizes control parameters during furnace operation.
- Main power ON/OFF switch on control panel.
- Safety interlock switch automatically interrupts power to heating element when door is opened. This feature protects heating element and eliminates operator's exposure to electrical shock.
- Type K thermocouple.

### 1.2 Specifications

Table 1. BF51800 Series Moldatherm Box Furnaces

Model	Dimensions W x F-B x H in. (cm)		Watts	Control Type	Voltage	Net Prod. Wt. lbs (kg)
	Chamber	Exterior				
BF51848A	4 x 8 x 4 (10.1 x 20.3 x 10.1)	15 x 20 x 17.5 (38.1 x 50.8 x 44.4)	1,800	16 Segment Programmable Controller	120/VAC 50/60 Hz	45 (20.4)
BF51848C					208/240 VAC 50/60 Hz	
BF51866A	6 x 9 x 6 (15.2 x 22.8 x 15.2)	17 x 21 x 21.5 (43.1 x 53.3 x 54.6)			120/VAC 50/60 Hz	65 (29.5)
BF51866C						
BF51894C	9 x 14 x 9 (22.8 x 35.6 x 22.8)	21 x 25.75 x 26 (53.3 x 65.4 x 66)	3,500		208/240 VAC 50/60 Hz	97 (44.0)
BF51828C	12 x 18 x 12 (30.5 x 45.7 x 30.5)	24 x 30 x 28 (60.1 x 76.2 x 71.1)	5,600			142 (64.4)

## 2 Safety Considerations



**WARNING!** Do not modify or use equipment in a manner other than expressly intended. Modification of equipment other than that for which it is explicitly designed could cause severe injury or death. Any customer after-market retrofit violates the warranty of the equipment.

Do not reconfigure the controller. Any reconfiguration of the control instrument could cause inaccurate readings, faulty instrument values, and may cause the unit to become overheated and start on fire, causing personal injury or death, product and property damage.

Do not modify or disconnect any safety features provided. Disconnection of the unit safety features could allow the unit to become overheated and start on fire, causing personal injury or death, product and property damage.

Do not use components or materials not specifically designed for this equipment. Failure to comply with this precaution could result in damage to equipment used or the furnace and may create an overheat situation. Also, do not use anything other than OEM exact replacement equipment and parts. Not using OEM replacement parts could cause faulty instrumentation readings, inoperable equipment, or temperature overshoot. Both situations may cause personal injury or death, product, and property damage.

Before using, user shall determine the suitability and integrity of the product for the intended use and that the unit has not been altered in any way. Misapplication may compromise the safety of the end user or the life of the product.



**CAUTION!** This product contains refractory ceramic fiber which can result in the following:

- May be irritating to skin, eyes, and respiratory tract.
- May be harmful if inhaled.
- May contain or form cristobalite (crystalline silica) with use at high temperature (above 871°C) which can cause severe respiratory disease.
- Possible cancer hazard based on tests with laboratory animals. Animal studies to date are inconclusive. No human exposure studies with this product have been reported.



**WARNING!** Before maintaining this equipment, read the applicable MSDS (Material Safety Data Sheets) at the back of this manual.



**WARNING!** When installing, maintaining, or removing the refractory insulation, the following precautions will minimize airborne dust and fiber:

- Keep personnel not involved in the installation out of the area.
- Use a good vacuum to clean area and equipment. Use a dust suppressant if sweeping is necessary. Do **not** use compressed air.
- Use a disposable mask suitable for nuisance dust.
- Wear long sleeve clothing, gloves, hat, and eye protection to minimize skin and eye contact. Do not wear contact lenses.
- Thoroughly wash self after work is complete.
- Launder work clothing separate from other clothes and thoroughly clean laundering equipment after use. If clothing contains a large amount of dust and/or fiber, dispose of rather than clean.
- Promptly place used ceramic fiber parts and dust in plastic bags and dispose of properly.

### 3 Pre-Installation

#### 3.1 Unpacking

Carefully unpack and inspect the unit and all accessories for damage. If you find any damage, keep the packing materials and immediately report the damage to the carrier. We will assist you with your claim, if requested. **Do not return goods to Lindberg/Blue M without written authorization.** When submitting a claim for shipping damage, request that the carrier inspect the shipping container and equipment.

#### 3.2 Operating Conditions

Sulfates, chlorides, fluorides, alkalis, and  $V_2O_5$  can have corrosive effects on the ceramic fiber. Contact Lindberg/Blue M for additional information about the effects of specific atmospheres on furnace performance.

With prolonged use, hairline cracks can develop in the insulation materials. These minor cracks will not affect the furnace's performance. We recommend turning off the furnace completely when not in use. The heating unit is not damaged by rapid heating and cooling cycles.

#### 3.3 Atmosphere Systems

The BF51800 Series furnaces are not designed for use with combustible or inert atmospheres requiring an air tight chamber. If an exhaust port is used, the furnace should not be located in an enclosed area without proper ventilation.



**WARNING!** Do not use combustible gases in this furnace.



**CAUTION!** Avoid combustible products which generate toxic or hazardous vapor or fumes. Work should only be done in a properly vented environment.

### 4 Installation

Do not exceed the electrical and temperature ratings printed on the dataplate of the furnace.



**CAUTION!** Improper operation of the furnace could result in dangerous conditions. To preclude hazard and minimize risk, follow all instructions and operate within design limits noted on the dataplate.

#### 4.1 Location

Install the furnace in a level area free from vibration. To permit proper air flow, leave at least three inches of space on all sides of the unit and 12 inches above the unit.

#### 4.2 Wiring

For detailed wiring information, refer to the wiring diagrams in Section 10 on page 23.

##### 4.2.1 120 VAC Operation

The BF51848A and BF51866A models operate on 120 VAC, 50/60 Hz, single phase. Each furnace includes a 120 VAC grounded plug and cord set. The units are completely prewired and ready for operation.

Before initial start up, inspect the furnace's wiring connections:

1. Remove the corner screws on the back panel of the furnace and detach the back panel.
2. Check that the thermocouple is securely mounted and undamaged.
3. Check the thermocouple wiring connections. Refer to Figure 1 on page 3. Red is always negative.



**CAUTION!** Failure to check thermocouple wiring connections before initial start up could result in damage to the furnace.

4. Check that all electrical connections are secure. Visually check that the door properly activates the power interrupt switch near the front of the furnace.

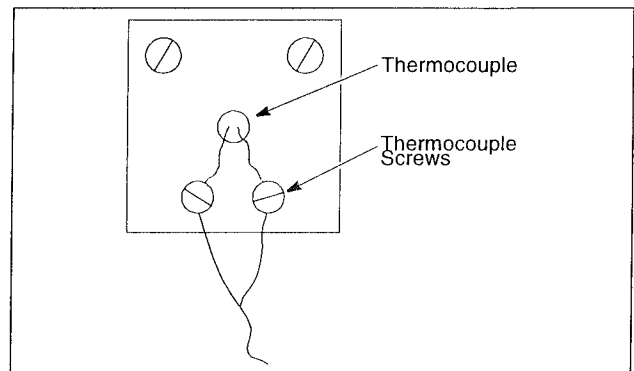

**Figure 1. Thermocouple**

5. Replace the back panel on the furnace and secure with the corner screws.
6. Plug the line cord into a 120 VAC, 20 amp, grounded line. The furnace draws approximately 15 amps (1800 W) for models BF51848 and BF51866.

### 4.2.2 240 VAC Operation

The BF51848C, BF51866C, BF51894C, BF51628C, and BF51828C models are 240 VAC furnaces.

Follow the procedure in Section 4.2.2.1 for BF51848C, BF51866C, and BF51894C models and the procedure in Section 4.2.2.2 for BF51828C models.

#### 4.2.2.1 BF51848C, BF51866C, and BF51894C Models

The BF51848C, BF51866C, and BF51894C models include a 240 VAC grounded plug and cord set. The units are completely prewired and ready for operation.

Before initial start up, inspect the furnace’s wiring connections:

1. Remove the corner screws on the back panel of the furnace and detach the back panel.
2. Check that the thermocouple is securely mounted and undamaged.
3. Check the thermocouple wiring connections. Refer to Figure 1 on page 3. Red is always negative.



**CAUTION!** Failure to check thermocouple wiring connections before initial start up could result in damage to the furnace.

4. Check that all electrical connections are secure. Visually check that the door properly activates the power interrupt switch near the front of the furnace.
5. Replace the back panel on the furnace and secure with the corner screws.
6. Plug the line cord into a 240 VAC, 20 amp, grounded line.

#### 4.2.2.2 BF51828C Models

The BF51828C 240 VAC furnaces do not include a 240 VAC grounded plug and cord set.

Furnace installation requires two power wires and one ground wire (not provided). The required power wire size is 10 GA, 23.3 amps @ 240V.

To connect the furnace to the power source, complete the following steps:

1. Determine the length of wire needed to connect the furnace to the power source.
2. Label the power wires *Line 1* and *Line 2* and label the ground wire *Ground*.
3. Remove the two cover screws and the cover.
4. Make a 7/8 inch knockout in the cover.
5. Thread the Line 1, Line 2, and Ground wires through the 7/8 inch hole. Use appropriate conduit and clamps for the service wire. Use wire nuts to connect the wires to the appropriate lead wires:

Wire	Label
Line 1	L1
Line 2	L2
Ground	GND

6. Check that the thermocouple is securely mounted and undamaged. Check the thermocouple wiring connections. Refer to Figure 1. Red is always negative.



**CAUTION!** Failure to check thermocouple wiring connections before initial start up could result in damage to the furnace.

7. Check that all electrical connections are secure. Visually check that the door properly activates the power interrupt switch near the front of the furnace.
8. Place the back panel on the furnace and secure with the corner screws.

### 4.2.3 208 VAC Operation

Lindberg/Blue M Moldatherm box furnace heating elements are specifically designed for operation on 120, 208, or 240 VAC. A furnace wired for 240 VAC operation can also operate on 208 VAC. However, heatup and recovery times will be longer.

#### 4.2.4 120 to 208/240 VAC Conversion

Although the BF51848A and BF51866A models are factory wired to operate on 120 VAC, they can be converted to 208/240 VAC operation.

The conversion procedure requires replacing the power relay and changing the jumper configuration of the elements. If you plan to convert from 120 VAC to 208/240 VAC operation, please contact the service department.



**4.3 Exhaust Vent**

Flow from the exhaust vent on the top of the unit can be adjusted by inserting or removing the plug provided.

For most applications, the exhaust vent should be fully plugged during operation of the furnace; a closed vent results in more efficient operation and greater temperature stability. However, there are some applications which benefit from a partially or fully open exhaust vent.

The exhaust vent should be partially or fully open for the following applications:

- To provide slow cool down of work load. Some work loads may be damaged by heat shock when the furnace door is opened. The vent can be opened to allow work load to cool gradually.
- To remove unwanted vapors and gases from the furnace chamber. If you need to ventilate vapors and gases outside of the room, be sure to read Section 4.4.

Figure 2 shows how you can use the plug to adjust flow from the exhaust vent.

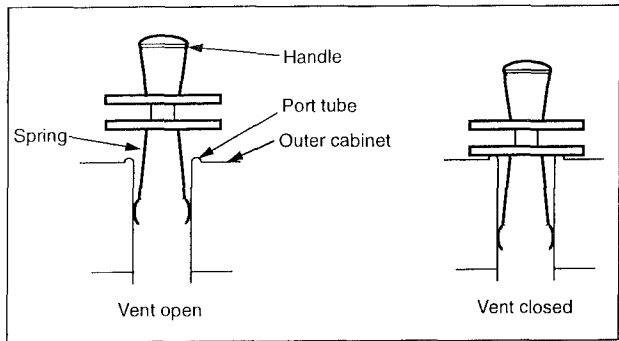

**Figure 2. Exhaust Vents**

**4.4 Exhaust Port Connections**

The one inch diameter exhaust port through the top wall of the furnace allows for the removal of unwanted vapors and gases produced during high-temperature operation.

When you need to ventilate vapors and gases outside of the room, be sure to make a proper connection to the exhaust port that allows some room air to flow into the exhaust. This is necessary to prevent “chimney effect” which sucks heat out of the chamber and results in slow run-up time or poor temperature uniformity.

Two methods of making the exhaust port connection are shown in Figure 3 below. With a hood suspended above the furnace, be sure that there is at least three inches between the hood and the exhaust port. If you use a metal tube or pipe leave at least one inch clearance.

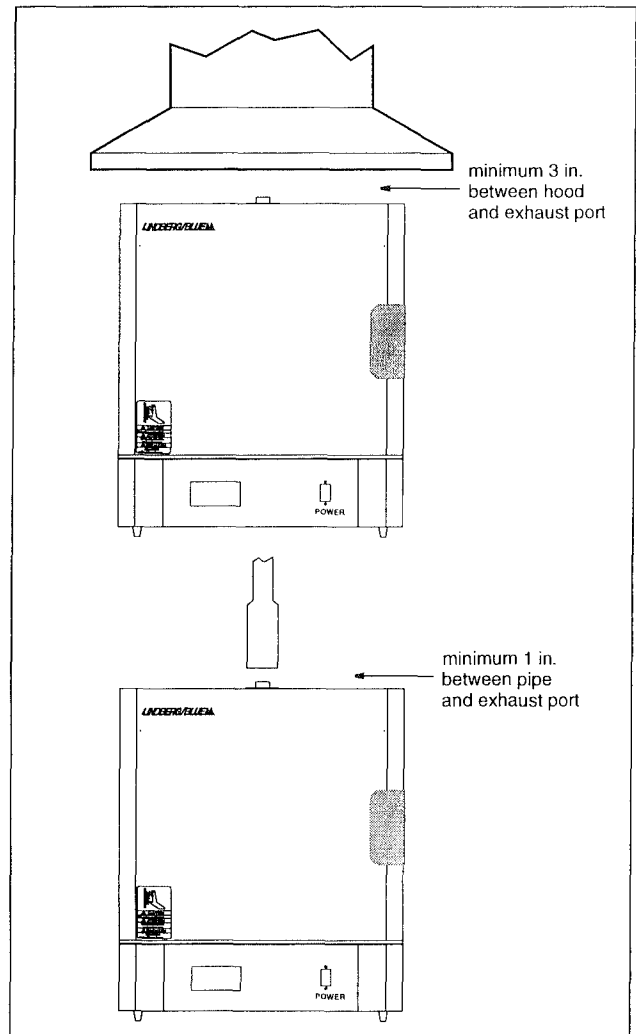

**Figure 3. Preventing Chimney Effect**

#### 4.5 Atmosphere inlet

BF51800 series furnaces have a factory-installed air/atmosphere inlet.

Most inert atmospheres (nitrogen, argon, and helium, for example) can be safely run in this box furnace. However, maximum temperatures may be derated depending on atmosphere. An initial burn-in period in air is recommended.

Please contact Lindberg/Blue M prior to using the furnace with an inert atmosphere.

The furnace should be run for 7-10 hours at 1100°C before using an inert atmosphere and after every 60 hours of use with an inert atmosphere. This burn in process will help remove contaminants and provides a protective oxide layer on the heating elements.

***This furnace is not designed to be a gas-tight atmosphere furnace.*** Other furnace models with atmosphere-tight retorts are available from Lindberg/Blue M when an atmosphere-tight chamber is required. Please consult Lindberg/Blue M for more information on gas-tight retorts and furnaces.

#### 4.6 Atmosphere Inlet Port

The atmosphere inlet tube assembly has been packaged separately to avoid breakage during shipping and handling.

***Even if you do not intend to use the gas inlet, you must install the assembly before operating the furnace.*** The only tool you need is a Phillips head screwdriver.

To install the gas inlet assembly:

1. Carefully remove the assembly from the package and inspect for any damage.
2. Remove the two mounting screws from the rear housing panel of the furnace.
3. Insert the ceramic tube end through the access hole in the rear of the furnace and guide the tube into the back of the chamber.
4. Align the mounting holes in the rear housing panel with the holes in the gas inlet tube assembly and secure the assembly with the mounting screws.

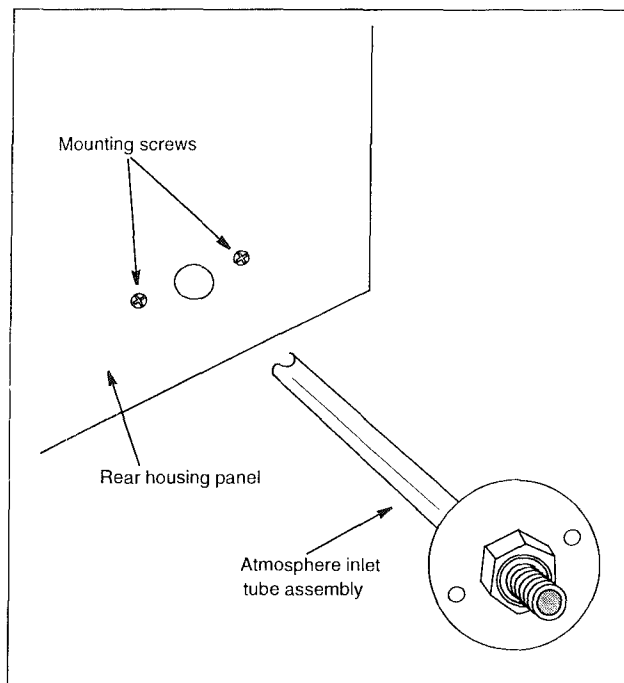

Figure 4. Gas Inlet Tube Assembly

## 5 Start Up



**CAUTION!** Observe the following precautions when operating the furnace:

- Never stand in front of an open furnace.
- Wear protective eyewear.
- Wear protective gloves.
- Use tongs to insert and remove furnace load.
- Do not allow the load to touch the furnace walls.
- Always use a hearth plate on the furnace bottom.



**WARNING!** Before operating this equipment, read the applicable MSDS (Material Safety Data Sheets) at the back of this manual.



**WARNING!** When installing, maintaining, or removing the refractory insulation, the following precautions will minimize airborne dust and ceramic fiber:

- Keep personnel not involved in the installation out of the area.
- Use a good vacuum to clean area and equipment. Do **not** use compressed air.
- Use NIOSH high efficiency respirator (3M #8710 or equivalent).
- Wear long sleeve clothing, gloves, hat, and eye protection to minimize skin and eye contact. Do not wear contact lenses.
- Thoroughly wash self after work is complete.
- Launder work clothing separate from other clothes and thoroughly clean laundering equipment after use. If clothing contains a large amount of dust and/or ceramic fiber, dispose of rather than clean.
- Promptly place used ceramic fiber parts and dust in plastic bags and dispose of properly.

### 5.1 Furnace Start Up

The furnace has a power interrupt switch. Opening the furnace door shuts off power to the heating unit. The door must be completely closed before the furnace will operate.

To start up the furnace and prepare it for normal operation, complete the following steps:

1. Check the door seal (refer to Section 5.2).
2. Turn furnace ON.
3. Using the program described in Section 5.5, run the furnace for two hours at 200°C.
4. Check for heat loss through the door. In the event of heat loss, recheck the door seal (refer to Section 5.2 and Section 5.3).
5. Adjust the setpoint to 550°C as directed in Section 5.6.
6. Run the furnace for two hours at 550°C.
7. Check for heat loss through the door. In the event of heat loss, recheck the door seal (refer to Section 5.6.3).
8. Run the furnace for two hours at 1,000°C as directed in Section 5.7.
9. Let the furnace cool to room temperature.

### 5.2 Door Seal Check

*It is very important to check the door seal before using this furnace. Door seal integrity is essential to maintain temperature uniformity and prevent fumes being released into the area surrounding the furnace.*

To check the door seal:

1. With the furnace power off and the chamber cold, open the door.
2. Insert a strip of paper (a couple of inches wide) between the door insulation and the chamber opening. Do not position the paper in the corner of the chamber. Close the door.
3. Slowly pull the paper strip from the outside. You should feel some resistance. If the paper does not pull out, this area of the door seal may be too tight, causing a gap in another area of the door seal.
4. Repeat this test at 2-inch intervals around the door. If the door does not seal properly, a door adjustment must be done (see Section 5.3, below).

### 5.3 Door Seal Adjustment (if necessary)

To adjust the door seal:

1. Door assemblies have hex nuts attaching the insulation frame to the outer door frame. Loosen the appropriate nuts and move the door insulation frame to improve the door seal.
2. Recheck the door seal, following the instructions above.
3. If a gap is detected only in the center top edge of the door seal, then the top corners of the sealing surface of the door may be sanded to lessen the center gap.
4. After each adjustment recheck the door seal.

The door seal has been adjusted properly if there is no heat loss when operating the furnace up to 500°C.

### 5.4 UP150 Controller Operation

The furnaces described in this manual all use the UP150 programmable controller, Version 54. The programmer/controller will not operate the heaters (to change or maintain a temperature above ambient) unless a local setpoint has been selected or a specified program is running.

If at any time the controller buttons have not been pushed for 2 minutes, the controller will return to the regular display of process temperature and operating setpoint.

The following sections explain how to enter and run the programs recommended to prepare the furnace for normal operation. For more detailed configuration information, refer to Section 6 on page 10.

### 5.5 Ramp to 200°C

The simple start-up program described below is designed to direct the controller to operate through a simple ramp-to-higher-temperature, stabilize, and hold indefinitely. This will give the

operator the necessary time to check the door seal and allow the furnace insulation to normalize.

### 5.5.1 Setting the High Temperature Alarm Setpoint

The first step is to set the high temperature alarm to 210°C:

1. Press and HOLD for three seconds the 'SET/ENT' button to display "modE rES".
2. Press and release the 'SET/ENT' button to display "PrG 0".
3. Press the 'UP/RESET' Button to show the lower display value of "1".
4. Press and release the 'SET/ENT' button to select this new value and advance to the "SSP 25" display.
5. Press and release the 'SET/ENT' button until the High Temperature Alarm Setpoint value is displayed as "A1".
6. Select an alarm setpoint 10°C above the target setpoint to be selected. In this instance select "210".
7. Press and release the 'SET/ENT' button to place this new value in the controller memory.
8. Press and HOLD for three seconds the 'SET/ENT' button to exit this menu.

### 5.5.2 Setting the Local Setpoint

Next, set the local setpoint to 200°C:

1. Make sure the indicators beside "RUN" and "L" on the controller face are off. If either indicator is on, press and hold the 'SET/ENT' button until the display shows 'modE'. Select 'rES' in the lower display with the 'arrow' buttons. Press and release the 'SET/ENT' button once.
2. Press and release 'SET/ENT' until "LoC" is displayed. Make sure the value below "LoC" is "0" (zero). If it is *not* "0" use the 'down arrow' to make "0" and press and release "SET/ENT" button to register the change to "0".
3. Press and release the 'SET/ENT' button until "modE" is displayed.
4. At "modE" display, press the 'UP' arrow button to make the lower value "LCL". Press and release the 'SET/ENT' button once to enter the local mode.
5. Use the 'UP' and 'DOWN' buttons to select the operating temperature setpoint of "200".
6. Press and release the 'SET/ENT' button once to select this setpoint value. This will show the display with the measured temperature in the upper display, the lower display showing the present temperature setpoint.

This display and the buttons will remain active as long as power is being supplied to the control module.

In this display mode, the arrow buttons can be used to adjust local setpoint, shown in the lower display. *After adjusting a value, always remember to press 'SET/ENT' to register the change.*

### 5.5.3 While the Furnace Is at 200°C

After the furnace operates at 200°C for 2 hours, check for heat loss in the area above the door and cabinet meet together.

If no heat loss is detected, then proceed to the next temperature level.

If heat loss is detected, stop the controller operations, cool the furnace to room temperature and recheck the door seal.

In case you need to stop and check the door seal, exit the Single Setpoint or Local Mode and turn off the energy to the heaters.

**Note:** *Follow these steps only if heat loss has been detected and you need to shut off the heaters to recheck the door seal.*

To exit single setpoint mode:

1. Press and hold for three seconds the 'SET/ENT' button to display "modE LCL".
2. Press and release the 'DOWN' button twice to select the display "modE rES".
3. Press and release the 'SET/ENT' button once to select the Reset Mode. At this point, the red indicator light should go off beside the display label "L" (Local Mode).

This will change the display showing the measured temperature in the upper display, with the lower display showing the Start Set Point (SSP) temperature setpoint of the program.

## 5.6 Ramp to 550°C

The next step in the startup procedure is to ramp to 550°C and hold.

### 5.6.1 Resetting the High Temperature Alarm Setpoint

1. Press and HOLD for three seconds the 'SET/ENT' button to display "modE rES".
2. Press and release the 'SET/ENT' button to display "PrG 0".
3. Press the 'UP/RESET' Button to show the lower display value of "1".
4. Press and release the 'SET/ENT' button to select this new value and advance to the "SSP 25" display.
5. Press and release the 'SET/ENT' button until the High Temperature Alarm Setpoint value is displayed as "A1".
6. Select an alarm setpoint 10°C above the target setpoint to be selected. In this instance select "560".
7. Press and release the 'SET/ENT' button to place this new value in the controller memory.
8. Press and HOLD for three seconds the 'SET/ENT' button to exit this menu.

### 5.6.2 Resetting the Local Setpoint

Next, set the local setpoint to 550°C:

1. Make sure the indicators beside “RUN” and “L” on the controller face are off. If either indicator is on, press and hold the ‘SET/ENT’ button until the display shows ‘modE’. Select ‘rES’ in the lower display with the ‘arrow’ buttons. Press and release the ‘SET/ENT’ button once.
2. Press and release ‘SET/ENT’ until “LoC” is displayed. Make sure the value below “LoC” is “0” (zero). If it is *not* “0” use the ‘down arrow’ to make “0” and press and release “SET/ENT” button to register the change to “0”.
3. Press and release the ‘SET/ENT’ button until “mode” is displayed.
4. At “mode” display, press the ‘UP’ arrow button to make the lower value “LCL”. Press and release the ‘SET/ENT’ button once to enter the local mode.
5. Use the ‘UP’ and ‘DOWN’ buttons to select the operating temperature setpoint of “550”.
6. Press and release the ‘SET/ENT’ button once to select this setpoint value. This will show the display with the measured temperature in the upper display, the lower display showing the present temperature setpoint.

### 5.6.3 While The Furnace Is at 550°C

After the furnace operates at 550°C for 2 hours, check for heat loss in the area above the door and cabinet meet together.

If *no significant* heat loss is detected, then proceed to the next temperature in this start-up procedure.

If *substantial* heat loss is detected (compared to the rest of the cabinet top), stop the controller program (as described in Section 5.5.3 on page 8), cool the furnace to room temperature and recheck the door seal.

## 5.7 Ramp To 1000°C and Operate for Two Hours

If the highest planned temperature setpoint is less than 1000°C, this alternate temperature may be used for this step.

### 5.7.1 Resetting the High Temperature Alarm Setpoint

1. Press and HOLD for three seconds the ‘SET/ENT’ button to display “modE rES”.
2. Press and release the ‘SET/ENT’ button to display “PrG 0”.
3. Press the ‘UP/RESET’ Button to show the lower display value of “1”.
4. Press and release the ‘SET/ENT’ button to select this new value and advance to the “SSP 25” display.
5. Press and release the ‘SET/ENT’ button until the High Temperature Alarm Setpoint value is displayed as “A1”.
6. Select an alarm setpoint 10°C above the target setpoint to be selected. In this instance select “1010”.
7. Press and release the ‘SET/ENT’ button to place this new value in the controller memory.
8. Press and HOLD for three seconds the ‘SET/ENT’ button to exit this menu.

### 5.7.2 Resetting the Local Setpoint

Next, set the local setpoint to 1000°C:

1. Make sure the indicators beside “RUN” and “L” on the controller face are off. If either indicator is on, press and hold the ‘SET/ENT’ button until the display shows ‘modE’. Select ‘rES’ in the lower display with the ‘arrow’ buttons. Press and release the ‘SET/ENT’ button once.
2. Press and release ‘SET/ENT’ until “LoC” is displayed. Make sure the value below “LoC” is “0” (zero). If it is *not* “0” use the ‘down arrow’ to make “0” and press and release “SET/ENT” button to register the change to “0”.
3. Press and release the ‘SET/ENT’ button until “mode” is displayed.
4. At “mode” display, press the ‘UP’ arrow button to make the lower value “LCL”. Press and release the ‘SET/ENT’ button once to enter the local mode.
5. Use the ‘UP’ and ‘DOWN’ buttons to select the operating temperature setpoint of “1000”.
6. Press and release the ‘SET/ENT’ button once to select this setpoint value. This will show the display with the measured temperature in the upper display, the lower display showing the present temperature setpoint.
7. Let the furnace run for two hours after achieving the 1000°C setpoint.

This ends the third and final step in the furnace start-up procedure. Turn off the power to this furnace and let it cool to room temperature. Keep the door closed until the furnace is cool.

## 6 UP150 Controller Operation

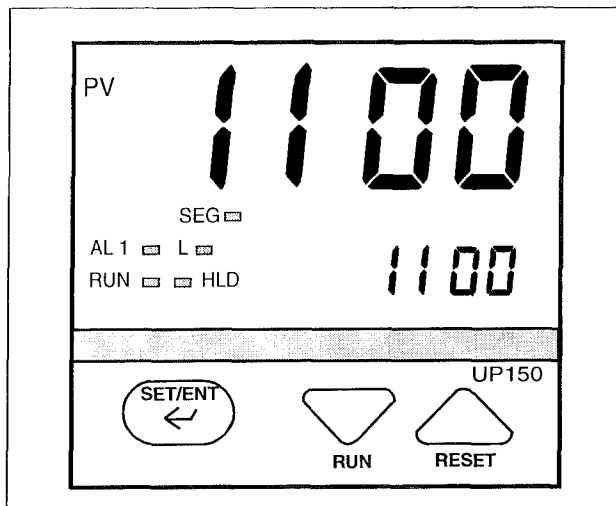

Figure 5. UP150 Control Panel

The furnace temperature controller is configured and tuned at the factory to function well for most applications. Occasionally, it may be advisable to configure the temperature controller differently to suit a particular working environment or process.



**CAUTION!** Before reconfiguring the controller, read this chapter carefully. Reconfiguring the controller can change the unit characteristics and design parameters, which can hamper performance and make the equipment dangerous to use.

### 6.1 UP150 Controller Overview

This version (V 54) of the UP150 controller features the dual operation modes of Single Setpoint and Programming. Each mode has distinct operations and uses.

Single Setpoint Mode allows the user to select a single target temperature setpoint in the controller. The controller will then operate the heating equipment until this setpoint value is achieved.

Programming Mode allows the user to enter a series of setpoint and time values. The controller will follow these sequences of instructions to energize the heating equipment until the entire sequence is complete.

The Temperature Controller senses the chamber air temperature of the furnace (the PV, or process value) and supplies the heat necessary to achieve the desired setpoint. The controller includes an LED display and a pushbutton keypad. Refer to Table 2 and Table 3 for lists of displayed parameters and keypad functions.

Table 2. UP150 Parameter Functions

Parameter Code	Factory Set Value	Description
<i>Operating parameters (access by holding the SET/ENT key)</i>		
MODE	RST	Model Selection
HoLd	OFF	Program Hold (RUN mode)
AdV	OFF	Segment Advance (RUN mode)
CtL	Pid	Control mode
At	oFF	Auto tuning (RUN mode)
P	20	Proportional band (°C; °F=38)
I	120	Integral time
d	30	Derivative time
Ct	1	Heat cycle time
FL	OFF	Sensor filter
bS	0.0	PV bias (offset)
LoC	1	Key lock
<i>Setup parameters (access by setting LoC=-1)</i>		
In	1	Input type (J thermocouple)
SPH	1100	High Setpoint Limit (°C; °F=2012)
SPL	0	Low Setpoint Limit (°C; °F=32)
tmU	0	Program Time Limit (h.m)
SC	ON	Super function
dr	0	Direct/Reverse Action

Table 3. Pushbutton Keypad

Button	Function
	Pressing and holding the SET/ENT for three seconds advances the display to the Operation Parameters Menu. While in the Operation Parameters Menu, use SET/ENT to move from one parameter to the next, and to register changes you have made in setpoint and parameter values. Holding SET/ENT for three seconds exits either the Operation or Setup Parameters menu.
	Use the Up Arrow button to increase the temperature setpoint display and to change parameter values in the Operation and Setup Parameter menus. Whenever you change the value of a setpoint or parameter, the decimal point flashes to remind you to register the changed value with SET/ENT. While in operating mode, pressing this button stops (resets) program operation.
	Use the Down Arrow button to decrease the temperature setpoint display and to change parameter values in the Operation and Setup Parameter menus. Whenever you change the value of a setpoint or parameter, the decimal point flashes to remind you to register the changed value with SET/ENT. While in operating mode, pressing this button starts (runs) a program

## 6.2 Single Setpoint Operation

The following sections describe how to operate the controller in single setpoint (local) mode. Use this mode when you only need to run the furnace with a specific setpoint and do not require a programmed sequence of steps.

### 6.2.1 Setting High Temperature Alarm Setpoint:

1. Press and HOLD for three seconds the 'SET/ENT' button to display "modE rES".
2. Press and release the 'SET/ENT' button to display "PrG 0".
3. Press the 'UP/RESET' Button to show the lower display value of "1".
4. Press and release the 'SET/ENT' button to select this new value and advance to the "SSP 25" display.
5. Press and release the 'SET/ENT' button until the High Temperature Alarm Setpoint value is displayed as "A1".
6. Select an alarm setpoint 10°C above the target setpoint to be selected.
7. Press and release the 'SET/ENT' button to place this new value in the controller memory.
8. Press and HOLD for three seconds the 'SET/ENT' button to exit this menu.

### 6.2.2 Accessing Local Mode

1. Press and hold for three seconds the 'SET/ENT' button to display "modE rES".
2. Press and release the 'UP' button twice to select the display "modE LCL".
3. Press and release the 'SET/ENT' button once to select Local Mode. This selection causes the red indicator to illuminate beside "L" on the control panel (refer to Figure 5).
4. Use the 'UP' and 'DOWN' buttons to select the desired operating temperature setpoint.
5. Press and release the 'SET/ENT' button once to register the setpoint value.
6. The display will then show measured temperature in the upper display, the present temperature setpoint in the lower display.
7. This display and the buttons will remain active as long power continues to the control module. Power interruptions will cause the controller to enter reset or standby mode in which no actions are made to operate the heating equipment.

You may use the arrow buttons to adjust the setpoint (lower) value to be adjusted in this display mode. The 'SET/ENT' button will register setpoint value changes, until these values are changed again.

### 6.2.3 Exiting Local Mode

To exit Single Setpoint or Local Mode and turn off the energy to the heaters:

1. Press and hold for three seconds the 'SET/ENT' button to display "modE LCL".
2. Press and release the 'DOWN' button twice to select the display "modE rES".
3. Press and release the 'SET/ENT' button once to select the Reset Mode.  
This selection causes the red indicator to extinguish beside the display label "L" that had indicated the Local Mode.
4. This will change the display showing the measured temperature in the upper display, with the lower display showing the Start Set Point (SSP) temperature setpoint of the program.

## 6.3 Programming Operation: Entering a Program

This section describes how to enter a simple program that is designed to:

- direct the controller to ramp to a higher temperature;
- stabilize;
- ramp to a lower-temperature;
- end with an indefinite dwell.

If you intend to use the program features of the controller, it is advisable to go through all the steps in this sample program to familiarize yourself with the elements of programming mode.

**Note:** *If the controller buttons are NOT pushed for 2 minutes, the controller will return to the regular operator mode/menu.*

### 6.3.1 Entering Programming Mode

To access the programming menu:

1. Make sure the indicators beside "RUN" and "L" on the controller face are off. If either indicator is on, press and hold the 'SET/ENT' button until the display shows 'modE'. Select 'rES' in the lower display with the 'arrow' buttons. Press and release the 'SET/ENT' button once.
2. Press the 'SET/ENT' button for 3 seconds to display "modE" in the upper display and "rES" (Reset) in the lower display.
3. Press and release 'SET/ENT' until "LoC" is displayed. Make sure the display below "LoC" is "0" (zero). If it is not "0", use 'DOWN ARROW' to select "0" and press and release "SET/ENT" button to register the change to "0".
4. Press and release the "SET/ENT" button until "PrG" is displayed.
5. At "PrG" display, press the 'UP ARROW' to make the lower display "1".
6. Press and release the 'SET/ENT' button once to enter the programming menu.

### 6.3.2 Entering Program Parameters

The first display is the Start Set Point parameter, shown as “SSP” in the upper display. The value assigned to SSP is usually the current room temperature, 25°C.

On the next page is an illustration of the program profile and a table of the parameters entered.

#### Basic Ramp and Dwell Parameters:

1. Use the arrow buttons to select “25” in the lower display, then press and release the ‘SET/ENT’ button twice to enter this new value and to advance to the “StC” display. If the value for “SSP” is correct and does not need to be changed, press and release the ‘SET/ENT’ button once to advance to the “StC” display.
2. Next is the Start Code parameter, shown as “StC” in the upper display. The value assigned to StC is usually “0”. This will instruct the program to follow the Start Set Point. Press the SET/ENT button to advance to the next display.
3. The next parameter, “SP1”, is the first setpoint value that is desired in the chamber and is normally a ramp segment. Select this target temperature setpoint value with the arrow buttons then press and release the ‘SET/ENT’ button twice to enter this value and to advance to the “tM1” display. If the value for “SP1” is correct and will not be changed, press and release the ‘SET/ENT’ button once to advance to the “tM1” display.
4. The next parameter, “tM1”, represents the first time period for the unit to reach the target temperature setpoint selected in “SP1”. This selection can be a value ranging from 0.00 to 99.59, which represents hours and minutes. Select this time value with the arrow buttons and enter it by pressing and releasing the ‘SET/ENT’ button twice.
5. Press and release the ‘SET/ENT’ button to advance to the next display of “SP2”, this is normally the dwell segment. Select the same target setpoint temperature value as “SP1” with the arrow buttons. Press and release the ‘SET/ENT’ button twice to enter this value and to advance to the next display.
6. The next parameter, “tM2”, represents the second time period used to maintain or dwell at the target setpoint selected in “SP2”. This selection can be a value ranging from 0.00 to 99.59, which represents hours and minutes. Select this time value with the arrow buttons and enter it by pressing and releasing the ‘SET/ENT’ button twice.
7. Next, “SP3” is the third setpoint value desired in the chamber. Select this target temperature setpoint with the arrow buttons and press and release the ‘SET/ENT’ button twice to enter this value and to advance to the “tM3” display. If this value is correct and not changed, press and release the ‘SET/ENT’ button once to advance to the “tM3” display.
8. “tM3” represents the third time period for the unit to reach the target setpoint selected in “SP3”. This selection can be a value ranging from 0.00 to 99.59, which represents hours and minutes. Select this value with the arrow buttons and enter it by pressing and releasing the ‘SET/ENT’ button.
9. The next parameter, “SP4” is normally the dwell segment. Select the same target temperature as “SP3” with the arrow buttons, then press and release the ‘SET/ENT’ button twice to enter this new value and to advance to the next display.

#### Additional Program Parameters”

10. The next parameter displayed is “tM4”. Select a lower display value of “oFF” with the ‘arrow’ buttons, then press and release the ‘SET/ENT’ button twice to enter this value change and advance to the next display.
11. The next display shows “EV1” in the upper display. The lower value should always be “0” (zero). Press and release the ‘SET/ENT’ button once to go to the next display.
12. “AL1” should always have a lower value of “9”. Press and release the ‘SET/ENT’ button once to advance to the next display.
13. The next parameter, “A1”, is used to select the high temperature alarm trip setpoint. Use the ‘arrow’ buttons to select a value 10°C (or 20°F) HIGHER than the **highest** target setpoint to be used. Select the High Temperature Alarm value with the arrow buttons then press and release the ‘SET/ENT’ button twice to enter this new value and to advance to the “HY1” display. If the value for “A1” is correct and not changed, press and release the ‘SET/ENT’ button once to advance to the “HY1” display.
14. “HY1” is used to select the amount of temperature change below the high temperature alarm setpoint where the alarm relay will reset. This value is usually “1”. Select “1” with the arrow buttons and press the ‘SET/ENT’ button six times to enter the correct value and advance to the “JC” display. Or if the value is correct, press the ‘SET/ENT’ button five times to advance to the “JC” display.
15. For the parameter displayed as “JC”, select “1” with the arrow buttons, then press and release the ‘SET/ENT’ button twice to display “WTZ”. Selecting the value of “1” will cause the program to hold the setpoint at this last segment. A value of “0” would cause the program to reset and stop running the program and stop the power to the heaters. A value of “2” will cause the program to repeat ‘continuously’.
16. When the display shows “WTZ”, select a lower display value of “oFF” with the ‘arrow’ buttons. Press and HOLD the ‘SET/ENT’ button for 3 seconds to return to the Reset or standby display.

This concludes the steps required to enter a typical ramp-and dwell program. On the next page is an illustration of the program profile and a table of the parameters entered.



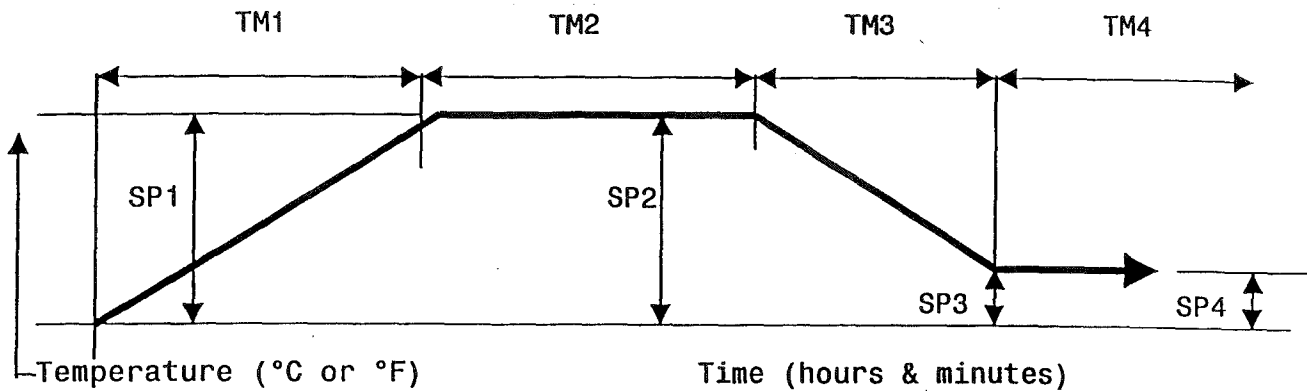

In the table below, '\*' denotes values typically set by the user according to the needs of a program.

Parameter	Value	Meaning	Parameter	Value	Meaning
PrG	0	Enters program menu	SP4	*	Segment 4 Setpoint
SSP	25	Start Setpoint	tm3	oFF	Time length for Segment 4
StC	0	Start Code	EV1	0	Event 1
SP1	*	Segment 1 Setpoint	AL1	9	Alarm 1
tm1	*	Time length for Segment 1	HY1	1	Hysteresis for alarm 1
SP2	*	Segment 2 Setpoint	EV2	0	Event 2
tm2	*	Time length for Segment 2	AL2	oFF	Alarm 2
SP3	*	Segment 3 Setpoint	JC	1	Junction code (1=dwell; 0=stop; 2=repeat)
tm3	*	Time length for Segment 3	wtz	oFF	Wait Zone

Figure 6. Typical Program Profile and Table of Parameters

### 6.3.3 Running a Program

To run a program such as the one outlined above, press and hold the 'DOWN/RUN' button making the 'RUN' indicator illuminate. At the end of this program the 'HLD' (hold) indicator is illuminated to indicate this program is in the indefinite dwell at the last target temperature. This hold indicator is caused by the "JC" selection of "1", while the "JC" selections of "0" or "2" will not illuminate the 'HLD' (hold) indicator.

### 6.3.4 Ending a Program

To end a program while in the 'RUN' or 'HLD' (hold) mode, press and hold the 'UP/RESET' button to turn off the current program and extinguish the 'RUN' or 'HLD' indicator.

Turning off the unit's power will also stop the program. When power is restored, the controller is in the Reset or standby mode with no power to the heaters.

**Note:** *The programmer/controller will not operate the unit's heaters (to change or maintain a temperature) unless there is a program running or a single setpoint value is selected in the Local Mode.*

### 6.3.5 Changing a Program

To make changes ONLY to the target temperature and segment length times for simple program operation, follow these steps:

1. Make sure the indicators beside "RUN" and "L" on the controller face are off. If either indicator is on, press and hold the 'SET/ENT' button until the display shows 'mode'. Select 'rES' in the lower display with the 'arrow' buttons. Press and release the 'SET/ENT' button once.
2. Press the 'SET/ENT' button for 3 seconds to display "mode" in the upper display and "rES" in the lower display. Press and release 'SET/ENT' repeatedly to display "LoC". Make sure the value below "LoC" is "0" (zero). If it is not "0", use 'DOWN' arrow to select "0" and press and release "SET/ENT" button to register the change to "0".
3. Press and release the 'SET/ENT' button once to show "PrG" on the upper display.
4. Press the 'UP' arrow to make the lower value "1".
5. Press and release 'SET/ENT' button twice to display "SP1". Using the arrow buttons to revise the target setpoint.
6. Press and release 'SET/ENT' button twice to display "tm1". Using the arrow buttons to revise the segment time length needed to get to the target setpoint 'SP1'.
7. Press and release 'SET/ENT' button to display other setpoints and segment time lengths. Use the arrow buttons to change the temperature setpoints and time lengths. Press and release the 'SET/ENT' button to register any new values.

8. Press and HOLD the 'SET/ENT' button for 3 seconds to exit the program menu and return to the reset or standby display.

#### 6.4 Auto Tuning the UP150 Controller

Auto tuning maximizes the performance of the chamber at a selected temperature with the product load's characteristics, by operating with the quickest response and minimal temperature overshoot.

Factory settings are for general purposes, but your process can be enhanced through the auto tune feature. To obtain this maximum performance, follow these steps to auto tune the controller.

1. Load the chamber with materials that have the same mass and thermal characteristics as an actual product load.
2. Operate the chamber to the process temperature.
3. Start the Auto Tune: Press and hold the 'SET/ENT' button for three seconds to display the "modE" parameter of the Operating Parameter menu.
4. Press and release the 'SET/ENT' button five times to advance to the "At" parameter.
5. Press and release the 'UP' arrow button to show "on" in the lower display.
6. Press the 'SET/ENT' button once to enter the auto tune mode and exit the Operating Parameters menu.
7. The controller will cycle three times through a heating and cooling pattern, measuring the characteristics of the load and chamber temperature controls. During the auto tuning, 'At' will alternately flash with the measured temperature (PV) display to indicate that the auto tuning is in progress. The length of time for the auto tune varies with the load, chamber size and temperature selected.
8. The auto tune is completed when the regular display of the measured temperature is shown without the "At" value flashing. The chamber should now operate to the process temperature with the given product load, with the quickest response and minimal temperature overshoot.
9. If the process temperature or load changes significantly, another auto tune session may be necessary to optimize the chamber performance.

To interrupt the auto tune before it is completed, simply turn off the power to the controller and unit. When the power is restored the auto tune will not be operating.

#### 6.5 Temperature Offset Procedure

The purpose of this procedure is to create an offset in the displayed temperature measurement for the Yokogawa model UP150 temperature controller.

1. Operate the oven or furnace chamber to your normal stable temperature setpoint, with an independent temperature measurement device located in the center of the chamber. The controller will be 'running' the program or operating in the local mode to maintain the temperature.
2. Note any difference in the controller's measured temperature (upper value) and the independent measurement. If a difference of greater than 1°C is noted proceed with the following steps.
3. Press and hold the "SET/ENT" button for 3 seconds to display "modE".
4. Verify the button lockout parameter will give access to make this display offset. Press and release the "SET/ENT" button twelve times to display "LoC". The value 0 (zero) displayed will give full access and is necessary to make the display offset changes desired. If the value displayed is 1 or 2, use the "down arrow" button to make 0 (zero) and press and release the "SET/ENT" button to register this change.
5. Press and release the "SET/ENT" button twelve times to display "bS" and the current offset value.
6. Select the offset value with the arrow buttons that is needed to make this controller display correctly.  
For example, if the independent measurement is 553°C, the controller Temperature measurement display shows 550°C, and the current controller offset (bS) is -2, then make the controller display offset "+1"  
[(+3 needed offset) + (-2 current offset) = (+1 new offset)].
7. Press and release the "SET/ENT" button once to register this new offset value. Press and hold the "SET/ENT" button for 3 seconds to exit this controller menu.
8. Operate the controller to the same temperature to stabilize the chamber to check for any further variations between the controller and the independent measurement. Repeat steps 2 – 7 as necessary.
9. This completes the display offset procedure for the Yokogawa model UP150 temperature controller. If the button lockout parameter "LoC" was originally on a value of 1 or 2, repeat steps 3 & 4 to return to this original value.

Contact Technical Service at 1-800-438-4851 if you have any questions.

### 6.6 Changing Temperature Scale Between °C and °F

To change the temperature scale in the UP150 controller to operate on °F instead of the factory setting of °C, or from °F to °C, follow these steps.

These changes will alter the controller input type and associated scale-dependant parameters, **AND ERASE the stored program to default values**. Please document the stored program in the controller **BEFORE** proceeding.

If during this procedure the buttons are inactive for more than two minutes, the controller will return to the standard display.

1. Make sure the indicators beside "RUN" and "L" on the controller face are off. If they are on, press and hold the 'UP/RESET' button until the RUN or L indicators are off.
2. To access the Operating Parameters menu, press and HOLD the 'SET/ENT' button for at least 3 seconds to display "modE".
3. Press and release the 'SET/ENT' button until the display shows "LOC" in the upper display. Make sure the value below "LoC" is "0" (zero). If it is not "0" use 'down arrow' to make "0" and press and release "SET/ENT" button to register change to "0".
4. At "LoC" display, press the 'down arrow' to make the lower value "-1".
5. Press and release the "SET/ENT" button to enter the Setup Parameters menu and show "In" on the upper display and a numerical value in the lower display.
6. See table below for the STANDARD values for this parameter and the others needed in the following steps.
7. Select the appropriate value for the "In" parameter. Press the 'UP' or 'DOWN' arrow buttons to make the lower display to the new value, then press and release the 'SET/ENT' button TWICE to register the new value and advance to the next parameter.
8. "SPH" is the next parameter displayed. Select and enter the new value, then press and release the 'SET/ENT' button TWICE.
9. "SPL" is the next parameter displayed. Select and enter the new value, then press and release the 'SET/ENT' button ONCE.
10. Press and HOLD the 'SET/ENT' button for at least 3 seconds to exit.
11. Press and HOLD the 'SET/ENT' button for at least 3 seconds to enter the Operating Parameter menu and show "modE" in the upper display.
12. Press and release the 'SET/ENT' button until the upper display shows "P". Select the value in the table and adjust the lower display accordingly. Press and release the 'SET/ENT' button TWICE.
13. "I" is the next parameter displayed. Select and enter the new value, then press and release the 'SET/ENT' button TWICE.
14. "d" is the next parameter displayed. Select and enter the new value, then press and release the 'SET/ENT' button ONCE.
15. Press and HOLD the 'SET/ENT' button for at least 3 seconds to exit.
16. Reenter or create a program using the new temperature scale.

The following table shows the corresponding parameter values for 1100°C box furnaces in °C and °F:

Parameter	°C	°F
In	1	31
SPH	1100	2012
SPL	0	32
P	20	38
I	120	120
D	30	30

The P, I and D parameters may be altered through auto tuning (refer to Section 6.4 on page 14).

## 7 Communication Option

The Communication Option (available on models with a 'COM' suffix) enables digital communication between the UP150 controller and a PC. It is a factory-installed temperature controller and cable assembly using an RS-485 connection through a DB9 cable.

This option is supplied with the necessary cable and diagnostic software to set up and check the connections between the unit and the PC. Follow the steps below to make the cable connections and to check the data transfer. If you have purchased the 'SpecView Plus Communication Software' with the copy protection key, refer to the SpecView instructions in parallel with this setup outline.

### 7.1 Cable Installation

1. To install the 25-foot external cable, disconnect the electrical power from both the unit and PC.
2. Connect the cable end with a black housing to the 9-pin port on the rear of the Lindberg/Blue M unit.
3. Connect the other cable end with the RS-232/485 Converter to the COM 1 Port (or other COM port of your choice) on the rear of the PC.
4. If you have purchased the SpecView Plus Communication Software with the copy protection key, install this key on your parallel port. It may be necessary to locate the key between a cable and the parallel port.
5. Apply electrical power to the unit and the PC.

### 7.2 UP150 Communications Setup Parameters

Table 4 shows the default values for UP150 Communications Setup Parameters. To access these parameters:

1. Hold the **SET/ENT** button for three seconds to display the Operating Parameters. Press and release the **SET/ENT** button to display the 'LoC' parameter. Press the down arrow to show '-1' in the lower display and press **SET/ENT** to acknowledge and enter the Setup Parameters menu.
2. Press and release the **SET/ENT** button to access the six parameters specific to the communications option.

Table 4. UP150 Communications Parameters

Parameter Code	Factory Set Value	Description
<b>Communications Setup Parameters</b>		
PSL	0	Protocol selection
Adr	1	Controller address
bPs	9600	Baud rate
Pr 1	EVN	Parity (even)
StP	1	Stop bit
dLn	8	Data length

### 7.3 Software Installation

1. Load the SpecView software onto the PC hard drive, using the disks provided.
2. Run the software. (If you have purchased the SpecView Plus Communication Software with the copy protection key, skip step 3.)
3. If you do not have a copy protection key, a 'SpecView' window opens with the message, "Problem with Dongle: 'Dongle' (Copy Protection Key) not detected on parallel port." Click the OK button to acknowledge the message. Without the copy protection key, this diagnostic/sampler software has a 20-minute time limit on each run. If the message 'demo version of SpecView has stopped communicating - values are frozen' appears before the communication diagnostics are finished, close the software and reopen it for another 20-minute segment.
4. When the 'Configurations Found..' window opens, click on the "Test Comms for New Config." Button.
5. The 'Input Required..' window then opens. Enter a new Config. Name (up to 8 characters with no spaces) or accept the 'DEFAULT' name. Click OK.
6. The 'Ports and Protocol' window opens next. On the 'COM1:' line (if the COM1 port is the serial port used to connect to the controller) select the pulldown menu from Protocol column. Highlight "Yokogawa Green" for controller model UP150.
7. Select the pulldown menu from the Baud Rate column. Highlight "9600". Click on the 'Start Scan' button.
8. The SpecView program scans all 99 possible controller addresses and places a representative 'instrument view' of the temperature controller on the PC screen for each controller found connected to the PC. The factory-set addresses are 1, 2, 3, etc., depending on the number of controllers with communications in a single furnace. Additional units with communications will require the controller's address to be changed. See Section 7.8 on page 17 for detailed instructions on configuring multiple controllers.
9. After the instrument scan is completed, a SpecView window appears with the message, "All channels scanned. Press OK to continue, or cancel to rescan". Press OK if all of the connected controllers are properly displayed. If no controls are displayed, check the "troubleshooting" section at the end of this setup.
10. To begin communication between the PC and the controller, click on the 'Enter Runtime' button (an icon of a running figurine). This action will ask for a file name to save this display: use the given default or select another.
11. The "SpecView" window will be displayed, showing the current PV (process variable) and SP (set point). If the SpecView display of the controller shows X's, the communications connection or power to the control may have been interrupted.
12. On some controllers, the decimal point position has been changed from the Yokogawa factory default. This will make the SpecView display differ from the controller. If this is the case, follow the instructions in Section 7.7 on page 17.

#### 7.4 Communications Test

When you have established a working communications link between the controller and PC, you should check the link by varying the target set point function:

1. Click on the arrows of the controller(s) shown in the SpecView window. This will open a keypad window where the set point can be changed.
2. Select a temperature set point a few degrees from the current temperature and press the 'send' button. Verify that the controller display shows the setpoint change.
3. Select the original temperature set point through the keypad on the controller and observe the change on the PC display.
4. The controller parameters may be viewed through SpecView by clicking on the 'PAR' button. A window opens that lists the controller parameters. Each parameter can be changed by selecting it and clicking on the 'Alter' button. Select the 'Close' button. Make no changes at this time.

This concludes the initial software diagnostics.

#### 7.5 Ordering SpecView

If this software program is what you need as a tool to organize and operate the digital communication on Lindberg/Blue M equipment, contact Lindberg/Blue M sales, SpecView directly at sales@specview.com, or on their Internet site at www.specview.com, and request "SpecView Plus".

#### 7.6 Troubleshooting

If your connection is not working properly, check the following conditions:

- A. Verify complete and tight cable connections between the Lindberg/Blue M unit and the PC.
- B. Verify that power has been supplied to the unit and temperature controller before starting the software program.
- C. Verify the configuration values in the controller, listed in the Table 4 on page 16.
- D. Verify the values in the 'Ports & Protocols' window (see step 6 in Section 7.3).

#### 7.7 Decimal Point Adjustment

If the decimal point on the PC display of the controller does not match the controller display, you can make an adjustment to correct this:

1. From the Configuration Mode (available through the 'file' drop down while in the Runtime Mode), select the 'Variables List' icon, represented by a page with lines on it.
2. Select the controller model number and select 'Properties' button. The 'Add/Rename Instrument' box appears.
3. In the Address window, highlight the middle digit (usually a 1), and change to '0' (zero).
4. Click the 'Rename Only' button. Close the 'Variables' box (click on 'X' in corner of smaller box).
5. Select the 'Enter Runtime' icon to see the results of the change.

#### 7.8 Addresses for Multiple Controllers

When more than one controller has the same communication address, alternative addresses need to be set up in the individual controllers. Addresses 1 through 99 can be selected on the same communication link to each PC COM port.

1. Determine a unique address for each temperature controller equipped with the communications option.
2. On the UP150 controller, access the Operating Parameters menu by pressing and holding **SET/ENT** for 3 seconds.
3. Press and release **SET/ENT** repeatedly until the upper display reads LoC.
4. Press  $\nabla$  until the displayed value of LoC is -1; then press **SET/ENT** to access the Setup Parameters menu.
5. Press and release the **SET/ENT** button to access the six parameters specific to the communications option. Compare the displayed values to those in Table 4 on page 16. Make adjustments as needed.
6. Press and hold **SET/ENT** for 3 seconds to exit the Setup Parameters Menu.

## 8 Maintenance



**CAUTION!** Maintenance should only be performed by trained personnel.



**WARNING!** Disconnect furnace from main power before attempting any maintenance to furnace or its controls.



**WARNING!** Before maintaining this equipment, read the applicable MSDS (Material Safety Data Sheets) at the back of this manual.



**WARNING!** When installing, maintaining, or removing the refractory insulation, the following precautions will minimize airborne dust and ceramic fiber:

- Keep personnel not involved in maintenance out of the area.
- Use a good vacuum to clean area and equipment. Do **not** use compressed air.
- Use NIOSH high efficiency respirator (3M #8710 or equivalent).
- Wear long sleeve clothing, gloves, hat, and eye protection to minimize skin and eye contact. Do not wear contact lenses.
- Thoroughly wash self after work is complete.
- Launder work clothing separate from other clothes and thoroughly clean laundering equipment after use. If clothing contains a large amount of dust and/or ceramic fiber, dispose of rather than clean.
- Promptly place used ceramic fiber parts and dust in plastic bags and dispose of properly.

For replacement parts specifications, refer to Table 7 on page 23. For wiring schematics, refer to Section 10 on page 23.

### 8.1 Door Seal Adjustment

To adjust the door seal:

1. Door assemblies have hex nuts attaching the insulation frame to the outer door frame. Loosen the appropriate nuts and move the door insulation frame to improve the door seal.
2. Recheck the door seal, following the instructions in Section 5.2 on page 7.
3. If a gap is detected only in the center top edge of the door seal, then the top corners of the sealing surface of the door may be sanded to lessen the center gap.
4. After each adjustment recheck the door seal.

The door seal has been adjusted properly if there is no heat loss when operating the furnace up to 500°C.

### 8.2 Thermocouple Replacement



**WARNING!** Disconnect furnace from main power before attempting any maintenance to furnace or its controls.

**Note:** For optimal performance, the thermocouple should be replaced once a year. In some situations a more frequent replacement schedule is warranted. "b.o" on the controller display indicates a broken thermocouple.

Refer to Figure 7 as you perform the following procedure:

1. Remove any atmosphere piping connected to the atmosphere pipe (item #2 in Figure 7).
2. Remove the two screws from the atmosphere pipe. Pull the atmosphere pipe straight out of the furnace.



**CAUTION!** Failure to pull the atmosphere pipe straight out of the furnace will result in damage to the atmosphere pipe or the heating unit.

3. Remove the screws from rear panel corners. Remove the rear panel (item #1 in Figure 7).
4. Note polarity and wire location. Loosen the terminal screws and remove thermocouple lead wires.
5. Remove thermocouple mounting screws.
6. Slide out head and old thermocouple (item #3 in Figure 7).
7. Replace the thermocouple and connect new wires. Be careful not to bend the thermocouple wire. Red is always negative.
8. Replace the furnace rear panel.
9. Replace the atmosphere pipe.

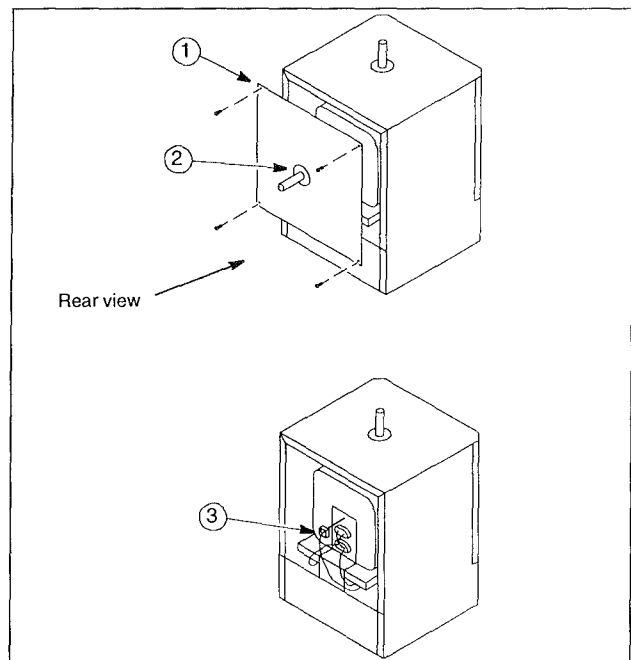

Figure 7. Thermocouple Replacement

### 8.3 Solid-State Relay Replacement



**WARNING!** Disconnect furnace from main power before attempting any maintenance to furnace or its controls.

Refer to the Troubleshooting section for relay testing. If the solid-state relay is inoperable, complete the following steps to replace the relay (refer to Figure 8):

1. Remove the screws located on the left and right sides of the control panel (item #1 in Figure 8).
2. Slide the panel assembly away from the unit to expose components.
3. Locate the solid-state relay on the component tray (item #2 in Figure 8).
4. Note the terminal connections of the relay wires and label them for reattachment. Remove the wires from the terminals of the relay.
5. Remove the mounting screws from the relay.
6. Replace the relay and reconnect the wires.
7. Reassemble the unit.

### 8.4 Power Relay Replacement



**WARNING!** Disconnect furnace from main power before attempting any maintenance to furnace or its controls.

Refer to the Troubleshooting section for power relay testing. If the power relay is inoperable, complete the following steps to replace the relay (refer to Figure 8):

1. Remove the screws located on the left and right sides of the control panel (item #1 in Figure 8).
2. Slide the panel assembly away from the unit to expose components.
3. Locate the power relay on the component tray (item #3 in Figure 8).
4. Note the terminal connections of the relay wires and label them for reattachment. Remove the wires from the terminals of the relay.
5. Remove the mounting screws from the relay.
6. Replace the relay and reconnect the wires.
7. Reassemble the unit.

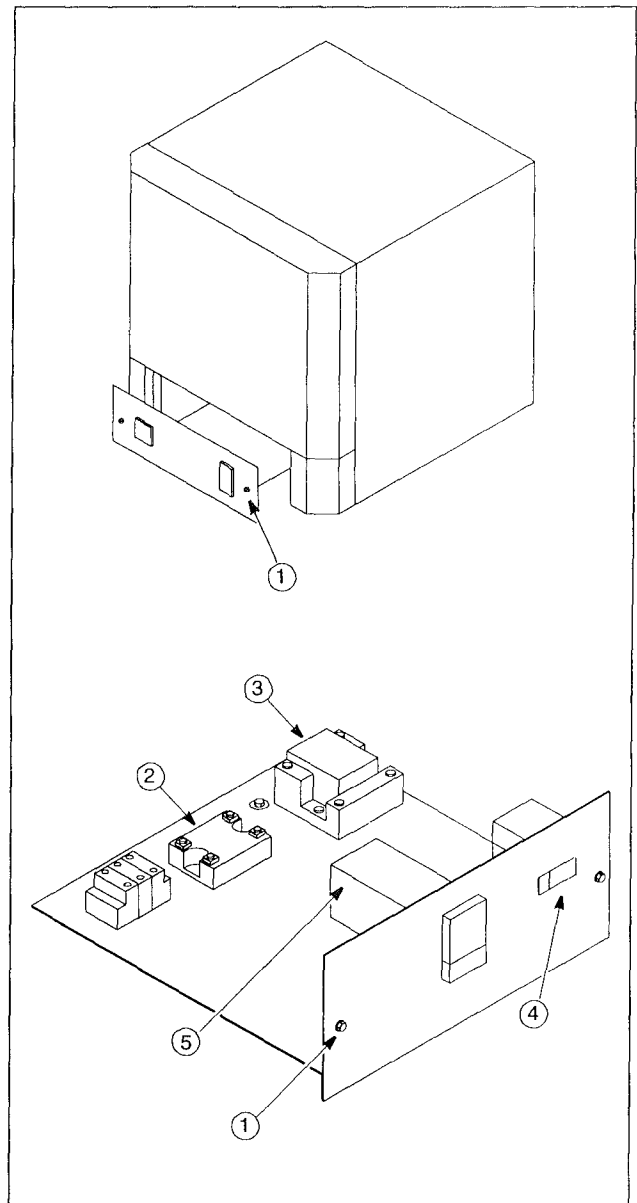

Figure 8. Solid State Relay Replacement

### 8.5 Temperature Controller Replacement



**WARNING!** Disconnect furnace from main power before attempting any maintenance to furnace or its controls.

To replace the entire controller, complete the following steps (refer to Figure 8):

1. Disconnect the main power and switch the circuit breaker (#4 in Figure 8) to the OFF position.
2. Remove the two sheet metal screws located on each side of the furnace near the lower front (#1 in Figure 8). Pull the control panel forward to access the controller (#5 in Figure 8).
3. Note the terminal connections of the wires and label them for reattachment. Remove power input and output wires from the back of the controller. Observe polarity for the thermocouple lead wire. Red is always negative. Refer to Figure 1 on page 3 for additional wiring information.
4. Remove the retaining clamp.
5. Pull the controller out through the front of the control panel.
6. Install the replacement instrument by reversing the above procedure.

### 8.6 Door Insulation Replacement



**WARNING!** When installing, maintaining, or removing the ceramic fiber insulation, the following precautions will minimize airborne dust and fiber:

- Keep personnel not involved in the installation out of the area.
- Use a good vacuum to clean area and equipment. Use a dust suppressant if sweeping is necessary. Do **not** use compressed air.
- Use a disposable mask suitable for nuisance dust.
- Wear long sleeve clothing, gloves, hat, and eye protection to minimize skin and eye contact. Do not wear contact lenses.
- Thoroughly wash self after work is complete.
- Launder work clothing separate from other clothes and thoroughly clean laundering equipment after use. If clothing contains a large amount of dust and/or fiber, dispose of rather than clean.
- Promptly place used ceramic fiber parts and dust in plastic bags and dispose of properly.

To replace the door insulation, complete the following steps (refer to Figure 9):

1. Open the door completely.
2. Loosen the hex nuts at the brackets.
3. Remove the brackets at the top and bottom.
4. Pull out the door insulation plug and frame.
5. Replace the insulation.
6. Install the new door insulation plug and frame.

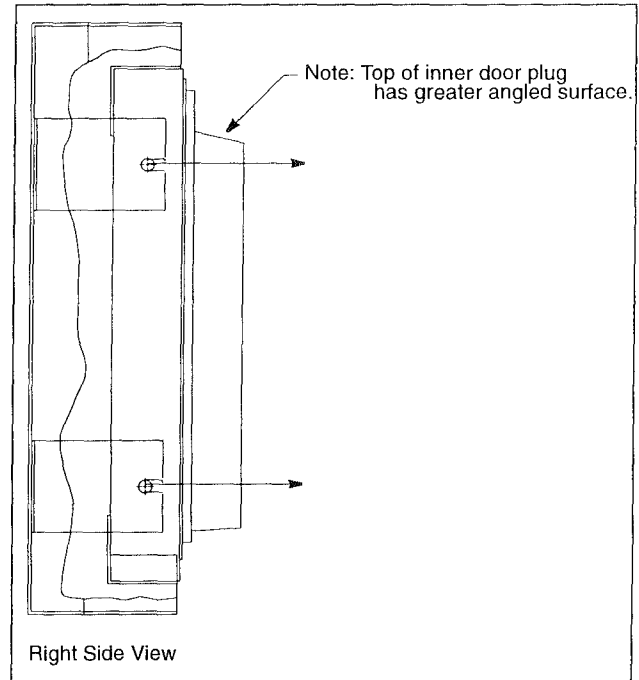

Figure 9. Door Insulation Replacement



### 8.7 Heating Unit Replacement



**WARNING!** Disconnect furnace from main power before attempting any maintenance to furnace or its controls.



**CAUTION!** This product contains ceramic fiber or other refractories which can result in the following:

- May be irritating to skin, eyes, and respiratory tract.
- May be harmful if inhaled.
- May contain or form cristobalite (crystalline silica) with use at high temperature (above 871°C) which can cause severe respiratory disease.
- Possible cancer hazard based on tests with laboratory animals. Animal studies to date are inconclusive. No human exposure studies with this product have been reported.

To replace the heating unit, complete the following steps (refer to Figure 10):

1. Remove any atmosphere piping connected to the atmosphere pipe (item #2 in Figure 10).
2. Remove the two screws from the atmosphere pipe. Pull the atmosphere pipe straight out of the furnace.



**CAUTION!** Failure to pull the atmosphere pipe straight out of the furnace will result in damage to the atmosphere pipe or the heating unit.

3. Remove the screws from corners of the rear panel (#1 in Figure 10).
4. Remove the rear panel to expose the heating unit assembly.
5. Remove the two screws from the exhaust vent. Pull the exhaust vent straight up and out of the furnace.
6. Remove the six corner screws from the shell (#3 in Figure 10).
7. Lift the shell away from the base of the cabinet to expose the entire heating unit.
8. Note the terminal connections of the element wires and label them for reattachment. Loosen the terminal nuts and remove the element wires (#4 in Figure 10).
9. Remove the thermocouple head screws and slide the thermocouple out (#5 in Figure 10).
10. Unhook the spring-bands from the base of the chassis.
11. Replace the heating unit.
12. Carefully make the necessary holes for exhaust and atmosphere ports and thermocouple with a hand-turned drill bit or a small cutting tool.
13. Reassemble the furnace.
14. Check and adjust the door seal, referring to Section 5.2 and Section 5.3.

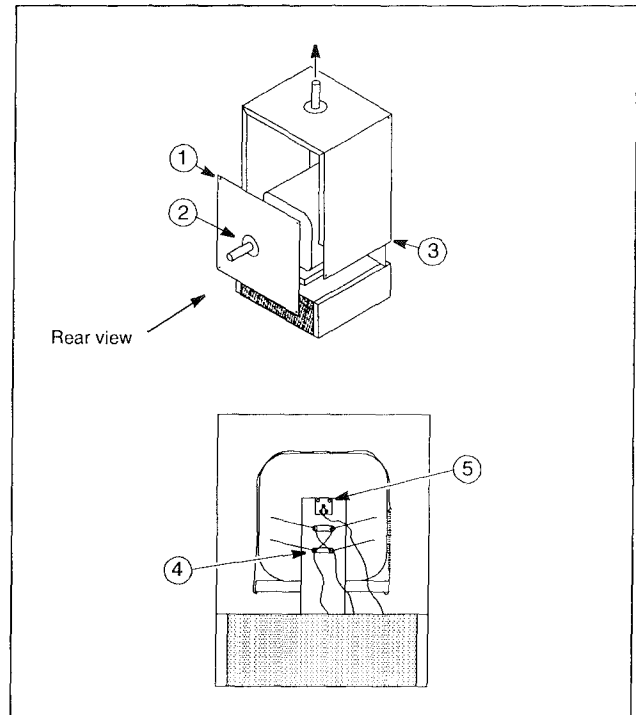

Figure 10. Heating Unit Replacement

## 9 Troubleshooting



**WARNING!** Troubleshooting procedures involve working with high voltages which can cause injury or death. Troubleshooting should only be performed by

trained personnel.

This section is a guide to troubleshooting controller and furnace problems.

**Table 5. UT150 Controller Troubleshooting**

Problem	Probable Causes	Solution
Controller reads P.Er.	Abnormal parameter value	Check controller parameter settings and reset to proper values.
Controller reads b. o	Input burnout	Check the sensor wiring, replace sensor if necessary.
Controller reads ooo.	PV exceeds effective range	Check the input type and range settings and correct them.
Controller reads UUU.	PV is below effective range	Check the input type and range settings and correct them.
Controller reads Err	Probable hardware failure	Call Service for controller repair.
The controller displays do not illuminate.	The furnace is not connected to the power supply.	Check furnace connection to power source.
	Main switch is defective.	Replace power switch or controller.
	Fuse(s) blown.	Replace fuse(s) and verify power connections.

**Table 6. Furnace Troubleshooting**

Problem	Solution
Furnace temperature runs away.	<p>Check solid-state relay:</p> <ol style="list-style-type: none"> <li>1. Remove the temperature controller from the furnace.</li> <li>2. Connect power to the furnace. If the heating unit heats, replace the solid-state relay.</li> </ol>
Furnace does not heat.	<p>Front panel red indicator light is on:</p> <ol style="list-style-type: none"> <li>1. If the controller output light is off, check that the setpoint temperature is higher than the furnace display temperature.</li> <li>2. If the controller output light is on, disconnect power from the furnace and check the heating elements for continuity.</li> </ol>
	<p>Front panel red indicator light is off:</p> <ol style="list-style-type: none"> <li>1. Check that the power switch is on.</li> <li>2. Check that the indicator lights on the controller display are on.</li> <li>3. Check that the furnace door is fully closed.</li> <li>4. Check that the door interrupt switch is engaged when the furnace door is fully closed.</li> <li>5. Check the electrical wires for visible damage. Replace the electrical wires if necessary.</li> <li>6. Check that the Alarm Setpoint on the controller is set higher than the operating temperature (refer to Section 5.5.1 on page 8).</li> </ol>

**10 Replacement Parts and Wiring Diagrams**

All quantities are one each unless noted.

**Table 7. Replacement Parts**

Furnace Model	BF51848*	BF51866*	BF51894	BF51828
Heating Unit	7011-2526-00A	7011-2629-00A	7011-2516-00A	301230H01
Thermocouple Head	7214-2051-00A	7214-2051-00A	7214-2051-00A	7214-2051-00A
Single Thermocouple	7299-1122-0BA	7299-1122-0BA	7299-1122-0BR	7299-1122-0BR
Hearth Plate	7011-2022-00B	7011-2022-00C	7011-2051-00A	7011-2066-00A
Solid-State Relay	102460	102460	102460	102460
Circuit Breaker	302795H05	302795H05	302795H05	302795H05
Thermocouple Leadwire	(4 ft) 33940-002	(6 ft) 33940-002	(7 ft) 33940-002	(8 ft) 33940-002
Door Insulation	7011-2523-00B	302025H01	7011-2513-00B	7011-2533-00B
Door Cutout Switch	76887H01	76887H01	76887H01	76887H01
Door Handle	16041	16041	16041	16041
Door Catch	16405	16405	16042	(2) 16042
Light, Red	33002-001	33002-001	33002-001	33002-001
Power Relay				
120V Model (A)	16869	16869	N/A	N/A
240V Model (C)	16934	16934	16934	16868
Temperature Controller	303115H19	303115H19	303115H19	303115H19
Cord Assembly				
120V Model (A)	48951H02	48951H02	N/A	N/A
240V Model (C)	48951H06	48951H06	48951H04	N/A

\* Voltage Code  
 A – 120V Model  
 C – 208/240V Model

The following pages contain the wiring schematics for the BF51800 series furnaces.

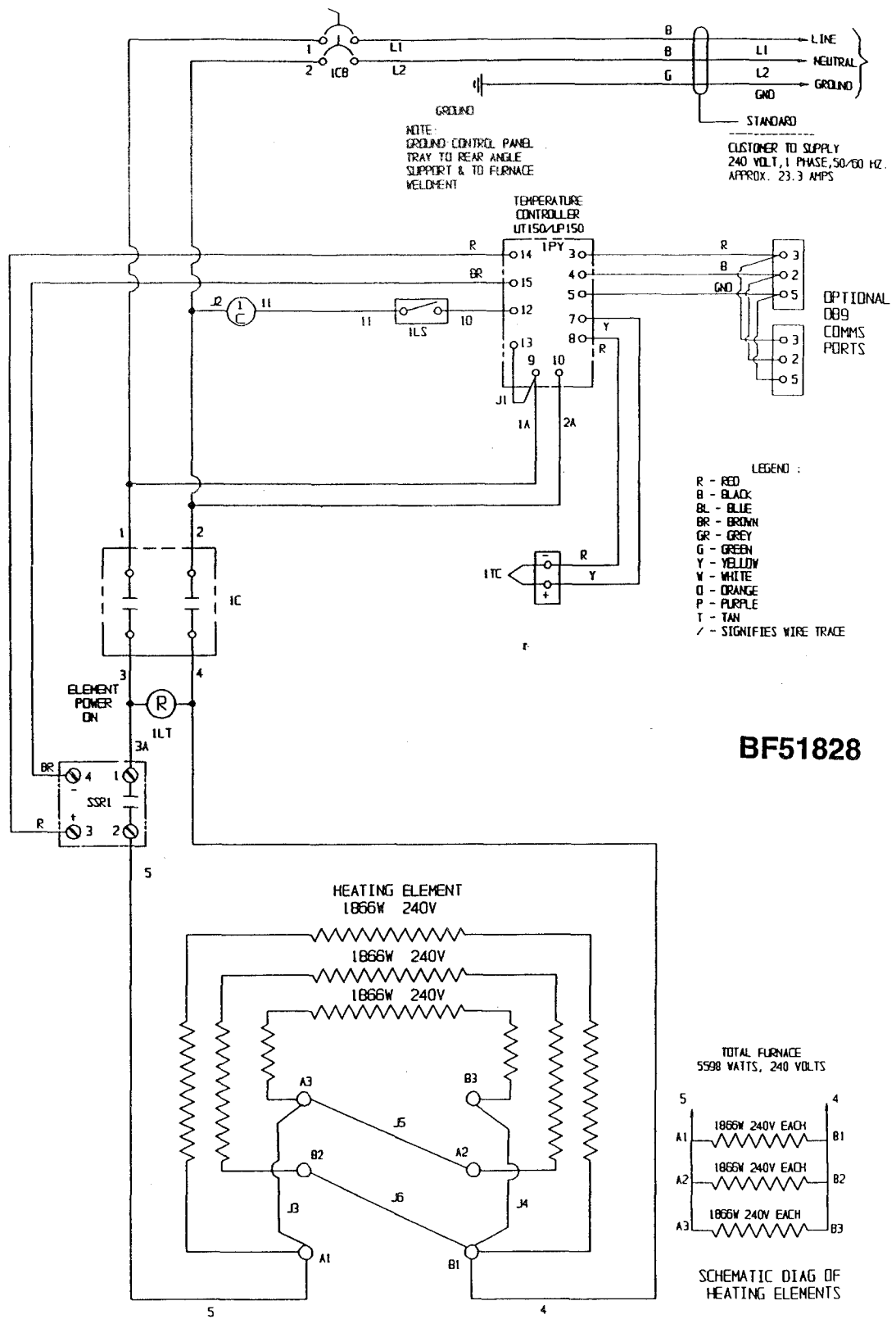

**BF51828**

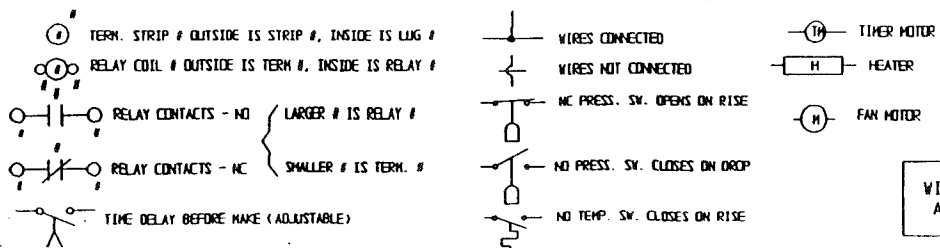

WIRING DIAGRAM  
A 304232 103



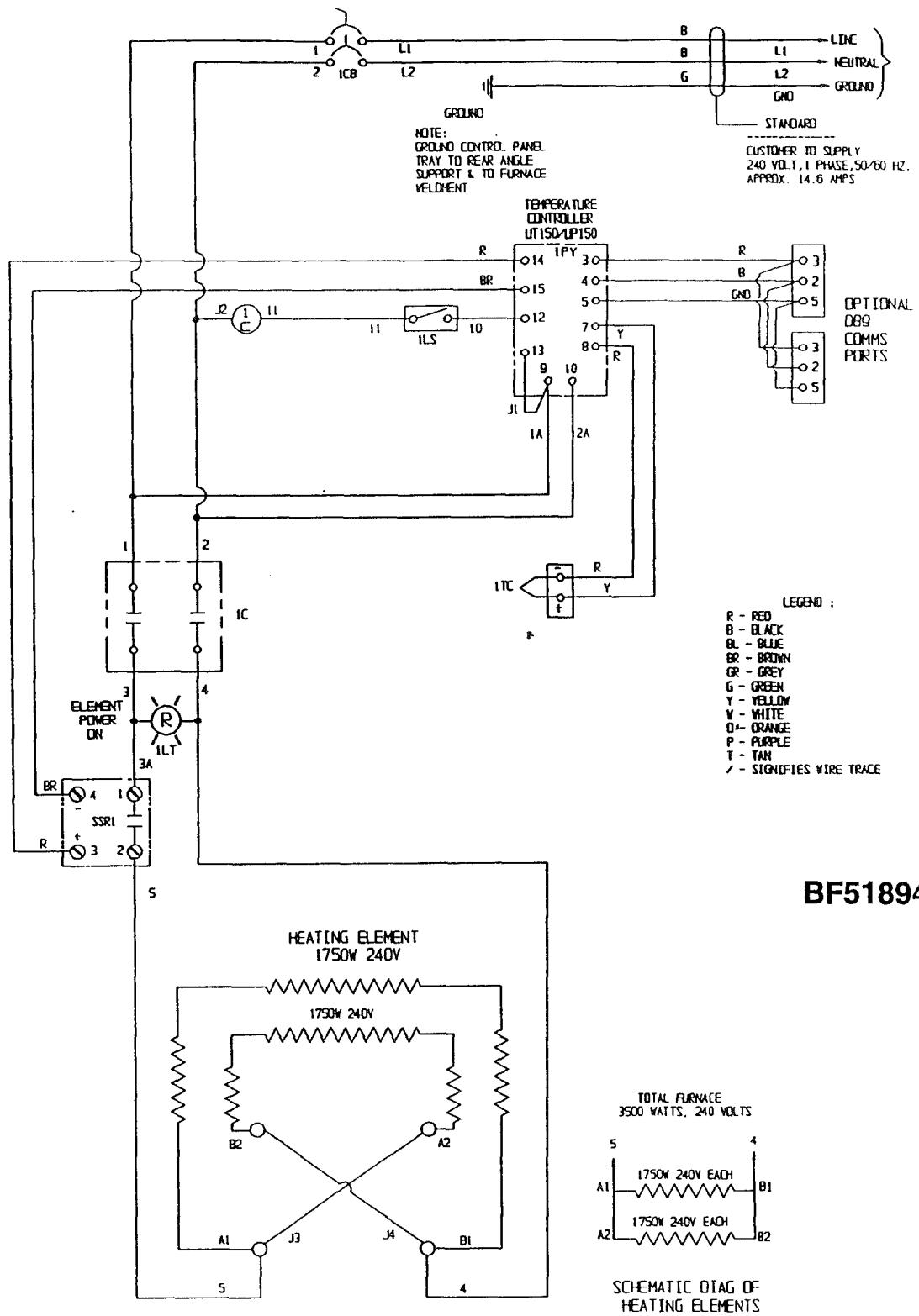

BF51894

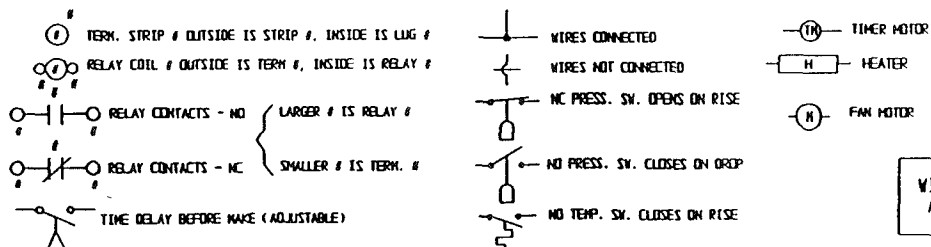

WIRING DIAGRAM  
A 304232 I02

## 11 Warranty

### 11.1 Domestic Warranty (United States and Canada)

Lindberg/Blue M warrants this product to the owner for a period of twelve (12) months from date of shipment by Lindberg/Blue M. Under this warranty Lindberg/Blue M through its authorized Dealer or service organizations, will repair or at its option replace any part found to contain a manufacturing defect in material or workmanship, without charge to the owner, for a period of ninety (90) days, the labor, and a period of one (1) year, the parts, necessary to remedy any such defect. All components used in the manufacture of this product are covered by this warranty excluding heating elements and thermocouples.

This warranty is limited to products purchased and installed in the United States and Canada. It does not apply to damage caused from failure to properly install, operate, or maintain the product in accordance with the printed instructions provided. This warranty shall not apply to equipment or parts which have been subjected to negligence, accident, or damage by circumstances beyond Lindberg/Blue M's control or improper operation, application, maintenance, or storage.

To obtain prompt warranty service, contact the nearest Lindberg/Blue M authorized service center or Dealer. A listing of these companies will be provided upon request. Lindberg/Blue M's own shipping records showing date of shipment shall be conclusive in establishing the warranty period.

This warranty is in lieu of any other warranties, expressed or implied, including merchantability or fitness for a particular purpose. The owner agrees that Lindberg/Blue M's sole liability with respect to defective parts shall be as set forth in this warranty, and any claims for incidental or consequential damages are expressly excluded.

### 11.2 International Warranty (excluding Canada) 12 Months Parts Warranty

Lindberg/Blue M warrants this product to the original owner for a period of twelve (12) months from the date of shipment from the Lindberg/Blue M factory. Thermocouples and heating elements are excluded from this warranty. If any part is found to contain a manufacturing defect in material or workmanship Lindberg/Blue M will, at its option, repair or replace the part. Lindberg/Blue M assumes no responsibility for any labor expenses for service, removal, or reinstallation required to repair or replace the part, or for incidental repairs, and such costs are the responsibility of the Owner and his Dealer.

The warranty does not apply to damage caused by accidents, misuse, fire, flood, Acts of God or any other events beyond Lindberg/Blue M's control or to damage caused from failure to properly install, operate, or maintain the product in accordance with the printed instructions provided by Lindberg/Blue M. To obtain prompt warranty service, simply contact the Dealer from whom you purchased the product or the nearest Dealer handling Lindberg/Blue M products. Lindberg/Blue M's own shipping records showing date of shipment shall be conclusive in establishing the warranty period.

This warranty is in lieu of any other warranties, expressed or implied, including merchantability or fitness for a particular purpose. The owner agrees that its sole remedy and Lindberg/Blue M's sole liability with respect to defective parts or any other claim shall be as set forth in this warranty, and any claims for incidental, consequential or other damages are expressly excluded.

For your future reference and when contacting the factory, please have the following information readily available:

Model Number: \_\_\_\_\_

Serial Number: \_\_\_\_\_

The above information can be found on the dataplate attached to the equipment. If available, please provide the date purchased, the source of purchase (Lindberg/Blue M or specific agent/rep organization), and purchase order number.

---

**IF YOU NEED ASSISTANCE:**

LINDBERG/BLUE M SALES DIVISION

Phone: 828/658-2711  
800/252-7100

FAX: 828/645-3368

LABORATORY PARTS and SERVICE

Phone: 828/658-2891  
800/438-4851

FAX: 828/658-2576

TECHNICAL SUPPORT

Phone: 800/438-4851

**LINDBERG/BLUE** 

275 Aiken Road  
Asheville, NC 28804  
U.S.A.



## 12 Moldatherm® Insulation Material Safety Data Sheet

Lindberg/Blue M, A Unit of General Signal

Moldatherm® Insulation Material Safety Data Sheet

**Manufacturer:** Lindberg/Blue M, A Unit of General Signal

**Address:** 275 Aiken Road  
Asheville NC 28804

**Telephone:** (704) 658-2711

**Revision Date:** November 6, 1992      **Replaces MSDS dated:** August 14, 1987

**Completed by:** Lindberg/Blue M Unit Environmental, Safety, and Health Department

I. PRODUCT IDENTIFICATION			
<b>Trade Name:</b>	Moldatherm II® Insulation (Also known as Moldatherm® Insulation)		
	Synonyms: Refractory Ceramic Fibers (RCFs); Ceramic Fiber; Man-Made Vitreous Fibers (MMVF); Mullite; High Alumina Ceramic Fiber		
<b>Chemical Family:</b>	Vitreous Aluminosilicate Fibers		
<b>Molecular Formula:</b>	Al <sub>2</sub> O <sub>3</sub> •SiO <sub>2</sub>		
II. PRODUCT COMPOSITION			
Component	CAS No.	Percent (%)	Exposure Limits (8 hr. TWA)
Aluminosilicate	NA – Mixture	79 to 99	1.0 fibers/cc**
Silica, amorphous	7631-86-9	1 to 21	10 mg/m <sup>3</sup> ACGIH/TLV 6 mg/m <sup>3</sup> OSHA/PEL
Remaining components not determined hazardous and/or other components present at less than 1.0% (0.1% for carcinogens).			
** NOTE: No OSHA or ACGIH exposure limits have been established for this material. The user is advised to follow the Lindberg/Blue M Recommended Exposure Limit (REL). (See Section VII. Personal Protective Equipment).			
Moldatherm® insulation will partially convert to cristobalite (CAS No. 14464-46-1), a form of crystalline silica, at operating temperatures at or above 1800°F. The rate and percentage of conversion to cristobalite is time and temperature dependent. (See Section X. Special Precautions/Supplemental Information.) Cristobalite has an OSHA permissible exposure limit (PEL) and ACGIH threshold limit value (TLV) of 0.05 mg/m <sup>3</sup> (respirable dust).			

NA = Not Applicable

III. PHYSICAL DATA			
Boiling Point:	NA	Vapor Pressure:	NA
Evaporation Rate:	NA	% Volatile:	NA
Melting Point:	Greater than 3000°F	Odor/Physical Description:	White, odorless solid
IV. FIRE AND EXPLOSION DATA			
Flash Point:	NA	Flammable Limits (LEL & UEL):	NA
Unusual Fire or Explosion Hazards:	None	Extinguishing Media:	NA
Fire Fighting Procedures:	Use extinguishing media suitable for surrounding fire.		
V. HEALTH HAZARDS			
<b>A. Health:</b>	WARNING! MAY BE IRRITATING TO SKIN, EYES, AND RESPIRATORY TRACT. MAY BE HARMFUL IF INHALED. POSSIBLE CANCER HAZARD BY INHALATION. Contains refractory ceramic fibers which MAY CAUSE CANCER BASED ON ANIMAL DATA. Risk of cancer depends on duration and level of exposure. (See Section X. for information concerning additional hazards after high temperature operation.)		
<b>B. Ingestion:</b>	Ingestion is unlikely. If ingested in sufficient quantity, may cause gastrointestinal disturbances. Symptoms may include irritation, nausea, vomiting, abdominal pain and diarrhea.		
<b>C. Skin:</b>	Slightly to moderate irritating. May cause irritation, inflammation, and rash.		
<b>D. Eye:</b>	Slightly to moderate irritating. Abrasive action may cause damage to the outer surface of the eye.		
<b>E. Inhalation:</b>	May irritate respiratory tract. Pre-existing medical conditions, especially chronic bronchial or lung disease may be aggravated by exposure.		
<b>F. Toxicity:</b>	Existing toxicology and epidemiology data are preliminary and the results presented below have not been validated by scientific review.		
<b>G. Epidemiology:</b>	<p>There are no known published reports of negative health affects of workers exposed to refractory ceramic fibers (RCFs). Studies of RCF production workers continues. Preliminary evidence, reportedly obtained from employees in RCF manufacturing facilities, indicates the following:</p> <ol style="list-style-type: none"> <li>1. There is no evidence on x-rays of any fibrotic lung disease of RCF manufacturing employees.</li> <li>2. There is no evidence of any lung disease among those employees exposed to RCF that never smoked.</li> <li>3. A statistical trend of slightly decreased pulmonary function was observed in the exposed population of workers based on the duration of RCF exposure. The statistic showing decreased pulmonary function was within the normal range and/or was insignificant.</li> </ol>		

NA = Not Applicable

	Pleural plaques (thickening along the chest wall) have been observed in a small number of employees who had a long duration of employment. There are several occupational and non-occupational causes for pleural plaque. Plaques are not “pre-cancer” nor are they associated with any measurable effect on lung function.
<b>H. Toxicology:</b>	<p>Several health effect studies of inhalation exposure of rats and hamsters are now reaching completion. In a lifetime nose-only inhalation study, rats exposed to a very high dose of 30 mg/m<sup>3</sup> (200 fibers/cc) developed progressive lung damage (interstitial fibrosis) and cancers of the lung and of the pleura (lining of the chest wall and lung). In contrast, hamsters similarly exposed developed interstitial fibrosis and pleural cancer, but no lung cancer. Cancer of the pleura is called mesothelioma.</p> <p>A multiple dose study (3, 9, 16 mg/m<sup>3</sup> or 25, 75, 150 fibers/cc, respectively) is currently ongoing in rats. After 24 months of exposure, only reversible cellular changes have been seen in the low dose group. At 9 mg/m<sup>3</sup> (75 fibers/cc), areas of lung fibrosis are barely discernible and at 16 mg/m<sup>3</sup> (150 fibers/cc) both lung and pleural fibrosis are present.</p> <p>At this time, no lung or pleural cancer has been seen in the multiple dose study. This information will be updated once the study is completed.</p> <p>In 1987, the International Agency for Research on Cancer (IARC) reviewed the carcinogenicity data on man-made vitreous fibers (including ceramic fiber, glasswool, rockwool, and slagwool). IARC classified ceramic fiber, fibrous glasswool and mineral wool (rockwool and slagwool) as possible human carcinogens (Group 2B).</p>
<b>VI. EMERGENCY AND FIRST AID PROCEDURES</b>	
<b>Ingestion:</b>	Drink extra water. Allow for natural gastrointestinal elimination. Get medical attention if gastrointestinal symptoms develop (see Section V.).
<b>Skin Contact:</b>	Remove contaminated clothing. Wash affected skin thoroughly with soap and water. Do not rub or scratch exposed skin. A skin cream or lotion used after washing may be helpful. Seek medical attention if irritation persists.
<b>Eye Contact:</b>	Immediately rinse eyes with water. Remove any contact lenses, and continue flushing eyes with running water for at least 15 minutes. Do not rub eyes. Hold eyelids apart to ensure rinsing of the entire surface of eyes and lids with water. Get immediate medical attention.
<b>Inhalation:</b>	Remove exposed person to fresh air. Seek medical attention if shortness of breath, cough, wheezing, or chest pain develop. If breathing is labored, administer oxygen until medical assistance can be rendered.
<b>VII. PERSONAL PROTECTIVE EQUIPMENT</b>	
<b>Eyes:</b>	Wear safety glasses or chemical goggles. Contact lenses should not be worn unless chemical goggles are also used and care is taken to not touch the eyes with contaminated body parts or materials.
<b>Skin:</b>	Wear gloves, hats and full body covering to prevent skin irritation as necessary (see Section X.).

NA = Not Applicable

<b>Respiratory Protection:</b>	<p>Use of properly designed and operating engineering controls is recommended and preferred over respiratory protection for controlling airborne dust and fiber concentrations.</p> <p>If exposures exceed our Recommended Exposure Limit (REL) of 1.0 fibers/cc of air (8 hour TWA) respiratory protection as outlined below must be used. Also, use respiratory protection if throat irritation is experienced. When airborne concentrations are unknown or exceed 0.5 f/cc, use of a half face respirator described below is recommended. Respiratory protection is necessary if the material has been exposed to temperatures at or above 1800°F. (See Section X.). Use only NIOSH/MSHA approved respirators.</p>
<b>Concentration (8 hour TWA)</b>	<b>Minimum Acceptable Respirator Type</b>
0 to 0.5 f/cc	Optional disposable dust respirator
0.5 f/cc to 5 f/cc or up to 10 times the OSHA PEL for cristobalite	Half face, air-purifying respirator equipped with high-efficiency particulate air (HEPA) filter cartridges
5 to 25 f/cc or up to 50 times the OSHA PEL for cristobalite (2.5 mg/m <sup>3</sup> )	Full face, air-purifying respirator with high-efficiency particulate air (HEPA) filter cartridges or powered air-purifying respirator (PAPR) equipped with HEPA filter cartridges
Greater than 25 f/cc or 50 times the OSHA PEL for cristobalite (2.5 mg/m <sup>3</sup> )	Full face, positive pressure supplied air respirator
As minimum protection, use half-mask air-purifying respirators equipped with HEPA filter cartridges if airborne fiber levels or cristobalite concentrations are not known.	
<p>PLEASE NOTE:</p> <p>Employees must be given instruction, fit testing, medical evaluation, and training per 29 CFR 1910.134 and your company's written respirator program if respiratory protection is used. Appropriate respirator selection must be a part of the respirator program. The above respirator recommendations are general guidelines only and may not be appropriate for certain applications. Please consult with your safety or industrial hygiene staff or consultants.</p>	
<b>VIII. REACTIVITY DATA</b>	
<b>Stability/Incompatibility:</b>	Stable under normal conditions of use. Soluble in hydrofluoric acid, phosphoric acid, and concentrated alkali.
<b>Hazardous Reactions/Decomposition Products:</b>	NONE
<b>IX. ENVIRONMENTAL AND REGULATORY INFORMATION</b>	
<b>Spill or Leak Procedure:</b>	Use vacuums equipped with HEPA filters to clean up spilled material. Wet sweeping is also acceptable.

NA = Not Applicable

<b>Waste Disposal:</b>	<p>This waste is not specifically listed as a hazardous waste under Federal regulations. However, it could be characteristically hazardous if it is considered toxic, corrosive, ignitable, or reactive according to Federal definitions (40 CFR 261). Additionally, it could be designated as hazardous or a special waste according to state regulations. This substance could also become a hazardous waste if it is mixed with or otherwise comes in contact with hazardous waste. Chemical additions, processing, or otherwise altering this material may make the waste management information presented in this MSDS incomplete, inaccurate, or otherwise inappropriate.</p> <p>The transportation, storage, treatment, and disposal of this waste material must be conducted in compliance with all applicable Federal, state, and local environmental regulations.</p>
<b>SARA Title III Information:</b>	<p>This material is designated a "delayed hazard" per the Superfund Amendments and Reauthorization Act (SARA) Section 311/312 (40 CFR 370).</p> <p>This product does not contain any toxic chemicals subject to the reporting requirements of SARA Section 313 (40 CFR 372).</p>
	<p>This product contains ceramic fibers which are on the State of California "Proposition 65" list (Safe Drinking Water and Toxic Enforcement Act of 1986).</p>
	<p>The Canadian Workplace Hazardous Materials Information System (WHMIS) category of "Other Toxic Effects" applies to this product.</p>
	<p>This product is not a DOT listed hazardous material. Use product name for bill of lading description.</p>
	<p>Some states have "special waste" regulations or other regulations which may apply to this product. Consult with your state environmental regulatory authorities.</p>
<b>X. SPECIAL PRECAUTIONS/SUPPLEMENTAL INFORMATION</b>	
<b>Handling/Storage:</b>	<p>Moldatherm® insulation should be handled with caution. Follow the personal protective equipment recommendations detailed in Section VII. Special precaution should be taken to avoid unnecessary cutting and tearing of the material to minimize generation of airborne dust.</p>
<b>Clothing:</b>	<p>Full body clothing is recommended to reduce the possibility of skin irritation. If possible, do not take unwashed work clothes home. Work clothes should be washed separately from other clothing. Rinse the washing machine thoroughly after laundering the work clothes. Inform your launderer of this cleaning procedure.</p>

NA = Not Applicable